



## SIMPLY CONSERVE

### 6 WATT GLOBE LED LAMP

Our 6 Watt Globe LED Lamp can replace incandescent bulbs while still maintaining decorative appeal. These bulbs have a wide variety of compatibility being able to be used in chandeliers, decorative fixtures, wall sconces and ceiling fan lighting.

#### THE FEATURES

- 25,000 hour average life
- 40 watt equivalent
- Dimmable
- 5 year warranty\*\*\*

#### THE PRODUCT SPECIFICATIONS

- **Input Line Voltage:**  
120VAC
- **Beam Angle:**  
240°
- **Lamp Life (rated):**  
25,000 Hours
- **Color Temperature:**  
2700K
- **Color Rendering Index:**  
82
- **U.L. / C.U.L. Listed:**  
Yes
- **FCC Certified:**  
Yes
- **Energy Star® Compliant:**  
Yes
- **RoHs Compliant:**  
Yes
- **ANSI Compliance:**  
Yes

MODEL #	WATTS	INCANDESCENT EQUIVALENT	INITIAL LUMENS	M.O.L.	DIAMETER	BASE	CASE QTY.
L06G2527K	6w	40w	450	4.78"	3.15"	E26	24
L06G2527KC60	6w	40w	450	4.78"	3.15"	E26	60

#### THE POTENTIAL ANNUAL SAVINGS\*

	6 WATT
DOLLAR SAVINGS	\$4
UTILITY SAVINGS	37 kWh

THE DIMENSIONS\*\*

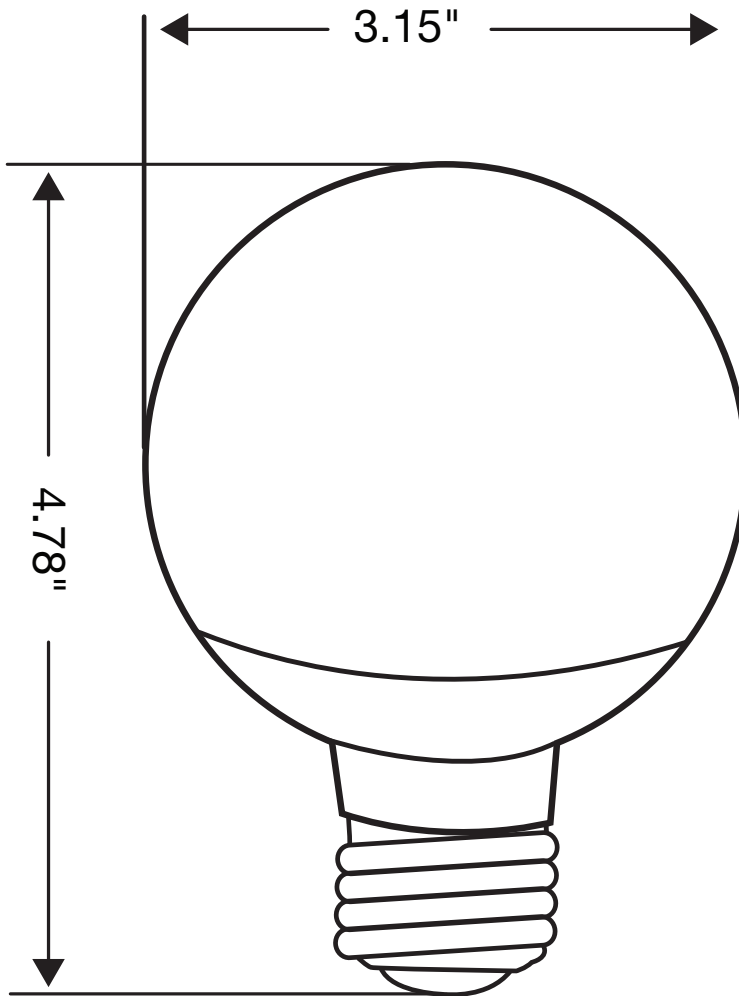

\*Factors in calculating savings potential:

3 hours a day of use (Energy Star Nov. 2013 Lightbulb Calculator — [http://www.energystar.gov/?c=cfls\\_pr\\_cfls\\_savings](http://www.energystar.gov/?c=cfls_pr_cfls_savings))

0.113¢ per kWh (Energy Star Nov. 2013 Lightbulb Calculator — [http://www.energystar.gov/?c=cfls\\_pr\\_cfls\\_savings](http://www.energystar.gov/?c=cfls_pr_cfls_savings))

\*\*Dimensions are subject to change

\*\*\*WARRANTY DETAILS

AM Conservation Group, Inc. guarantees to the original purchaser or recipient of this lamp that it is free from defects in material and workmanship for five years from the date of purchase. Warranty is limited to repair or replacement of the lamp. Lamps being returned must include proof of purchase.