

SIMPLY CONSERVE

13 WATT LED RECESSED RETROFIT DOWNLIGHT

Our dimmable 13 watt LED Recessed Retrofit Downlight uses up-to 82% less energy and designed to last 17.5 times longer than a traditional incandescent flood. This lamp is dimmable and compatible with most 120-volt incandescent, magnetic low-voltage, or electronic low-voltage dimmers.

THE FEATURES

- 35,000 hours of maintenance-free operation
- Suitable for damp locations
- Dimmable
- 75 watt equivalent
- Mercury and lead free
- 5 year warranty***

THE PRODUCT SPECIFICATIONS

- **Input Line Voltage:**
120VAC
- **Color Rendering Index:**
80
- **Input Line Frequency:**
60HZ
- **U.L. / C.U.L. Listed:**
Yes
- **Lamp Life (rated):**
35,000 Hours
- **Energy Star® Compliant:**
Yes
- **Color Temperature:**
3000K

MODEL #	WATTS	INCANDESCENT EQUIVALENT	INITIAL LUMENS	M.O.L.	DIAMETER	BASE	CASE QTY.
L13DL5/6-30K	13w	75w	900	3.03"	7.52"	E26	12

THE POTENTIAL LIFETIME SAVINGS*

	13 WATT
DOLLAR SAVINGS	\$239
UTILITY SAVINGS	2,170 kWh

THE DIMENSIONS**

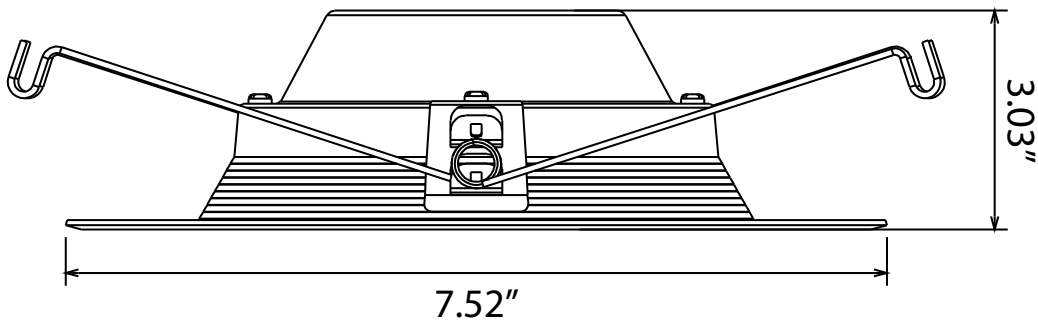

*Factors in calculating savings potential:

0.11¢ per kWh (<http://www.business.ftc.gov/documents/bus26-lighting-facts-questions-and-answers-manufacturers>)

**Dimensions are subject to change

***WARRANTY DETAILS

AM Conservation Group, Inc. guarantees to the original purchaser or recipient of this lamp that it is free from defects in material and workmanship for five years from the date of purchase. Warranty is limited to repair or replacement of the lamp. Lamps being returned must include proof of purchase.