



OWNER'S MANUAL DISHWASHER

Read this owner's manual thoroughly before operating the appliance and keep it handy for reference at all times.

SKSDW2402P



MFL71467501
Rev.04_061022

www.signaturekitchensuite.com

Copyright © 2020-2022 SIGNATURE KITCHEN SUITE. All Rights Reserved.

TABLE OF CONTENTS

3 PRODUCT FEATURES

4 SAFETY INSTRUCTIONS

4 IMPORTANT SAFETY INSTRUCTIONS

9 PRODUCT OVERVIEW

9 Exterior Parts

10 Interior Parts

10 Accessories

11 INSTALLATION

11 Installation Parts and Tools

12 Installation Overview

12 Product Dimensions

12 Product Specifications

13 Preparing Dishwasher

14 Installation Location Requirements

15 Installing Moisture Barrier Tape

15 Installing Fleece Tape

16 Preparing Water and Electrical Connections

17 Sliding Dishwasher into Cabinet Opening

19 Attaching Installation Brackets

19 Connecting Water Supply Line and Power

20 Connecting Drain Hose

22 Leveling Dishwasher

24 Securing Cabinet Panel to Dishwasher

25 Preparing Cabinet Panel

26 Mounting Cabinet Panel

26 Securing Dishwasher to Cabinet Opening

28 Final Installation Check

29 OPERATION

29 Using the Appliance

32 Control Panel

33 Cycles

34 Options

35 Auto Open Dry (AOD)

36 Cycle/Option Guide

37 Loading the Dishwasher

37 Loading the Lower Rack

39 Loading the Silverware Basket

40 Loading the Upper Rack

43 Loading the Cutlery Rack

45 Adding Cleaning Agents

47 SMART FUNCTIONS

47 The SIGNATURE KITCHEN SUITE
Application

50 Smart Diagnosis™ Feature

51 MAINTENANCE

51 Cleaning the Exterior

51 Cleaning the Interior

51 Seasonal Maintenance and Storage

52 Clogged Drain Air Gap or In-Sink Disposal

53 Cleaning the Filters

54 Cleaning the Spray Arms

55 TROUBLESHOOTING

55 FAQs: Frequently Asked Questions

58 Before Calling for Service

62 LIMITED WARRANTY

62 USA

64 CANADA

66 Warranty Exceptions (U.S. and Canada)

PRODUCT FEATURES

QuadWash™ System

Multi-Motion lower spray arm shoots water in various directions and at optimized intensities to reach every area of the tub. This system provides more powerful and complete cleaning coverage.

Inverter Direct Drive Motor

SIGNATURE KITCHEN SUITE experience in motor technology results in extraordinary functionality, with advanced features like the Dual Zone option, whisper-quiet operation, energy efficiency, and durability. The simple design and high build quality of the motor make it so reliable that it's covered for 10 years under the warranty.

EasyRack Plus

This easy-to-use system of adjustable tines and rack height provides more flexibility and versatility when loading dishes of various shapes and sizes.

Auto Open Dry System

The door opens automatically at the end of cycles that include drying in order to enhance the drying performance.

Signature Kitchen Suite Application

Download the smart phone app to set options, self-diagnose and troubleshoot problems with the appliance, and other useful features. This function uses Wi-Fi.

TrueSteam™ Technology

Tiny drops of purified water coat the surfaces of every dish from the steam that fills the tub, resulting in sparkling clean dishes.

Status Indicator Light

Status Indicator Light shows the status of the appliance: whether it has encountered any problems, whether it is operating normally, or whether it is ready to wash dishes.

TRUEFIT™ Sliding Panel

The appliance is panel ready, to allow for full integration with the surrounding cabinets. This appliance requires a custom front panel, which can be purchased from many cabinet manufacturers.

Remote Start

Use a smart phone to control the appliance remotely or check to see how much time is left in the cycle.

SAFETY INSTRUCTIONS

READ ALL INSTRUCTIONS BEFORE USE

Your safety and the safety of others are very important.

We have provided many important safety messages in this manual and on your appliance. Always read and follow all safety messages.



This is the safety alert symbol.

This symbol alerts you to potential hazards that can kill or injure you and others.

All safety messages will follow the safety alert symbol and either the word WARNING or CAUTION. These words mean:



WARNING

You may be killed or seriously injured if you do not follow instructions.



CAUTION

You may be slightly injured or cause damage to the product if you do not follow instructions.

All safety messages will tell you what the potential hazard is, tell you how to reduce the chance of injury, and tell you what may happen if the instructions are not followed.

IMPORTANT SAFETY INSTRUCTIONS



WARNING

To reduce the risk of explosion, fire, death, electric shock, scalding or injury to persons when using this product, follow basic precautions, including the following:

INSTALLATION

- Connect to a properly rated, protected, and sized power circuit to avoid electrical overload.
- To reduce the risk of severe injury or death, follow all installation instructions.
- The appliance must be installed and electrically grounded by qualified service personnel in accordance with local codes.
- Disconnect the power cord, house fuse or circuit breaker before installing or servicing the appliance.
- When moving or installing the product in a different location, call qualified service personnel for installation and service.
- Keep packing materials out of the reach of children. Packaging material can be dangerous for children. There is a risk of suffocation.
- Moving or installation of the appliance requires two or more people.

- This appliance is not designed for maritime use or for mobile installations such as in RVs, trailers, or aircraft.
- Store and install the appliance where it will not be exposed to temperatures below freezing or exposed to outdoor weather conditions.
- This appliance must be positioned near to an electrical power supply.
- Do not, under any circumstances, cut or remove the ground from the power cord.
- When installing or moving the appliance, be careful not to pinch, crush, or damage the power cord.
- Do not install the appliance in humid spaces.
- Destroy the carton, plastic bag, and other packing materials after the appliance is unpacked. Children might use them for play. Cartons covered with rugs, bedspreads, or plastic sheets can become airtight chambers.
- Never attempt to operate this appliance if it is damaged, malfunctioning, partially disassembled, or has missing or broken parts, including a damaged cord or plug.
- Adhere to all industry recommended safety procedures including the use of long sleeved gloves and safety glasses.
- The installer must ensure that the dishwasher is completely enclosed at the time of installation.
- Use new hoses when connecting the appliance to the water supply. Do not reuse old hoses.
- After installing, check the hose connection for leaks.
- Do not damage or place heavy items on the power cord of the appliance.

OPERATION

- Repair or immediately replace all power cords that have become frayed or otherwise damaged. Do not use a power cord that shows cracks or abrasion damage along its length or at either end.
- If you detect a strange sound, a chemical or burning smell, or smoke coming from the appliance, unplug it immediately, and contact an SIGNATURE KITCHEN SUITE customer information center.
- Never unplug the appliance by pulling on the power cord.
- Do not use an extension cable or adapter with this appliance.
- Do not grasp the power cord or touch the appliance controls with wet hands.
- Do not modify or extend the power cable.
- If the product has been submerged, contact an SIGNATURE KITCHEN SUITE customer information center for instructions before resuming use.
- Do not store or use gasoline or other flammable vapors and liquids in the vicinity of this or any other appliance.
- Keep the area underneath and around your appliances free of combustible materials (lint, paper, rags, etc.), gasoline, chemicals and other flammable vapors and liquids.
- This appliance is not intended for use by persons (including children) with reduced physical, sensory or mental capabilities, or lack of experience and knowledge, unless they have been given supervision or instruction concerning the use of the appliance by a person responsible for their safety.
- If the electrical supply line is damaged, it must only be replaced by the manufacturer or its service agent or a similar qualified person in order to avoid a hazard.
- Do not abuse, sit on, or stand on the door of the appliance.
- Read all instructions before using the appliance and save these instructions.
- Use this appliance only for its intended purpose.

- Do not allow children to play on, in or with the appliance. Close supervision of children is necessary when the appliance is used near children.
- Do not tamper with controls.
- In the event of a gas leak (propane gas, LP gas, etc.) do not operate this or any other appliance. Open a window or door to ventilate the area immediately.
- Under certain conditions, hydrogen gas may be produced in a hot-water system that has not been used for two weeks or more. **HYDROGEN GAS IS EXPLOSIVE.** If the hot-water system has not been used for such a period, before using the appliance turn on all hot water faucets and let the water flow from each for several minutes. This will release any accumulated hydrogen gas. As the gas is flammable, do not smoke or use an open flame during this time.
- Fix the drain hose securely in place.
- Use only detergents or wetting agents recommended for use in a dishwasher and keep them out of the reach of children.
- Do not let children eat detergent or dishwasher rinse agent.
- When loading items to be washed:
 - Locate sharp items so that they are not likely to damage the door seal.
 - Load sharp knives with the handles up to reduce the risk of cut-type injuries.
- Do not wash plastic items unless they are marked “dishwasher safe” or the equivalent. For plastic items not so marked, check the manufacturer’s recommendations.
- Do not touch the HEATING ELEMENT during or immediately after use.
- Do not operate your dishwasher unless all ENCLOSURE panels are properly in place.
- Do not abuse, sit on, or stand on the door or dish rack of the dishwasher.
- Do not install or store the dishwasher where it will be exposed to weather conditions.
- After cleaning the dishes, turn off the faucet. Turn on the faucet again and check the connection status of water supply hose before cleaning.
- Do not open the door while operating. For safety reasons, the drain pump operates if the door is opened, resulting in a longer cycle time.
- Be careful not to catch your hand when closing the door of the product.
- Do not plug the dishwasher into a damaged outlet.
- Do not install or keep the dishwasher near electrical components or exposed flames.
- Do not wash dishes exposed to gasoline, solvents or other flammable materials.
- When cleaning, do not spray water on the product directly.
- Do not press buttons with a sharp object such as an awl or pin.
- Do not use solvent-based detergent.
- Do not come into contact with the steam outlet.
- Small parts, such as rack clips and filter retaining posts can be a choke hazard to small children if removed from the dishwasher. Keep out of reach of small children.

MAINTENANCE

- Do not repair or replace any part of the appliance. All repairs and servicing must be performed by qualified service personnel unless specifically recommended in this Owner's Manual. Use only authorized factory parts.
- Do not disassemble or repair the appliance by yourself.
- Remove any dust or foreign matter from the power cord.
- Disconnect this appliance from the power supply before cleaning and attempting any user maintenance. Turning the controls to the OFF position does not disconnect this appliance from the power supply.
- Remove the door before the appliance is removed from service or discarded to avoid the danger of children or small animals getting trapped inside.
- Unplug the appliance before cleaning to avoid the risk of electric shock.
- Before discarding the appliance, cut off the power cord and destroy the appliance's control panel.

GROUNDING INSTRUCTIONS

- This appliance must be grounded. In the event of a malfunction or breakdown, grounding will reduce the risk of electric shock by providing a path of least resistance for electric current.
- This appliance is equipped with a cord having an equipment-grounding conductor and a grounding plug.
- The plug must be plugged into an appropriate outlet that is installed and grounded in accordance with all local codes and ordinances.



WARNING

Improper connection of the equipment-grounding conductor can result in a risk of electric shock. Check with a qualified electrician or service representative if you are in doubt whether the appliance is properly grounded. Do not modify the plug provided with the appliance, if it will not fit the outlet, have a proper outlet installed by a qualified electrician.

TIP OVER HAZARD

- Do not use the dishwasher until completely installed.
- Do not push down on the open dishwasher door.
- Failure to follow these instructions may result in serious injury or cuts.

SAVE THESE INSTRUCTIONS

 **CAUTION**

To reduce the risk of minor injury to persons, malfunction, or damage to the product or property when using this product, follow basic precautions, including the following:

INSTALLATION

- Install the product on a firm and level floor.
- This dishwasher must be connected to a hot water supply with a temperature range between 120 °F (49 °C) and 149 °F (65 °C). This temperature range provides the best washing results and shortest cycle time. The temperature should not exceed 149°F (65 °C) to prevent damage to dishes.
- Do not put the drain hose under the dishwasher during installation.
- Use caution when opening or closing the appliance door before installing the custom panel. The door may open or close abruptly.

OPERATION

- Do not place objects on top of the appliance.
- Turn off the water faucets and unplug the appliance if the appliance is to be left for an extended period of time, such as during vacations.
- Do not store or spill liquid detergents, cleaners, or bleaches (chlorine bleach, oxygen bleach) on the appliance. Doing so may result in corrosion, discoloration or damage to the surface of the appliance.
- Do not touch draining water which may be hot.
- If the drain hose and the water supply hose are frozen in winter, defrost before using the appliance.
- Do not put hands, feet, or metal objects below or behind the appliance.
- Do not put the drain hose under the dishwasher during installation.

MAINTENANCE

- If cooking oil is spilled on the exterior of the product, wipe it off immediately. Do not clean the exterior of the product with cleaners which contain alcohol, thinners, bleach, benzene, flammable liquids, or abrasives. These substances may discolor or damage the appliance.

PRODUCT OVERVIEW

Exterior Parts

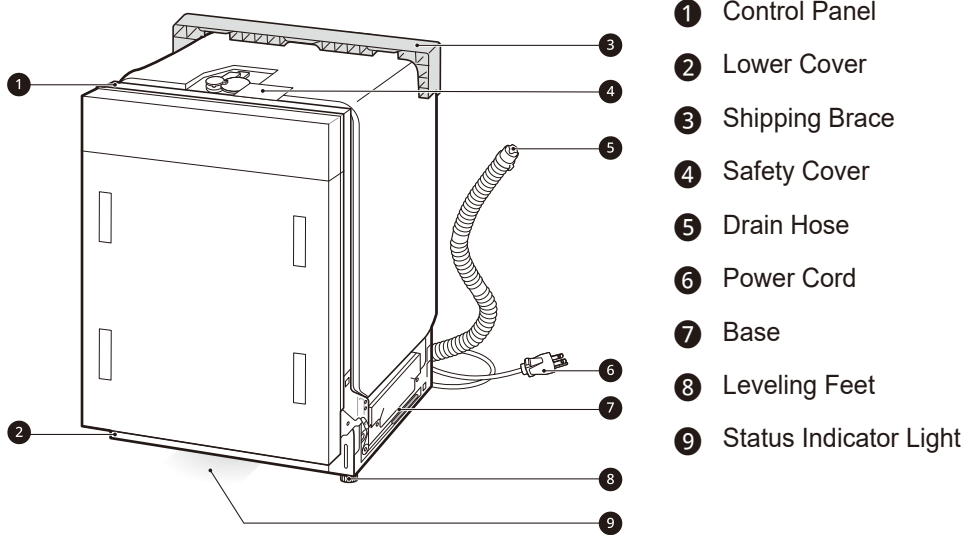

NOTE

- Do not remove the safety cover at any time.
- To ensure reliability, each Signature Kitchen Suite dishwasher goes through thorough quality control before it leaves the factory.
- You may find water droplets or water spots from this process inside your new dishwasher.

Status Indicator Light

The Status Indicator light at the bottom of the dishwasher shows the status of the appliance: whether it has encountered any problems, whether it is operating normally, or whether it is ready to wash dishes.

White LED

- Pulses when the cycle is running
- Remains on when the cycle is finished.
- Turns off when the door is opened.

Red LED

- Flashes if the appliance encounters an error. For more information about error codes, see the Troubleshooting section.

Interior Parts

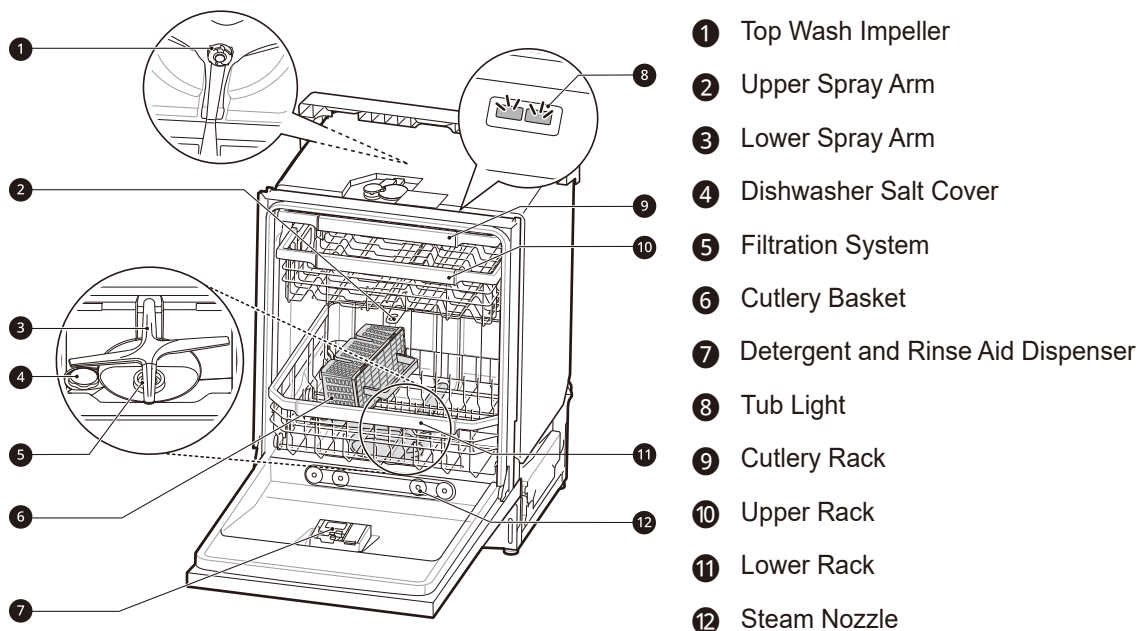

NOTE

- The cutlery basket ships installed at the back of the bottom rack. For best performance, install it along the right side.
- Remove all packing materials from the exterior and interior of the dishwasher before installing the appliance.

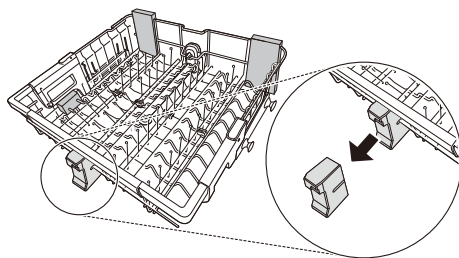

Accessories

Included Accessories

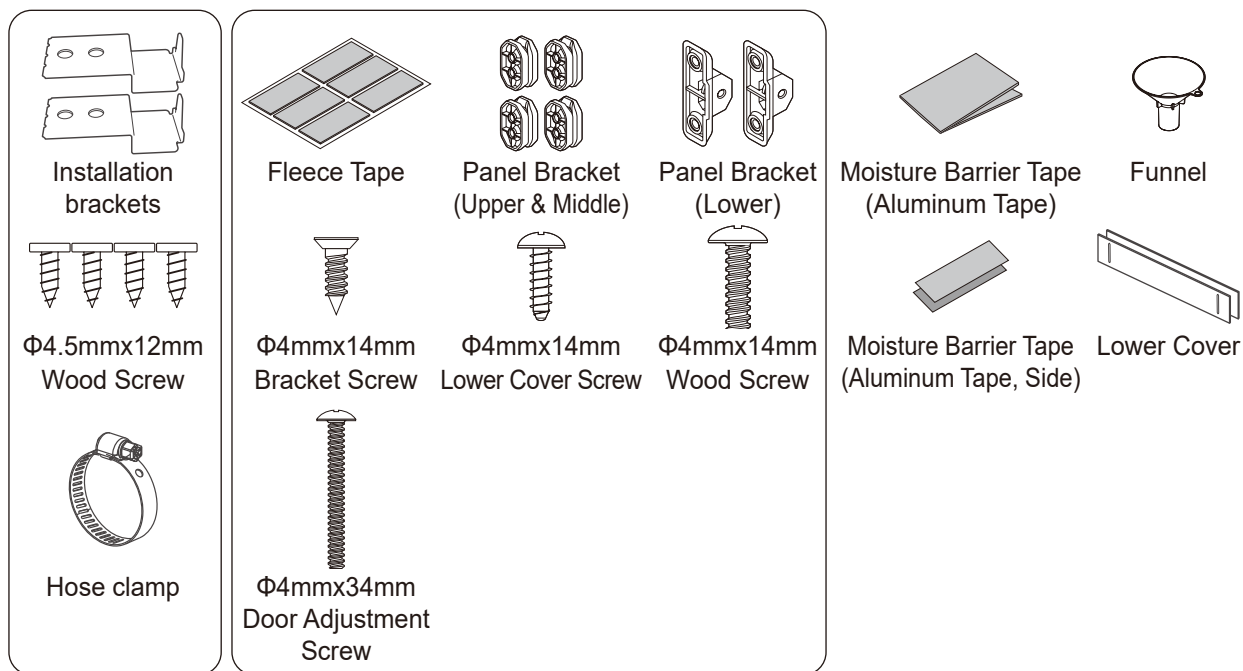

INSTALLATION

Installation Parts and Tools

Parts not Provided

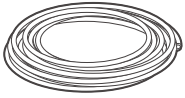

Water supply tube



Fittings for tube

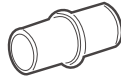

Coupler



Air gap



Hose clamp



3/4" Elbow

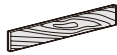

Baseboard (Wood)



Wood Panel & Handle

Tools Needed

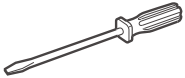

Flat-blade screwdriver



Phillips screwdriver



Hole saw min. 2 1/2" bit



Electrical drill



Gloves



Safety glasses

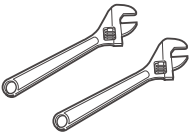

Adjustable wrench (2)

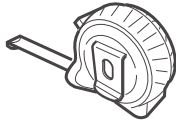

Tape measure

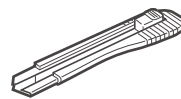

Utility knife

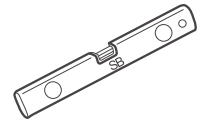

Level

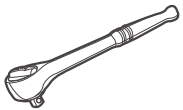

1/4" Square drive wrench



Pliers



Scale



Tape

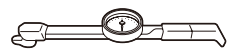

Torque wrench

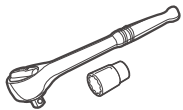

3/8" Square drive wrench + 1/2" Socket

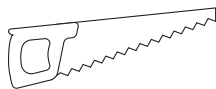

Saw

Installation Overview

- | | |
|--|--|
| Preparing Dishwasher | Connecting Water Supply Line and Power |
| Installation Location Requirements | Leveling Dishwasher |
| Installing Moisture Barrier Tape | Securing Cabinet Panel to Dishwasher |
| Installing Fleece Tape | Preparing Cabinet Panel |
| Preparing Water and Electrical Connections | Mounting Cabinet Panel |
| Sliding Dishwasher into Cabinet Opening | Securing Dishwasher to Cabinet Opening |
| Attaching Installation Brackets | Final Installation Check |

Product Dimensions

Product

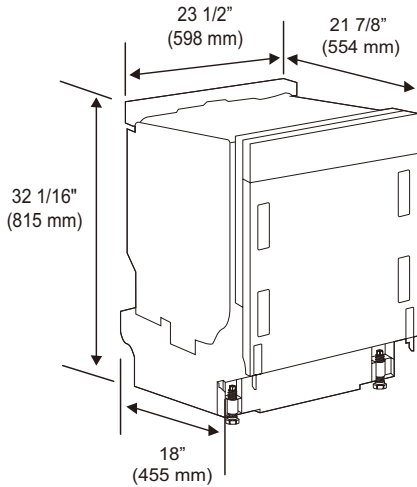

Cabinet Panel

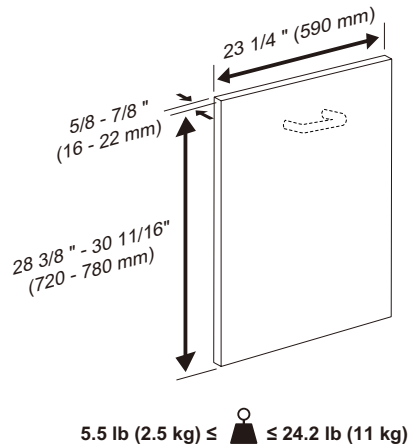

Product Specifications

The appearance and specifications listed in this manual may vary due to constant product improvements.

Electrical requirement	120 V, 60 Hz AC only, minimum 15 A circuit breaker
Water pressure	20 - 80 psi (140 - 550 kPa)
Dimensions (W X D X H)	23 1/2" X 21 7/8" X 32 1/16" 598 mm X 554 mm X 815 mm
Inlet water temperature	120 °F (49 °C) minimum, 149 °F (65 °C) maximum
Net weight	88 lb (40 kg)

Preparing Dishwasher

WARNING

- Do not remove safety cover **1**. Removal can result in fire, electric shock or death.

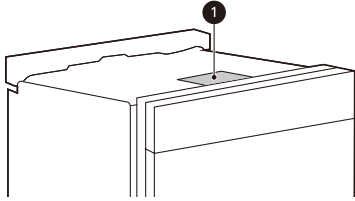

Releasing Drain Hose

Remove the twist tie holding the drain hose to the back of the shipping brace.

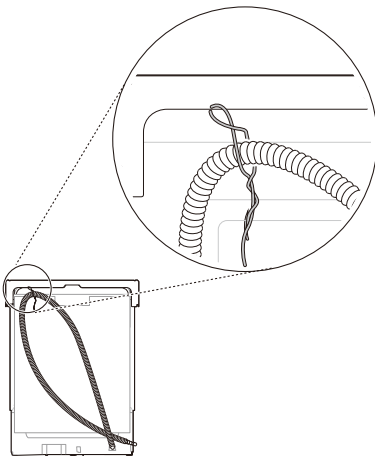

Removable Shipping Brace

The rear shipping brace can be removed if additional clearance is needed when installing the dishwasher under a low countertop.

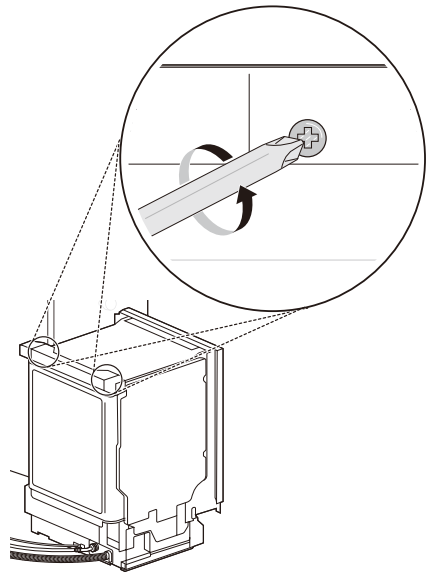

Removing Packing Materials from the Interior

Remove all packing materials from the interior of the dishwasher before installing the appliance.

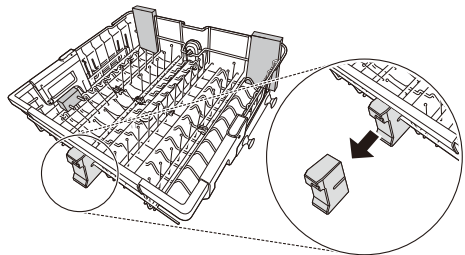

CAUTION

- Take care when opening or closing the appliance door before the custom door panel is installed. The door may open or close abruptly without the weight of the panel.

Installation Location Requirements

Preparing Cabinet Opening

This dishwasher is designed to fit a standard dishwasher opening. An opening may be needed on sides to route plumbing and electrical connections.

- To ensure proper drainage, install the dishwasher no more than 12 ft. (3.65 m) from the sink.
- The location must have sufficient space for the dishwasher door to open easily and provide at least 0.1" (2 mm) between the dishwasher and the cabinet sides.
- If installing the dishwasher in a corner, leave a minimum of 2" (50 mm) between the dishwasher and the adjacent wall.
- The adjacent wall must be free of obstructions.
- For flush installations only, you may remove the cabinet brace ① inside the cabinet.

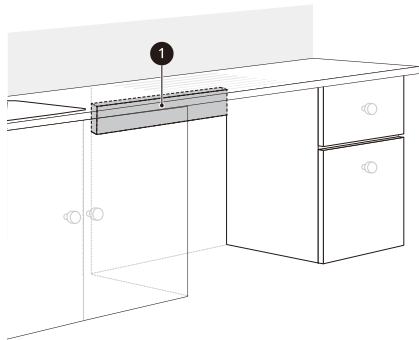

- 1 Select a location as close to the sink as possible for easy connections to water supply line, drain hose and electrical connection.

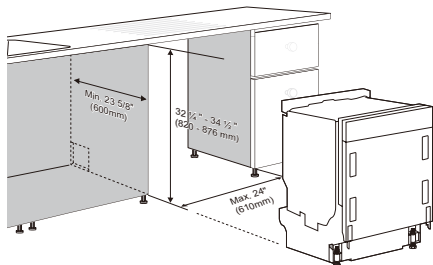

- 2 Check that all surfaces have no protrusions, lips or other trim that would prohibit dishwasher installation.

- 3 To allow for proper clearance of plumbing and electrical, use the template included with the literature to determine the clearance on the side of the cabinet where the cabinet meets the back wall. Using a 2 1/2" diameter hole saw, drill a hole in the target area as shown on the template.

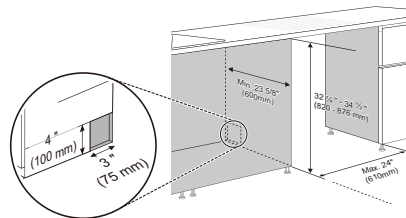

⚠ WARNING

- Installation damage is not covered by the warranty, and leaks caused by improper installation may result in property damage.
- Do not use existing holes unless they are in the target area.
- Failure to properly locate the hole for the water and drain lines may prevent the dishwasher from installing flush with the cabinets and could result in kinked, pinched, crushed, stressed or damaged lines.

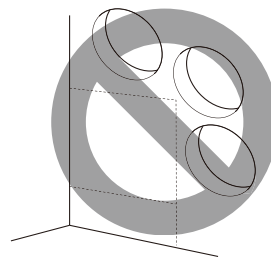

Checking the Cabinet Panel

This dishwasher is designed to work with a cabinet front panel (not provided) which slides up as the door is opened. Before installing the dishwasher, check the weight and dimensions of the cabinet front panel you have selected.

- The dishwasher can support panels weighing 5.5–24.2 lb (2.5–11 kg).

- If the cabinet panel weighs between 17.6 lb (8 kg) and 24.2 lb (11 kg), adjust the door spring tension to make the door easier to open. See the **Adjusting Door Spring Tension** section.

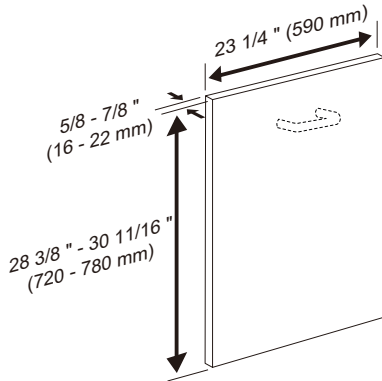

5.5 lb (2.5 kg) ≤  ≤ 24.2 lb (11 kg)

You can adjust the width dimensions of the wood panel to match the cabinet width.

Installing Moisture Barrier Tape

Install the moisture barrier tape to the underside of the countertop to protect the surface from condensation when the appliance is opened.

- 1 Clean and dry the area on the underside of the countertop and the sides of the cabinet opening where the tape will be applied.

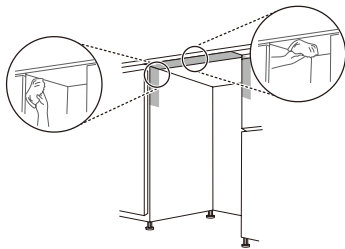

- 2 Remove the protective film from the tape.



- 3 Install the tape on the underside of the countertop.

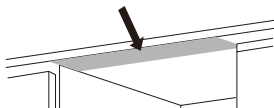

- 4 Install the shorter pieces of tape to the sides of the cabinet opening at the top.

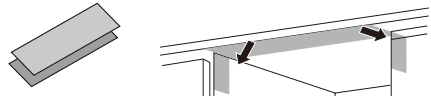

NOTE

- Moisture barrier tape is included in the manual assembly bag.
- If the countertop is made of granite or a waterproof material, the moisture barrier tape is not required.
- Condensation may occur on the underside or along the front edge of the countertop when the room temperature is low.

Installing Fleece Tape

Attaching fleece tape between the dishwasher door and the cabinet panel will reduce the friction when the door slides up and down.

- 1 Install the fleece tape close to the bracket openings to make sure the door slides smoothly.
- 2 Peel the fleece tape strips off the carrier and attach them to the door.

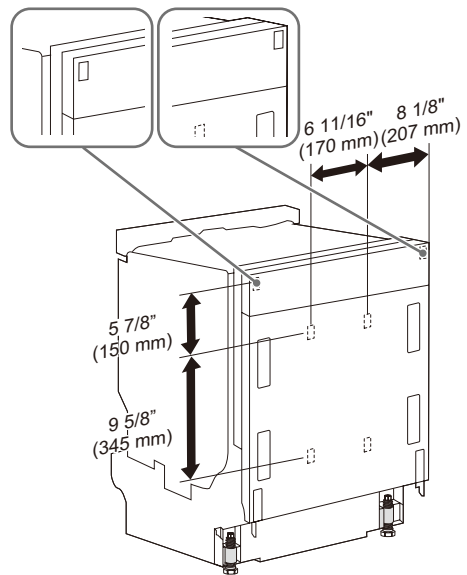

Preparing Water and Electrical Connections

Connecting Water Supply Tube and Power

*Water supply tube: Minimum 3/8" O.D. copper tubing or metal braided dishwasher supply line

- 1 Connect the elbow ① to the inlet valve on the back of the dishwasher.

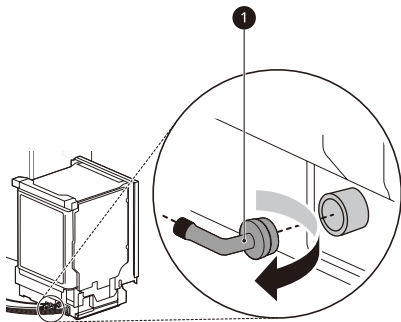

- 2 Connect the water supply tube to the elbow.

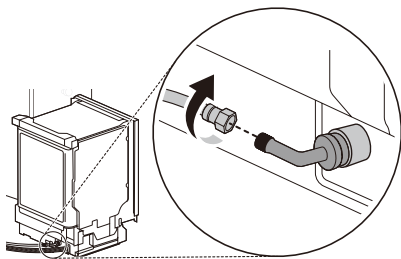

- 3 Tighten both connections using two adjustable wrenches to avoid putting stress on the water inlet valve.

- 4 Make sure the water supply is turned off. Connect the water supply tube to the tap.

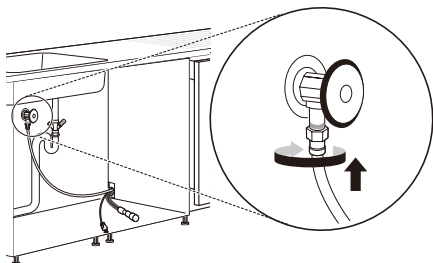

- 5 Insert the power plug into an outlet.

- 6 Turn on the water and check for leaks at the connections.
 - If there is a leak, reconnect the elbow.
 - Do not cross thread or overtighten the connections to avoid leakage.

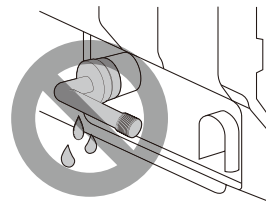

- 7 Unplug the power cord.
- 8 Turn off the water supply and disconnect the water supply tube at the tap.

! WARNING

Water Connection

- Do not reuse an old hose. Use only a new hose when installing the dishwasher. The old hose could leak or burst causing flooding and property damage. Contact a SIGNATURE KITCHEN SUITE Customer Information Center for assistance in buying a new hose.

Electrical Connection

- Use a time-delay fuse or circuit breaker.
- Operate this appliance with the correct voltage as shown in this manual and on the rating plate.
- The wiring must be grounded properly. If in doubt, have it checked by a qualified electrician.
- The appliance and outlet must be positioned so that the plug is easily accessible.
- Do not use an extension cable or adapter with this dishwasher.
- Do not overload the outlet with more than one appliance.
- It is the personal responsibility and obligation of the product owner to have a proper outlet installed by a qualified electrician.

⚠ CAUTION

- When connecting the dishwasher water supply line to the house water supply, sealing tape or compound should be used on pipe threads to avoid leaks. Tape or compound should not be used on compression fittings.
- Connect the dishwasher to a hot water supply with a temperature range between 120 °F (49 °C) and 149 °F (65 °C). This temperature range provides the best washing results and shortest cycle time. To prevent damage to dishes, the temperature should not exceed 149 °F (65 °C).
- Water supply pressure must be between 20 psi and 80 psi (140–550 kPa). If the water supply pressure exceeds 80 psi, a pressure reducing valve must be installed. Otherwise premature failure of the inlet valve may occur.

Sliding Dishwasher into Cabinet Opening**⚠ CAUTION**

- Do not pull or lift the dishwasher using the door ①. Doing so can damage the door and hinges.

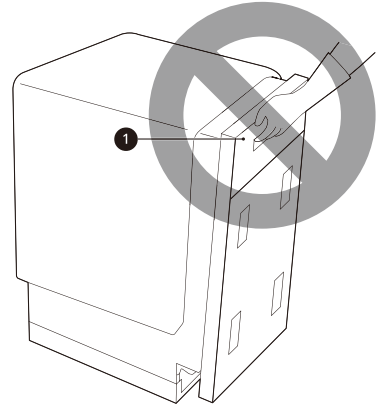

- Do not push the door of the dishwasher with knees when sliding the dishwasher into position. Doing so can damage the front cover.

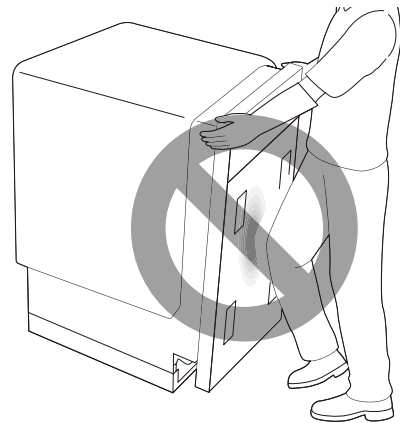

- Do not push the top of the dishwasher. Doing so can damage the interior of the dishwasher.

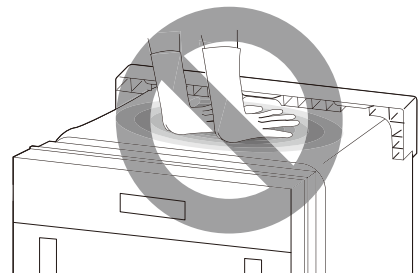

NOTE

- Open the door and grab the body frame and the top front opening ② of the tub to move or lift the dishwasher.

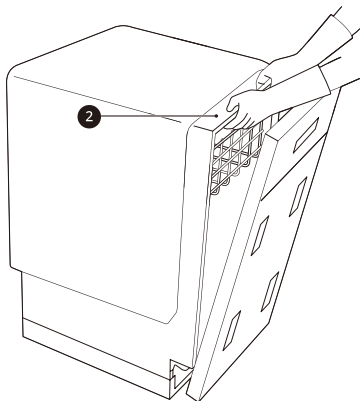

- 1 Align the dishwasher with the opening. Make sure the water supply line and power cord extend smoothly without kinks or bends.

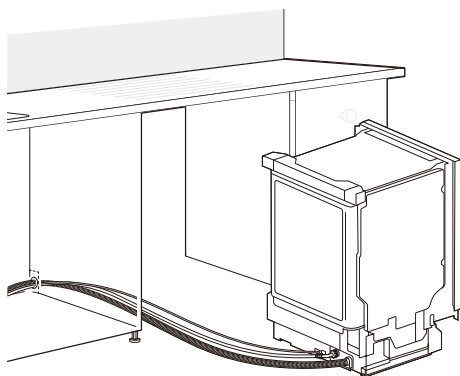

- 2 Smooth out or pad the edges of the hole drilled for the water supply to avoid damaging the drain hose.

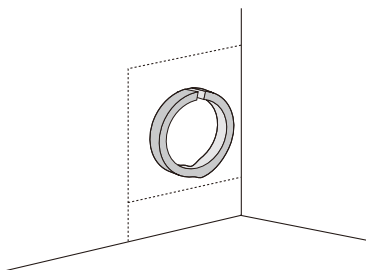

- 3 Make sure the drain hose is straight before feeding the end of it through the hole for the water supply. As you slide the dishwasher into the opening, slowly pull on the drain hose from inside the cabinet to take up some slack. Be careful not to kink, pinch, crush or stress the drain hose during installation to avoid leaking and water damage.

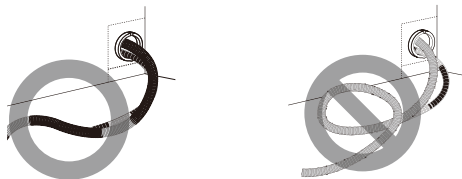

- 4 Gradually slide the dishwasher into the opening, making sure that the water supply line and power cord are passing freely through the opening and do not get caught under the dishwasher.
 - As you slide the dishwasher into the opening, stop periodically (or have an assistant help) to take up the slack by pulling the drain hose farther into the cabinet.

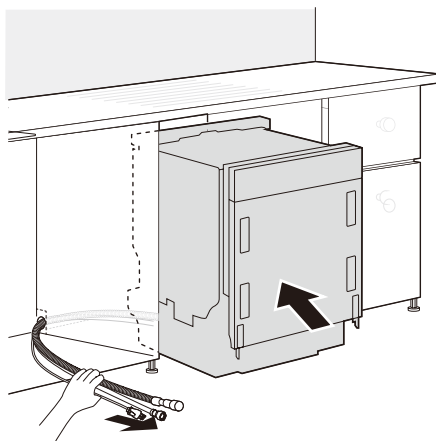
**⚠ CAUTION**

- To avoid malfunctions or leakage, it is important that the drain hose not get kinked, pinched, stressed or crushed behind or under the dishwasher or inside the neighboring cabinet.
- Damage resulting from improper installation is not covered under the warranty.

Attaching Installation Brackets

For countertops made of wood or other material that will not be damaged by drilling, use the metal installation brackets provided.

For countertops made of granite, marble, or other materials that could be damaged by drilling, use the wood screws to attach the dishwasher to the cabinet. See installation instructions in **Securing Dishwasher to Cabinet Opening**.

NOTE

- Installation brackets and screws can be found in the silverware basket.

- 1 Insert the tabbed end of the installation brackets into the slots in the upper frame. Rotate the brackets until the tabbed ends are facing up.

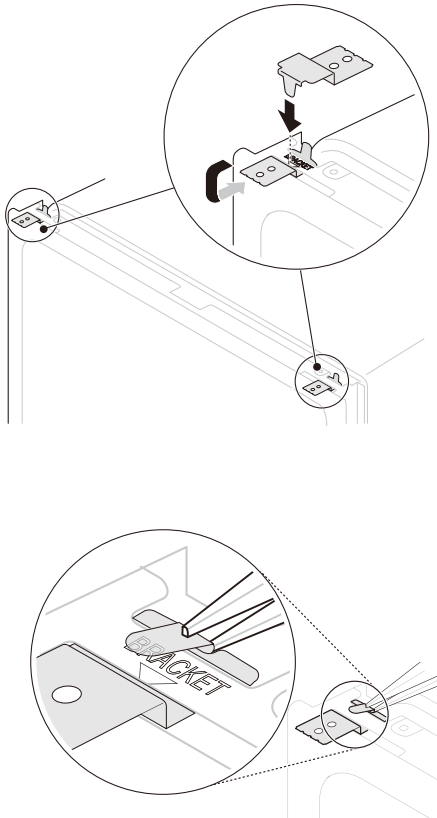

Connecting Water Supply Line and Power

Connecting Water Supply Line

- 1 With the home water supply turned off, connect the water supply tube to the tap.

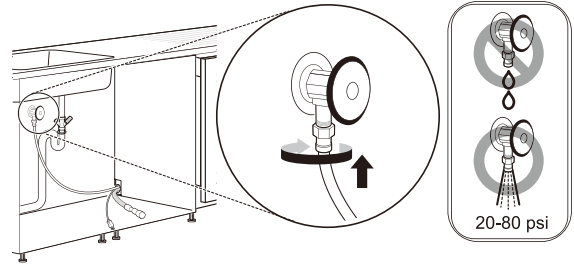

- 2 Tighten the connection using a square drive wrench to avoid putting stress on the water tap.

Connecting Power

Insert the power plug into a grounded outlet.

- The power cord should not be positioned behind the appliance but within 47.2 inches of the side so that the plug is easily accessible.

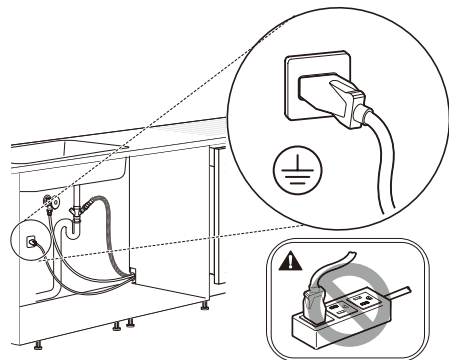

⚠ WARNING

- Do not use an extension cord or 2-prong adapter.

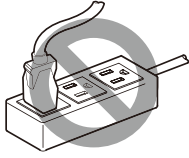

- The plug must be plugged into an appropriate outlet that is properly installed and grounded in accordance with all local codes and ordinances.
- Connect to a properly rated, protected, and sized power circuit to avoid electrical overload.

Connecting Drain Hose

If the end of the drain hose does not fit the drain line, use a heat and detergent resistant adapter (not supplied). These may be obtained from a local plumbing supply store.

- Cut the adapter so the end matches the size of the drain connection.

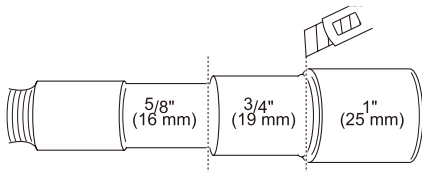
**NOTE**

- For drain hose installation, use the screw style hose clamp provided with this dishwasher in the silverware basket.
- If connecting the dishwasher's drain hose to the garbage disposal, be sure to follow your garbage disposal's manual for proper installation instructions.

Drain Hose Requirements

- Follow local codes and ordinances.
- Do not exceed 12 ft. (3.65 m) distance to drain.
- Do not connect drain hoses from other appliances to the dishwasher's drain hose.
- If an extension drain hose is required, use a 5/8" or 7/8" inside diameter, 2-3 ft. length hose and a coupler **1** for connecting the two hose ends.

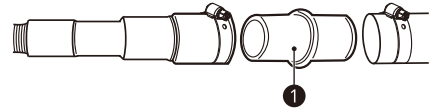
**Connecting to Disposal without Air Gap**

The height of the drain hose end must be at least 12" (305 mm) and within 40" (1016 mm) from the base of the dishwasher to avoid water being siphoned from the tub.

- Remove the knockout plug **1** on the disposal with a hammer and screwdriver.

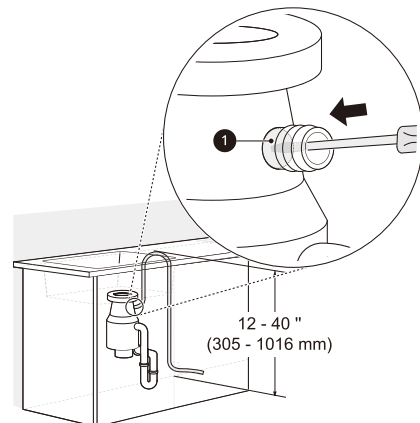

- 2 Remove the knockout plug ❶ from the disposal.

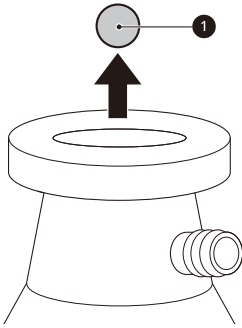

CAUTION

- If the knockout plug has not been removed, the dishwasher will not be able to drain properly.

- 3 Attach the drain hose to the disposal with the hose clamp provided. Move the hose clamp into position and tighten it with a flat-blade screwdriver.

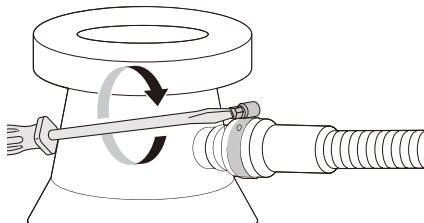

Connecting Waste Tee without Air Gap

The height of the drain hose end must be at least 12" (305 mm) and within 40" (1016 mm) from the base of the dishwasher to avoid water being siphoned from the tub.

- 1 Remove the knockout plug with a hammer and screwdriver.

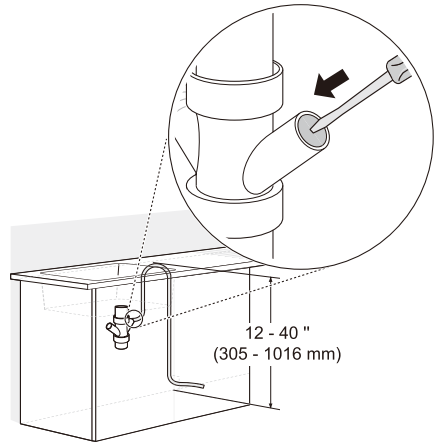

CAUTION

- If the knockout plug has not been removed, the dishwasher will not be able to drain properly.

- 2 Attach the drain hose to the waste tee with the hose clamp provided. Move the clamp into position and tighten it with a flat-blade screwdriver.

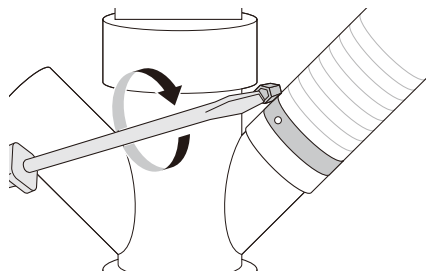

Connecting to Disposal or Waste Tee with Air Gap

- 1 Remove the knockout plug with a hammer and screwdriver.
- 2 Connect the end of the drain hose ① to the air gap ② with the hose clamp provided. Move the clamp into position and tighten it with a flat-blade screwdriver.
 - This avoids water being siphoned from the tub.

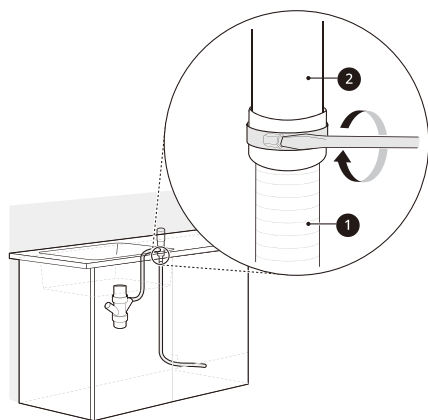

- 3 If it is not connected, attach the rubber hose connector to the disposal or waste tee with a hose clamp (not provided).

Leveling Dishwasher

Check that the dishwasher is level and adjust the leveling feet if necessary.

⚠ CAUTION

- Failure to level the dishwasher may result in leakage, problems closing the door, or noise.
- Where the cabinet opening is narrower than recommended (see **Preparing Cabinet Opening**), the dishwasher must be carefully leveled and aligned so that the dishwasher is supported fully by the 3 leveling feet and is not hanging from the installation brackets. Failure to do so can result in leaks from the front of the dishwasher, AE errors, difficulty in closing the door, or failure to operate.

Checking Leveling

To check that the tub is level from front to back, remove the lower rack and pour 135 oz. (4L) of water into the bottom of the tub. The water level should be near the center of both tub lower indentations at the front.

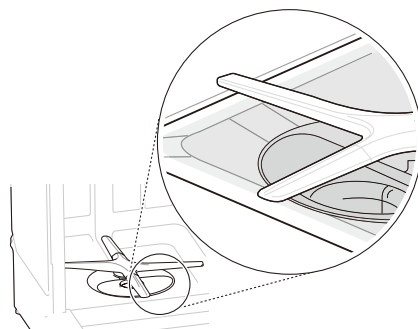

With the lower rack removed, place a level on the inside wall of the tub to check that the dishwasher is level from side to side.

- If you do not have a level, try using a smartphone level application instead.

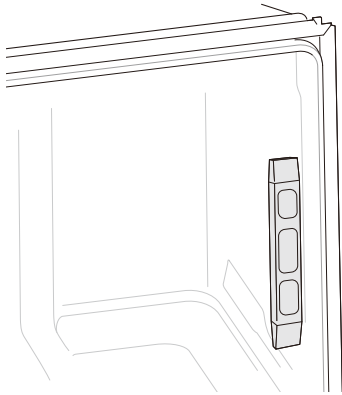

Make sure that the gap between the tub walls and the door liner is the same on either side.

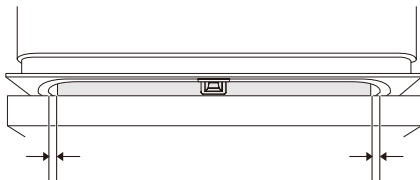

Adjusting Leveling Feet

Adjust as needed until the dishwasher is completely leveled.

Adjusting Front Leveling Feet

- Use a flat-blade screwdriver to turn the front leveling feet and adjust the front of the tub.
- Turn the front leveling feet clockwise to raise the front of the tub and counterclockwise to lower it.
- The adjustments work identically for both front leveling feet.

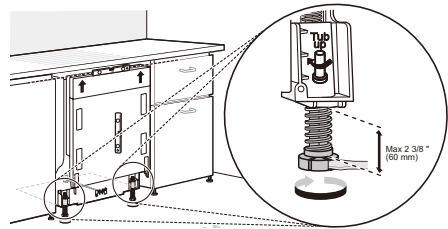

If a flat-blade screwdriver is unavailable, use a 1/4" square drive wrench (1) or 3/8" square drive wrench (2) with 1/2" socket (3) to turn the front leveling feet and adjust the front of the tub.

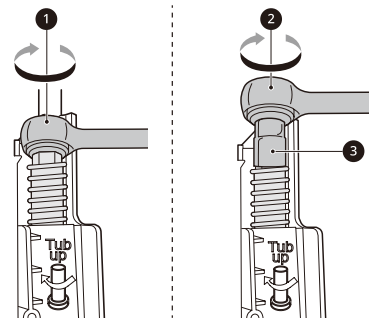

Adjust the front and rear leveling legs until they are all in firm contact with the floor. Failure to level the dishwasher may prevent the door from closing properly and the dishwasher will not turn on.

Adjusting Rear Leveling Foot

- Use a Phillips screwdriver to adjust the rear leveling foot and the rear of the tub using the center screw at the base of the appliance in the front.
- Turn the center screw clockwise to raise the rear of the tub and counterclockwise to lower it.

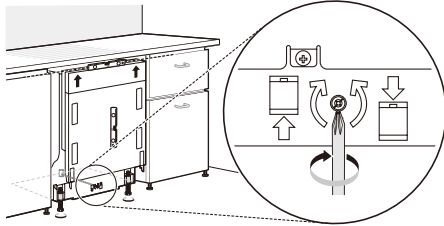

NOTE

- To avoid damaging the screw, do not use an electric screwdriver.

Securing Cabinet Panel to Dishwasher

Adjusting Appliance Height

- 1 Adjust the height of the appliance so the top of the door is as close to the height of the surrounding cabinet doors or drawer fronts as possible.

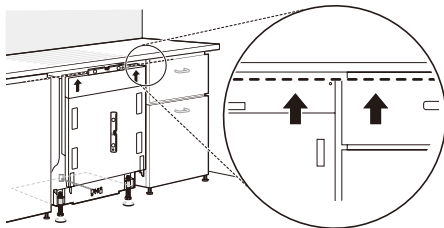

- 2 Measure the difference in height (x") between the top of the dishwasher door and the tops of the surrounding cabinet doors or drawers.

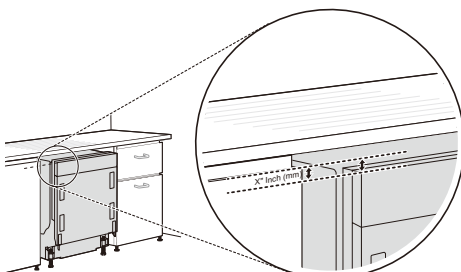

- 3 Using the measurement from step 2, make a mark x" up from the bottom of both rulers at the top of the provided installation template. Draw a line between the marks and trim off the top of the template at the line. Cut out the squares marked on the midline of the template so that you can see the center line.

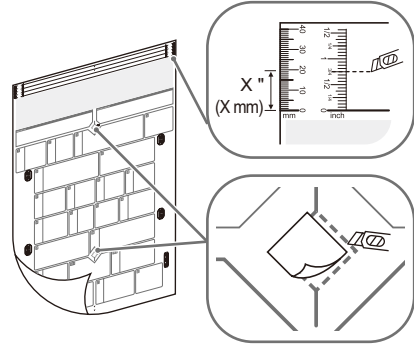

Adjusting Door Spring Tension

If the cabinet panel weighs between 17.6 lb (8 kg) and 24.2 lb (11 kg), adjust the door spring tension to make the door easier to open.

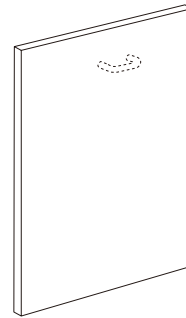

17.6 lb (8 kg) ≤  ≤ 24.2 lb (11 kg)

- 1 Open the dishwasher door to about 30°.
 - Do not adjust the spring strength with the dishwasher door fully open.

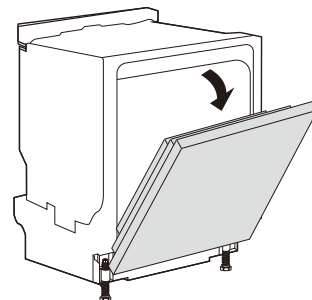

- 2 Use the door adjustment screws provided to adjust the door spring tension at the bottom of the dishwasher.

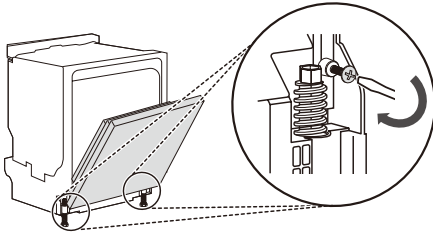

- 2 Align the top and center line on the installation template with the top and center line of the cabinet panel. Securely tape the installation template to the back of the cabinet panel.

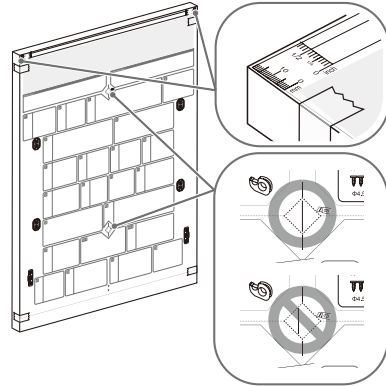

CAUTION

- Tighten the door adjustment screws completely.

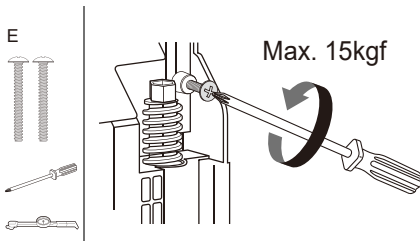
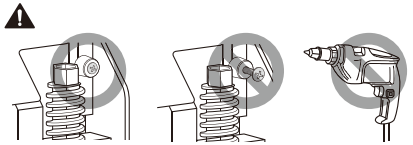

- Adjust the spring strength properly. If you do not adjust the spring strength, the door may fall open or spring closed unexpectedly.
- Tightening harder than 15 kgf may result in a crack in the screw boss.

- 3 Use a 1/16" (2 mm) diameter drill bit to drill 3/8" (10 mm) deep pilot holes at the 12 points marked on the template.

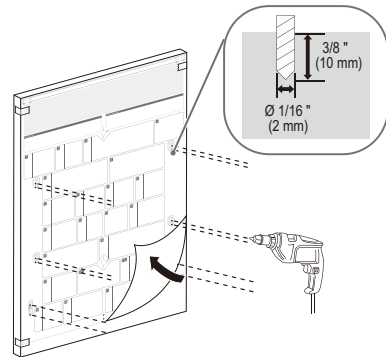

- 4 Remove the template, and attach the upper and middle panel brackets (provided) to the cabinet panel using the provided wood screws.

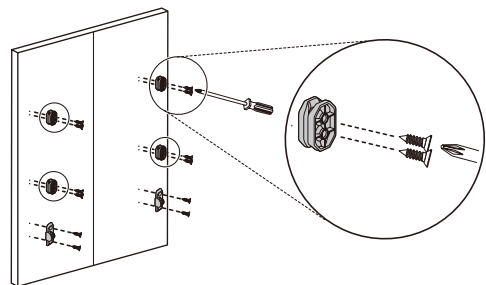

Preparing Cabinet Panel

- 1 Mark a center line lengthwise down the back of the cabinet panel.

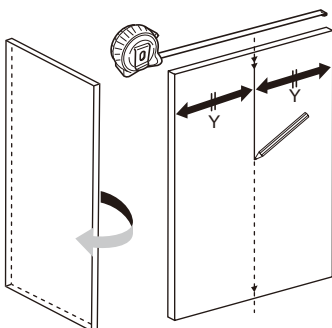

- 5** Attach the lower panel brackets (provided) to the cabinet panel using the provided wood screws.
- Position the lower panel brackets with the flat side facing out.

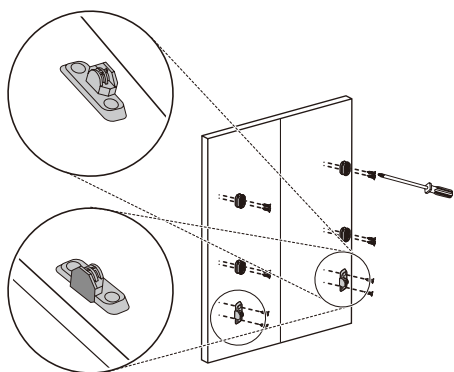

- 6** Attach a handle to the front of the cabinet panel before mounting the panel on the dishwasher. Make sure to countersink the screws so the panel slides smoothly.

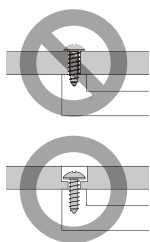
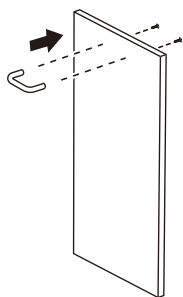

Mounting Cabinet Panel

- 1** Mount the cabinet panel on the dishwasher door by inserting the brackets on the panel into the bracket openings in the door.

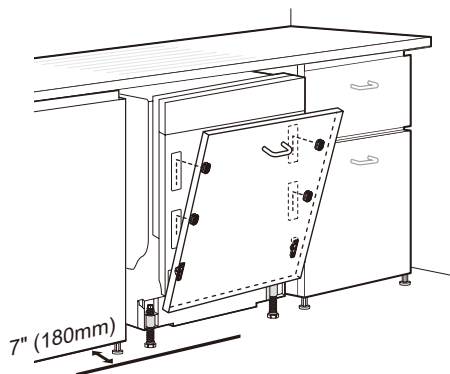

- 2** Attach the cabinet panel to the dishwasher door on the sides using the provided bracket screws.

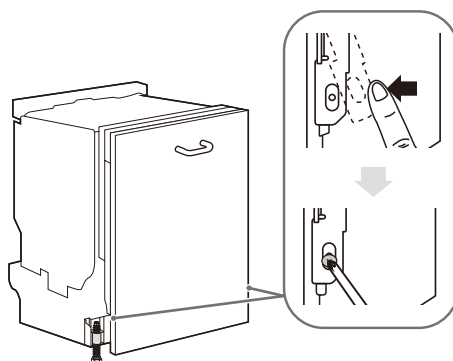

Securing Dishwasher to Cabinet Opening

There are 2 options for securing the dishwasher. If the countertop is made of wood or a material that can safely be drilled into, secure the dishwasher to the countertop with the provided brackets. If the countertop is granite, marble, or a material that cannot be drilled into, secure the dishwasher to the cabinet frame with the provided wood screws.

CAUTION

- Ensure the dishwasher is level and all leveling feet are in firm contact with the floor before attaching the dishwasher to the countertop or cabinet. If the dishwasher is not leveled properly, the door may not close properly or water may leak.

NOTE

- Installation brackets and screws can be found in the silverware basket.
- Use a magnetic screwdriver.
- Cover the filter hole with towels to prevent screws from falling down into the pump.

Securing Dishwasher to Countertop

Use the bracket screws provided to secure the brackets at the top of the dishwasher to the underside of the wood countertop.

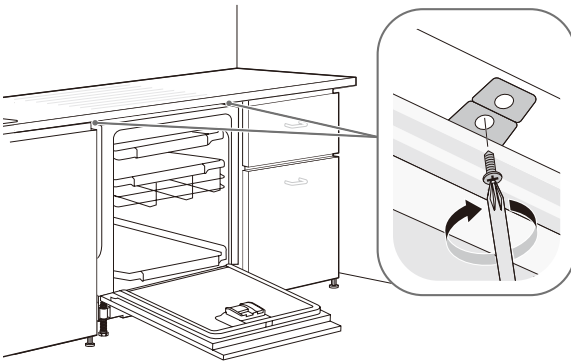

If desired, the dishwasher can also be secured to the cabinet frame using the instructions which follow.

Securing Dishwasher to Cabinet Frame

- 1 Remove the 2 plastic caps from the mounting bracket access holes.

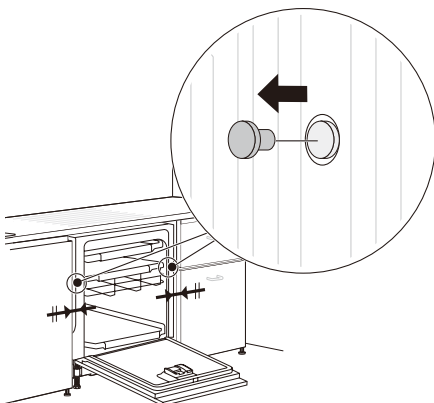

- 2 Drive a wood screw through the mounting bracket and into the cabinet frame.

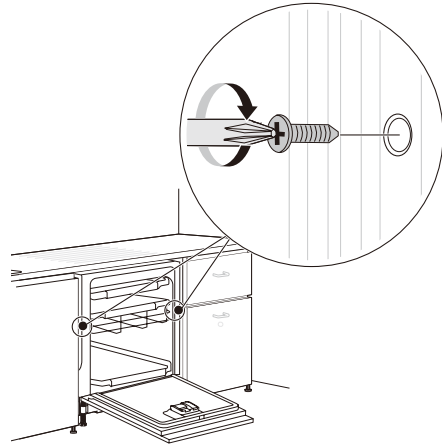

- 3 Reinstall the plastic caps.

Attaching Toe Kick

- 1 Attach the provided lower cover to the base of the dishwasher.

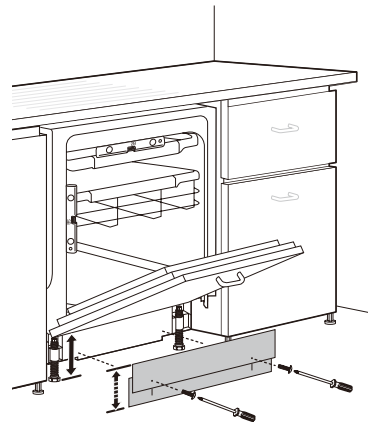

- 2 Attach a custom toe kick. If needed, use a saw to cut a notch in the top of the custom toe kick to provide clearance for the cabinet panel when opening the door.

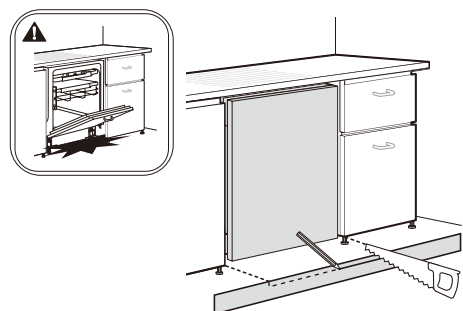

Final Installation Check

Check if the dishwasher is properly installed.

- 1 Turn on the circuit breaker.
- 2 Turn on the house water supply.
- 3 Make sure that the door opens and closes smoothly.
 - If necessary, level the dishwasher again.
 - If the door will not close, make sure the rack is level.

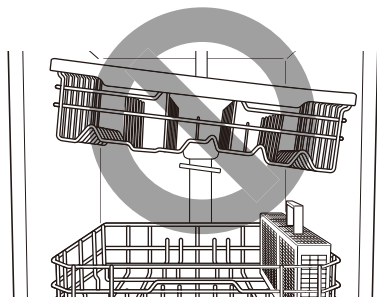

- Make sure that all packaging materials have been removed.

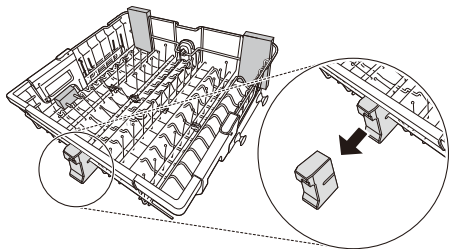

- 4 Power on the dishwasher and run a Turbo cycle to verify proper operation.
- 5 Check for leaks at the drain hose.
- 6 If a water leak is detected, press and hold the Start button for 3 seconds to cancel the wash cycle and automatically drain the water from the dishwasher. Tighten all water connections and run another cycle. Repeat until no leaks are detected.

Installation Check Error Codes

Refer to the chart below before calling for service.

Error Code	Possible Cause and Solution
OE Error	Drain hose is kinked or pinched. Feed the drain and water supply hoses through the hole under the sink. Then gradually slide the dishwasher into the cabinet while pulling on the hoses under the sink to take up any slack. This helps avoid kinking the hoses or trapping them beneath the dishwasher.
	Drain hose is connected to the disposal without removing the knockout plug. Remove the knockout plug from the disposal.
	Waste tee or disposal is clogged. Remove knockout plug on the waste tee or disposal.
IE Error	Water supply line is kinked under dishwasher. Feed the drain and water supply hoses through the hole under the sink. Then gradually slide the dishwasher into the cabinet while pulling on the hoses under the sink to take up any slack. This helps avoid kinking the hoses or trapping them beneath the dishwasher.
	House water supply is not turned on. Turn the water faucet on.

OPERATION

Using the Appliance

Before Using the Appliance

- Read the Important Safety Instructions.
- Connect to the hot water supply only. The water supply temperature should be a minimum of 120°F (49°C) for better washing performance and shorter cycle time.
- Follow the instructions for loading the dishwasher to ensure effective cleaning.
- Remove insoluble items such as bones, toothpicks, and pieces of paper while loading the dishwasher.

When Loading the Dishwasher

- 1 Only load items that are dishwasher-safe.
- 2 Remove solid, burned-on scraps from dishes prior to loading in the dishwasher.
- 3 Place bowls or containers at an angle to help water run off and speed the drying process.

NOTE

- Do not load utensils that are not heat-resistant or have decorative metal trim.

Checking Water Hardness Level

Method 1

- 1 Talk to the local municipal water department to check the water hardness in your area.
- 2 Set the water softening level on the appliance based on this information.

Method 2

Test the hardness of your water using the strips included with the appliance.

- 1 Pour a glass of water from the tap, and submerge the test area of the strip in the water for about a second. Do not hold the test strip under running water.
- 2 Shake off excess liquid from the strip and wait for 1 minute.
- 3 Check the color on the strip against the chart on the package to determine the water hardness.
- 4 Set the water softening level on the appliance.

Water Hardness Table

Hardness value	Hardness range					Water quality	Softening system level
	°d	°e	°f	mmol/l (Ca+Mg)	mg/l Ca		
0	<4	<5	<7	<0.7	<29	Soft	H0
75	4 - 7	5 - 9	7 - 13	0.7 - 1.3	29 - 50	↕	H1
125	7 - 14	9 - 17.5	13 - 25	1.3 - 2.5	50 - 100		H2
250	14 - 21	17.5 - 26	25 - 38	2.5 - 3.8	100 - 150		H3
375	>21	>26	>38	>3.8	>150	Hard	H4

Setting the Water Softening Level

For improved wash performance, adjust the water softening level based on how hard your water is. The water softener has 5 settings. The default setting is H2. Follow these steps to check the setting and adjust it if needed.

- 1 Press **Power** and **Half Load** buttons simultaneously.
 - Current setting shows in display.
- 2 Press the **Remote Start** button repeatedly to set the desired softener level from H0 to H4.
- 3 Press the **Start** button to save the setting.
 - The power turns off after saving.

NOTE

- The **Salt Refill** icon turns on in the display if the dishwasher salt needs to be refilled.
- Setting the softener level to H0 prevents the Salt Refill icon from turning on even when the dishwasher salt container is empty.

Filling the Dishwasher Salt

Fill the dishwasher salt container before starting a wash cycle. If more salt is needed, the Salt Refill icon will light up on the display, unless the softener level is set to H0.

⚠ CAUTION

- After filling the dishwasher salt container, run the Rinse cycle immediately to remove any salt residue from the inner tub and prevent corrosion.

- 1 Remove the lower rack and remove the cap of the salt container located on the left side of the filters.
- 2 If you plan to use the water softening system, you must prime it before using the appliance for the first time. To do this, mix 2.2 lb (1 kg) of dishwasher salt with 34 oz (1 liter) of water. Use the funnel provided to pour the mixture into the dishwasher salt container. For details on setting the softener level, see the Before Using the Appliance section.

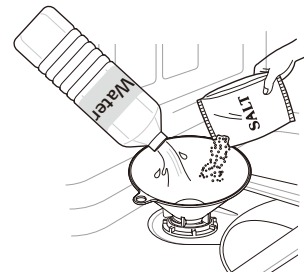

- 3 Tightly close the cover on the dishwasher salt container.
- 4 Run the Rinse cycle without dishes.

Salt Refill Frequency

	H1	H2	H3	H4
Cycles	200	60	30	10

- The table is based on using the Auto cycle.
- Different cycles may use different amounts of salt.

⚠ CAUTION

- To avoid product malfunction, do not pour detergent in the dishwasher salt container.
- Wipe any salt residue from around the salt container cover.
- Close the cover by aligning it horizontally and turning it clockwise. If the cover is not tightly closed, the salt solution can leak into the tub and cause corrosion.
- After refilling the dishwasher salt, run a Rinse cycle immediately without dishes to get rid of any salt residue which could cause rust or damage to the appliance.

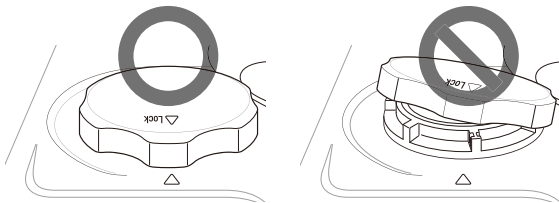

NOTE

- Dishwasher salt can be purchased online or from appliance retailers.

Quick Start

1 Load the Dishes

Scrape the dishes free of excess food, bones, and any other hard, non-soluble residue. Pull each rack out and load the dishes as described in this manual.

2 Measure the Detergent

Using the guidelines in this manual, fill the detergent cup with the recommended amount of detergent and close the lid. If a prewash is desired, the recess on top of the lid should also be filled with detergent.

3 Close the Door

4 Turn on the Dishwasher

To turn on the display panel, press the Power button.

5 Check the Rinse Aid

The Rinse Aid  icon will flash if the level of rinse aid in the dishwasher is low. Add rinse aid if the level is low to maintain the effectiveness of the dry cycle.

6 Select the Cycle and Options

Select the cycle and options that best fit the load by referring to the Cycle guide. The display will show the estimated time for the cycle and options selected.

7 Operate the Dishwasher Method 1

- Press the Start button and then close the door in less than four seconds to operate the dishwasher. If the door is not closed within four seconds, the white LED with time flashes, an audible tone is heard, and the cycle does not start.

Method 2

- Close the door first and then press the Start button to operate the dishwasher.

If the door is opened during the cycle, the dishwasher will stop. To resume the cycle, see methods 1 and 2 above.

NOTE

- If the door is opened during the cycle and is not closed within four seconds after selecting the Start button, or if the door is closed without pressing the Start button, the white LED with time flashes, an audible tone is heard, and the cycle does not start.

8 End of Cycle

When the cycle is complete, a chime will sound and the display will show **End** until the door is opened or **Power** is pressed. To save energy, press and hold **Delay Start** and **Remote Start** simultaneously for three seconds to set the End display to automatically turn off a few minutes after the cycle ends.

⚠ CAUTION

- Do not open the door during operation or immediately after the dishwasher has completed the wash cycle as the built up steam may cause scalding as the door is opened.

NOTE

- Empty the lower rack first and then the upper rack. This will avoid water dripping from the upper rack onto dishes in the lower rack.

Auto-Off

The dishwasher automatically turns off after four minutes of inactivity if paused or if no cycle is started.

Control Panel

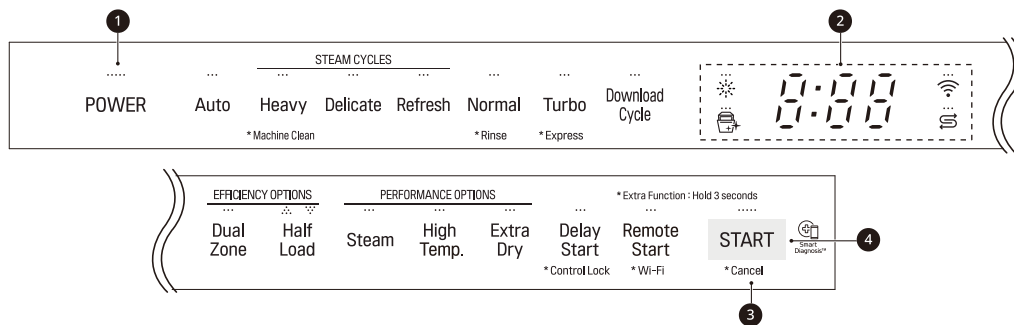

1 Power

- Press the **Power** button to turn power on and off.
- After the cycle is complete, the power automatically turns off for purposes of safety and economy.
- If there is a power surge, power outage, or disruption of any kind, power is automatically turned off for safety.
- When power is connected again, it will turn on automatically and resume the cycle.

2 Display

- **0:00: Digital Display**
 - The digital display on the control panel shows the ESTIMATED cycle time. When the cycle and options are selected, the display shows the total estimated time to complete those selections. During operation, the display shows the remaining estimated operating time.

NOTE

- The estimated time shown on the display does not include delay times for heating water, etc.
- If **Delay Start** is selected, the display shows the delay time in hours.
- Cycle time may vary depending on the soil level of your load.
- **[L]: Control Lock**
 - The Control Lock feature helps prevent settings from being changed during a cycle. Selecting this feature locks all of the buttons, except for the **Power** button, on the control panel. This feature does not lock the door.

- While a cycle is running, press and hold **Delay Start** for three seconds to activate or deactivate Control Lock.

- To start a new cycle, deactivate Control Lock.

- **☀️: Rinse Aid Icon**



- This icon illuminates when the rinse aid level is low. The LED automatically shuts off when the rinse aid is refilled or the level is set to 0.
- Refer to the Rinse Aid Dispenser Adjustment section.

- **🧼: Machine Clean**

- This cycle is for cleaning the inside of the dishwasher. Use the cycle without dishes in the machine. It eliminates residual soils, odor, white spots, and other dirt. Add citric acid or another cleaning agent for more effective results.
- Press and hold **Heavy** for three seconds to activate.

NOTE

- The **Machine Clean** 🧼 icon flashes every 30 cycles. To activate or deactivate the icon, press the **Delicate** button for three seconds.
- If the Steam option is added to a cycle, the Machine Clean 🧼 icon stays lit at the end of the cycle if the dishes were properly sanitized.

- : **Wi-Fi**
 - When the appliance is connected to the internet through a home Wi-Fi network, this icon illuminates.
 - Press and hold **Remote Start** for approximately three seconds to connect to the network.
- : **Salt Refill Icon**
 - This icon flashes when the salt level is low. The LED automatically shuts off when the salt is refilled.

3 Cancel

- The drain pump activates and the cycle cancels. Once the dishwasher finishes draining, the power turns off.
- Press and hold **Start** for three seconds to activate.

4 Start

- To operate the machine, either press **Start** and close the door within four seconds or close the door and press **Start**.
- If **Start** button is not pressed to start the cycle, an alert will sound.

Chime On/Off

- To activate or deactivate the button sounds, press and hold **Extra Dry** and **Delay Start** simultaneously for three seconds. The error alert sound cannot be turned off.

Cycles

Select your desired cycle.

Auto

This cycle senses the soil amount and soil toughness and is optimized to achieve the best cleaning.

Heavy

This cycle is for heavily soiled dishes and dishes with hardened on soil. The Heavy cycle defaults to the strongest spray intensity and uses it to wash heavily soiled dishes.

- This cycle has the added power of steam.

Delicate

Use this cycle to clean delicate items such as fine china and stemware.

- This cycle has the added power of steam.

Refresh

This cycle freshens up and warms dishes that have been unused for a long time.

- This cycle has the added power of steam.
- Do not use detergent when using this cycle.

Normal

This cycle is for moderately soiled, everyday loads.

Turbo

This cycle will clean heavily soiled dishes in an hour using slightly more energy and water.

- This cycle does not have drying. Select the **Extra Dry** option for better drying.

Download Cycle

Use a dedicated cycle downloadable via Wi-Fi or NFC.

NOTE

- Only the cycle code for the current Download cycle appears on the appliance. See the smartphone app for cycle codes, names, and more information about the available cycles.
 - Default Cycle : P1. Pots & Pans

Rinse

This cycle is a quick rinse for dishes that will not be washed immediately. The cycle rinses dishes that have excess soil to soften dried on residue. Rinsing the dishes helps prevent odors in the dishwasher. No detergent should be used.

- This cycle does not have drying.
- Press and hold **Normal** for three seconds to activate.

Express

This cycle will quickly clean lightly soiled dishes. (Time : 56 minutes)

- This cycle does not have drying. Select the **Extra Dry** option for better drying.
- Press and hold **Turbo** for three seconds to activate.



Options

Select the desired cycle and then select the options for that cycle.

Dual Zone

This option automatically sets the spray intensity to soft for the upper spray arm and strong for the lower spray arm. Place heavily soiled dishes like plates and bowls in the lower rack and lightly soiled dishes like cups and small plates in the upper rack to get the best results.

Half Load

This option washes intensively by selecting the upper or lower racks. For small loads, use just the upper or lower rack to save energy and time. By pressing the **Half Load** button, the settings ,  and the cancellation of the Half Load option are available.

Steam

This option adds steam at the start of the cycle to improve wash performance.

High Temp

Raises the main wash temperature to improve cleaning.

Extra Dry

Select the **Extra Dry** option for better drying performance. This option adds extra drying time to the cycle and raises the heated rinse temperature.

- When the rinse aid is empty, the **Extra Dry** option is selected automatically.

Delay Start

The Delay Start feature delays the start of a selected cycle. Each time the **Delay Start** button is pressed, the delay time increases by an hour. The delay time can be set from 1 to 12 hours, in one-hour increments.

Remote Start

Use a smartphone to control your appliance remotely. You can also monitor your cycle operation so you know how much time is left in the cycle. Once this function is enabled, you can start a cycle from the smartphone application. If the cycle is not started, the appliance will wait to start the cycle until it is turned off remotely from the application or this function is disabled.

Auto Open Dry (AOD)

Activate AOD to automatically open the door at the end of cycles that include drying to enhance the drying performance.

- The AOD feature is not available in all models.
- To activate or deactivate the AOD feature, press and hold the **High Temp** and **Extra Dry** buttons simultaneously for 3 seconds.
- The AOD feature is not available when the Rinse cycle is selected.
- If the Download cycle is selected, the AOD feature may operate even if it is deactivated. This is because downloadable cycles are designed to achieve the best wash performance for a specific purpose regardless of the appliance settings.
- The display shows whether the AOD feature is on or off.

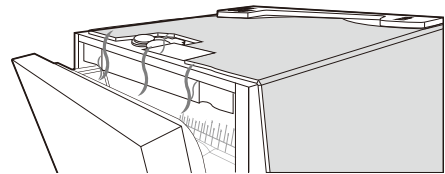

WARNING

- Keep children away from the appliance while the appliance is operating. Exposure to high temperature steam may cause scalding or burns.

Cycle/Option Guide

The cycle guide below shows the available options for each cycle.

Cycle		Auto	Heavy	Delicate	Refresh	Normal	Turbo	Express	Rinse	Machine Clean
Soil Level		all levels	heavy	light	light	all levels	heavy	light	light	
*Water Usage		12.8 - 19.9 L 3.4 - 5.3 gal	24.5 - 27.7 L 6.5 - 7.3 gal	17.0 - 18.9 L 4.5 - 5.0 gal	8.0 L 2.1 gal	9.2 - 23.0 L 2.4 - 6.1 gal	27.3 L 7.2 gal	17.4 L 4.6 gal	6.6 L 1.7 gal	12.3 L 3.2 gal
**Wash Time with Options (Mins.)		128-245	168-253	104-174	104-118	117-220	59-105	47-90	22	74-111
Available Options	Dual Zone	<input type="radio"/>	<input type="radio"/>			<input type="radio"/>	<input type="radio"/>	<input type="radio"/>		
	Half Load	<input type="radio"/>	<input type="radio"/>	<input type="radio"/>		<input type="radio"/>				
	High Temp	<input type="radio"/>	<input type="radio"/>			<input type="radio"/>	<input type="radio"/>	<input type="radio"/>		
	Steam	<input type="radio"/>	<input type="radio"/>	<input type="radio"/>	<input type="radio"/>	<input type="radio"/>				
	Extra Dry	<input type="radio"/>	<input type="radio"/>	<input type="radio"/>	<input type="radio"/>	<input type="radio"/>	<input type="radio"/>	<input type="radio"/>		
	Delay Start	<input type="radio"/>	<input type="radio"/>	<input type="radio"/>	<input type="radio"/>	<input type="radio"/>	<input type="radio"/>	<input type="radio"/>	<input type="radio"/>	<input type="radio"/>
	Remote Start	<input type="radio"/>	<input type="radio"/>	<input type="radio"/>	<input type="radio"/>	<input type="radio"/>	<input type="radio"/>	<input type="radio"/>	<input type="radio"/>	<input type="radio"/>
	Auto Open Dry	<input type="radio"/>	<input type="radio"/>	<input type="radio"/>	<input type="radio"/>	<input type="radio"/>	<input type="radio"/>	<input type="radio"/>		<input type="radio"/>

* Actual water consumption will vary depending on soil level and hardness of water.

** The actual running time and cycle time displayed may change depending on options chosen, soil level, water temperature, and hardness of water. Therefore, display time and actual running time can be different.

NOTE

- Options are not available for the Download cycle.
- When the Auto Open Dry (AOD) feature is activated, the temperature of the heated rinse is changed to 144°F (62°C).

Loading the Dishwasher

The extra tall tub allows loading of dishes, pans, or other utensils up to 11 3/4" high.

For effective washing performance, always follow the following instructions.

- Remove large particles of food debris from plates including bones etc. before loading.
- Items with burnt on food should be soaked prior to loading in the dishwasher.
- Deep pots or dishes should be placed upside down.
- Make sure that all items do not touch each other.

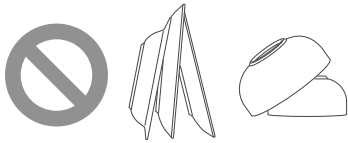

Non-Dishwasher Safe Items

The combination of high water temperature and dishwasher detergents may damage certain items. Do not wash the following items in the dishwasher.

- Copper or anodised aluminium
- Hand painted silver or gold leaf crockery
- Wood or bone handled utensils
- Iron or non rust proof utensils
- Plastic items which are not dishwasher safe
- Expensive ware such as silver and dishes with golden rings
- Fragile item such as crystal glasses

CAUTION

- Do not place pots or pans with plastic handles in the appliance as the handles may deteriorate due to the heat and detergent.
- Water proof or long lasting lipstick smudges on glasses may not be removed during the wash.

Loading the Lower Rack

Loading 10 Place Settings

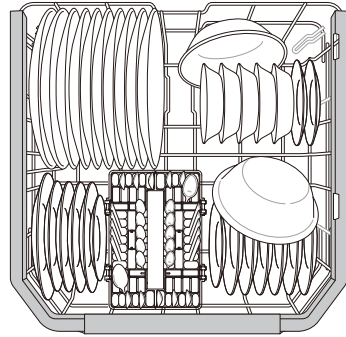

Loading 12 Place Settings

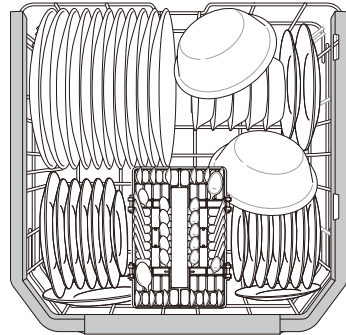

Lower Rack Loading Tips:

- Plates should be positioned upright and facing the center of the rack and pots, pans and large dishes must be turned upside down.
- Load dinner plates, dishes, soup bowls etc. between the tines.
- Load cookie sheets, cake pans and other large items on the sides or back of the rack. Loading these items in the front of the dishwasher can prevent the water spray from reaching the detergent dispenser.
- Make sure that pot handles and other large items do not stop the rotation of the spray arms.
- The lower rack should not be used for small items such as cups, wine glasses, or small plates. These items should be loaded in the upper rack.
- Make sure that large items do not interfere with the rotation of the spray arms, and do not prevent the detergent dispenser from opening.

Folding Down the Lower Tines

Fold tines down to fit larger dishes; pull tines back up to fit smaller dishes.

Case 1

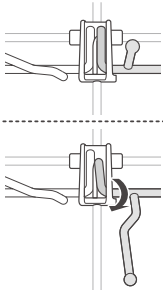

Case 2

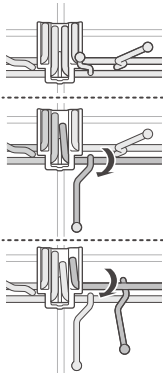

Loading Pots & Bowls

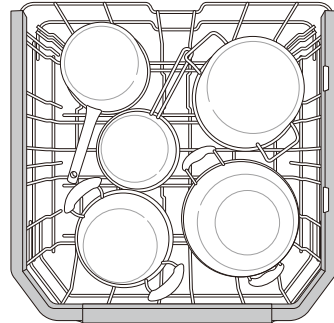
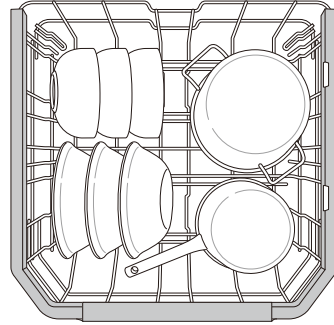

Loading Dishes & Pots

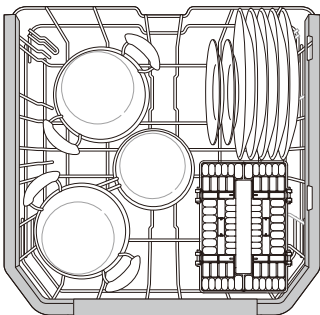
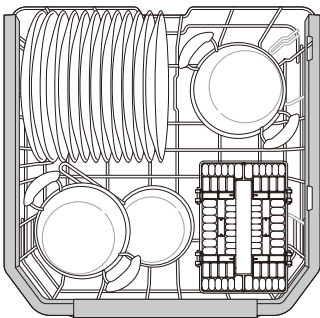

Loading the Silverware Basket

The silverware basket has separators to avoid scratching and tarnishing of delicate silverware.

Loading 10 Place Settings

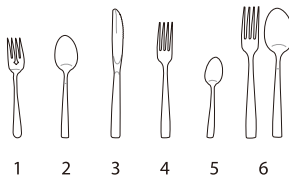
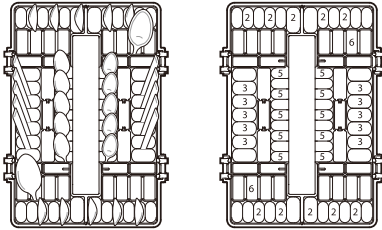

Loading 12 Place Settings

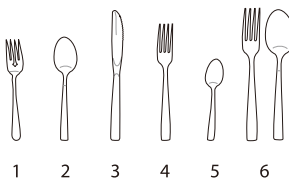
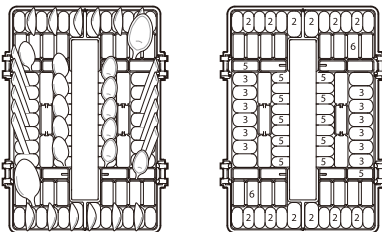

Silverware Loading Tips:

- For best cleaning results, use the top separators in the basket when loading silverware. The separators will prevent nesting of silverware.
- Load sharp items, such as knives, pointing down.
- When unloading the dishwasher, it is best to start with the silverware basket. Doing so will prevent water droplets from falling on your silverware from the upper rack.

WARNING

- Be careful when loading and unloading sharp items. Load sharp knives with the handles up to reduce the risk of personal injury.

Loading the Upper Rack

Loading 10 Place Settings

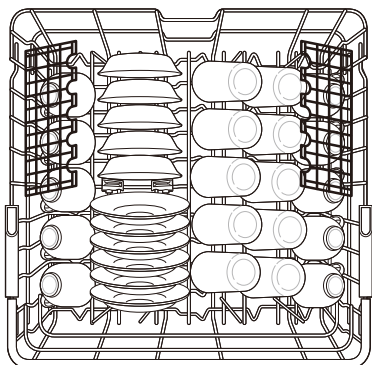

Loading 12 Place Settings

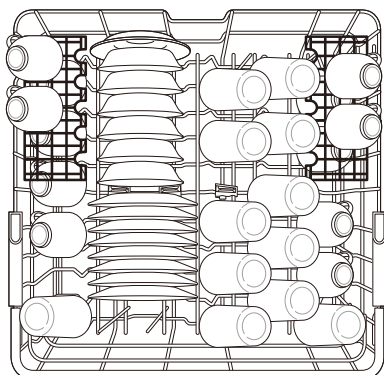

Upper Rack Loading Tips:

- Place cups and glasses in the rows between the rack tines. Placing them over the rack tines can lead to breakage and water spots.
- To avoid chipping, do not let stemware touch other items.
- Place items so that the open end faces down for cleaning and drying.
- Do not stack items on top of each other.
- Use the upper rack for small or delicate items such as small plates, cups, saucers, glasses, and dishwasher-safe plastic items.
- Cups, glasses, and bowls must be positioned upside down.
- Extra cups or cooking utensils can be laid on the fold down cup racks, which may also provide support for long-stemmed glasses.
- Make sure items do not interfere with the rotation of the spray arms above and below the upper rack.
- When loading larger items in the upper rack, such as wine glasses or taller cups, it may be necessary to remove the cutlery rack if one is present.

Loading the Cup Rack

Some models have cup racks that provide support for long-stemmed glasses.

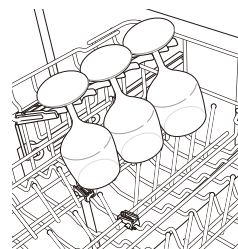

The cup racks can be folded up out of the way for tall glasses.

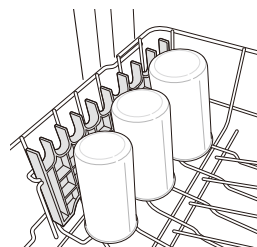

Removing and Replacing Cup Racks

The left and right cup racks are interchangeable and can be removed.

- 1 Slide cup rack down into its closed position.

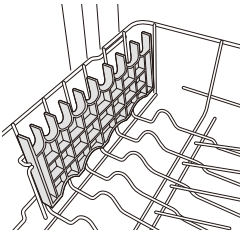

- 2 Locate assembly slot on cup rack and firmly pop rack off support bar on that side.
 - The rack on the left pops free at the back.
 - The rack on the right pops free at the front.

Assembly slot

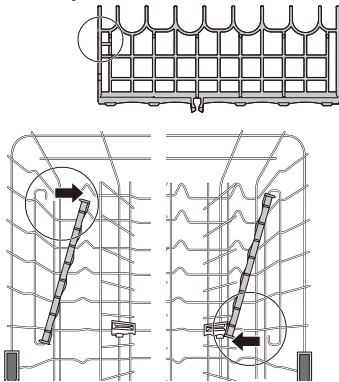

- 3 Slide cup rack off support bar on opposite side.

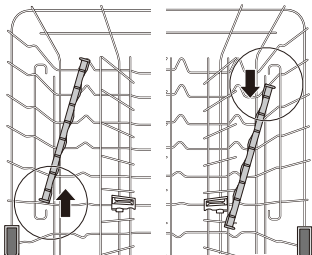

- 4 Reverse instructions to replace cup rack.

Folding Down the Upper Tines

Fold tines down to fit larger dishes; pull tines back up to fit smaller dishes.

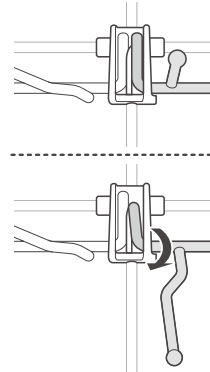

Loading Dishes & Pots

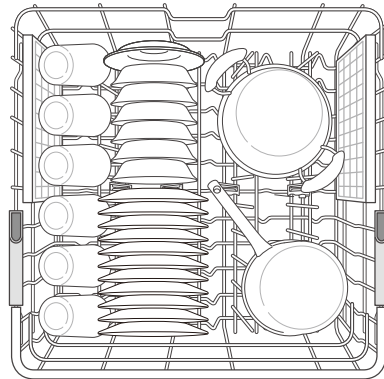

Height Adjustable Upper Rack

The upper rack adjusts up and down. Raise the upper rack to allow items up to 11 3/4" tall in the lower rack. Lower the upper rack to allow dishes up to 10 5/8" tall in the upper rack. The dishwasher ships with the upper rack raised.

There are three available positions for adjusting the height of the upper rack to create more space.

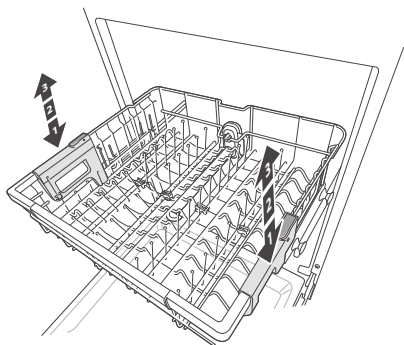

Lowering the Rack:

Hold the rack at the center of each side to support its weight. Then, push the button on each side to release the rack and lower it to the lower position.

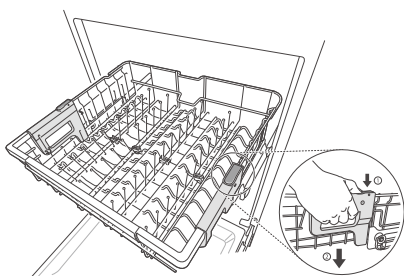

Raising the Rack:

Lift the rack at the center of each side until the rack locks into place in the upper position. It is not necessary to lift the lock levers to raise the rack.

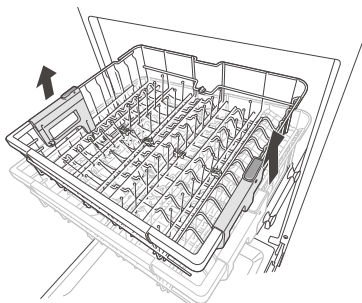

WARNING

- Before adjusting, ensure the rack is empty of all dishes. Otherwise dishes may get damaged or you may get injured.

NOTE

- Raise the upper rack without pushing the buttons on each side. Pushing the buttons when raising the rack will prevent the rack from locking into position.
- To set the rack to the middle position, it may be easier to lower the rack all the way down and then raise each side of the rack individually until it clicks into place.
- Before pushing the upper rack into the dishwasher, ensure the rack height is the same on both sides. If the height is not the same on both sides, the dishwasher door will not shut and the upper spray arm will not connect to the water inlet.

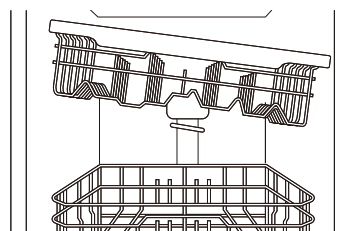

There is a 24 5/8 inches (56 mm) gain in height when the upper rack is moved to the lower position.

- After adjusting the rack levels, check that the spray arms are free to rotate.
- With the lower position of the upper rack, check if the bottom part of upper rack including spray arm is not disturbing items on the lower rack.
- When the upper rack is in the lower position, push in the upper rack first, and the lower rack later.
- Pull out the lower rack first, and the upper rack later.
- Raise the upper rack without pushing the buttons on each side. Pushing the buttons when raising the rack will prevent the rack from locking into position.
- To set the rack to the middle position, it may be easier to lower the rack all the way down and then raise each side of the rack individually until it clicks into place.

Removing the Snap-In Gliding Upper Rack

These instructions are for models with snap-in rack supports rather than wheeled rack supports.

CAUTION

- The snap-in upper rack should only be removed for servicing. If you need to remove the rack, wear gloves and handle the screwdriver carefully to avoid personal injury or damage to the dishwasher.

- 1 Pull the upper rack out until it stops. Remove any contents from the rack.
- 2 To remove the front rack supports from the rails, push the front hooks open with a flat-blade screwdriver while pulling the front of the rack up to snap the front rack support out of the hooks. Repeat to snap the front support out on the opposite side.

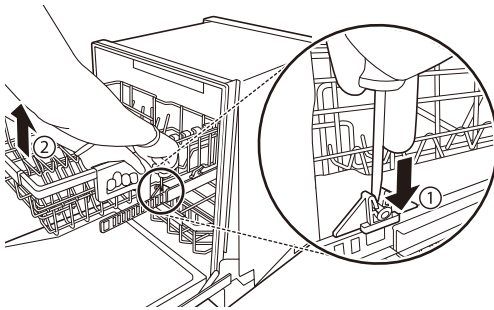

- 3 To remove the back rack supports from the rails, hold a side rail with one hand, lift the front of the rack, and firmly push the rack back to snap the support out of the hooks in the rear. Repeat on the opposite side.

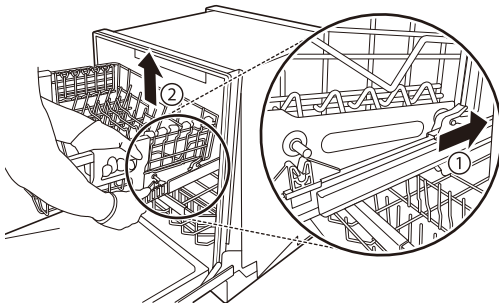

- 4 To replace the rack, place the back rack supports behind the rear hooks and pull the rack forward to snap the supports into the hooks. Then align the front rack supports with the front hooks and push the front of the rack down to snap the supports into the front hooks.

Loading the Cutlery Rack

The cutlery rack is best suited for flatware and most cooking or serving utensils. It can also fit small prep bowls and lids. The separators on the cutlery racks help keep flatware separated to avoid damage and improve cleaning.

NOTE

- For best cleaning performance, place flatware in the silverware baskets. Heavily soiled utensils or items with baked on foods should be placed in the middle rack or spoon basket for best performance.

Loading 10 Place Settings

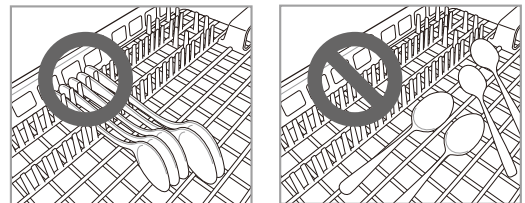
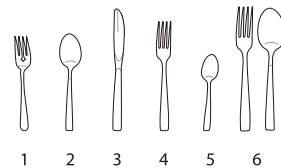
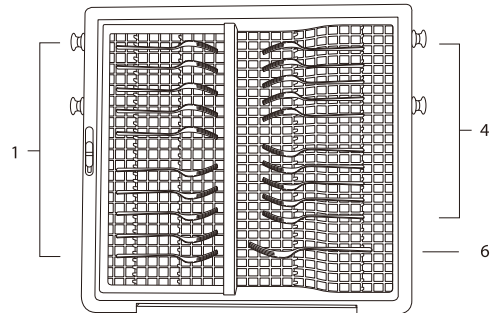

Height Adjustable Tray

The tray on the left side can be adjusted to a high or low position to accommodate utensils or cutlery of different sizes. Remove dishes before adjusting the tray. Adjust the tray by sliding the lever.

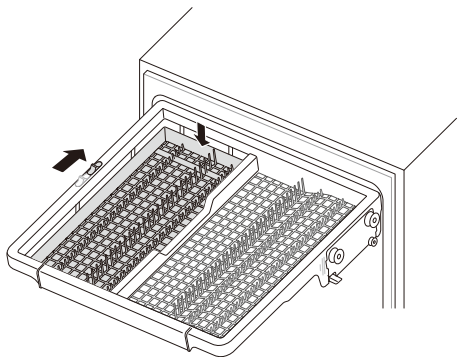

Removing the Cutlery Rack

The entire cutlery rack can be removed if more space is needed on the upper rack for larger items.

Always remove the cutlery from the rack before removing the rack.

Pull the rack out to the end of the rails. Then, lift the front of the rack so that the rollers clear the stop on the end of the rail. The rack can now be slid forward and removed from the rails.

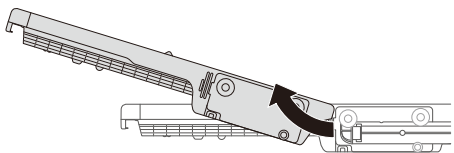

WARNING

- Be careful when loading and unloading items with sharp edges. Load sharp knives with the blade down to reduce the risk of injury.

Adding Cleaning Agents

Adding Detergent to the Dispenser

- Remove the label on the dispenser prior to running the dishwasher for the first time.
- The amount of detergent needed depends on the cycle, load size, and soil level of dishes.
- Put detergent into the detergent compartment before starting any cycle, except the Rinse cycle.

- 1 Push the button on the dispenser lid to open the cover.

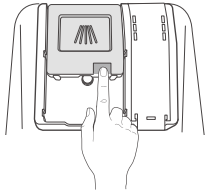

- 2 Add dishwashing detergent to the main wash compartment until the level is between the lines marked 15 and 25.

- Fill to over the 25 line for hard water or heavily soiled loads.
- Fill to the 15 line for soft water or lightly soiled loads.

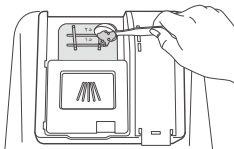

- 3 Push the detergent lid to slide the lid closed until it clicks.

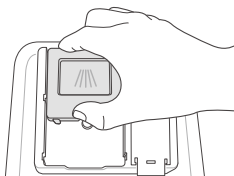

- 4 If a prewash is desired, fill the recessed prewash compartment area on the lid with detergent.

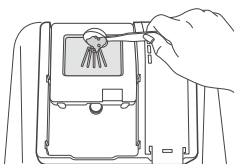

⚠ WARNING

- Dishwasher detergent and rinse aid contain chemical components, like all other household detergent. So, they must be kept out of the reach of children.

⚠ CAUTION

- Use only detergent intended for dishwashers. Incorrect detergent may cause the dishwasher to fill with suds during operation. Excess suds may reduce wash performance and may cause the dishwasher to leak.
- To avoid damaging the dispenser, do not pull up on the dispenser to close the dishwasher door.

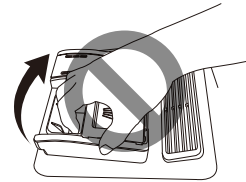

NOTE

- After completion of the wash program, check whether the detergent was completely washed out.
- Some dishwasher detergent tablets may become stuck in the dispenser due to their excessive size. Tablets can be placed onto the base of the wash tub next to the filter before starting the cycle.
- Too much detergent can leave a film on dishes and in the dishwasher, resulting in poor wash performance.
- If dishwasher detergent tablets are used without liquid rinse aid, the dishes and dishwasher interior will have excessive moisture. Select the Extra Dry option for better drying performance.
- Using liquid rinse aid improves drying performance by allowing water to drain off of dishes after final rinse.
- Do not use detergent tablets for shorter wash cycles. The tablet may not dissolve completely, causing detergent residue on dishes and inefficient cleaning.
- Using a wash booster helps remove spots, residue, and the white film caused by hard water. It does not help remove excess detergent residue.

Adding Rinse Aid to the Dispenser

The **Rinse Aid** indicator appears in the display when more rinse aid is needed.

The use of rinse aid is recommended to prevent water spots on dishes and to enhance drying performance.

- 1 Open the rinse aid lid by lifting up the flap.

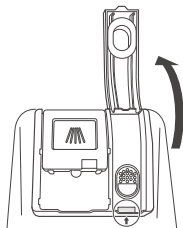

- 2 Add a liquid rinse aid to the maximum fill level. The rinse aid should be settled in the dispenser while filling, or air bubbles may result in poor drying performance. Avoid overfilling the dispenser.

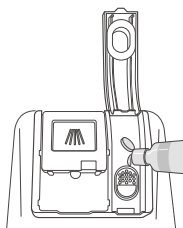

- 3 Close the lid to lock the dispenser. Rinse aid is dispensed automatically during the final rinse cycle.

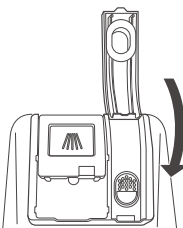

NOTE

- Only use liquid rinse aid in the dishwasher.
- Do not overfill the rinse aid dispenser.
- Wipe off any spilled rinse aid around the dispenser.

Rinse Aid Dispenser Adjustment

The dispenser has five adjustment levels. The dishwasher is programmed at the factory for a rinse aid dispenser level of 2. This can be checked and altered by using the buttons on the control panel.

- 1 Ensure the appliance is off.
- 2 Press **Dual Zone** and **Power** simultaneously to check the current setting.
- 3 Press **Remote Start** to change the rinse aid dispenser setting. Each press of the button changes the setting one step from L0 to L4.
- 4 Once the desired rinse aid dispenser setting is selected, press **Start** to save.

NOTE

- Adjust the setting higher if you have hard water and notice calcium buildup on your dishes.
- Setting the rinse aid control too low will contribute to spotting and streaking on dishes and poor drying performance.
- Setting the control too high can cause foaming, which will cause poor wash performance.

Refilling the Rinse Aid

How often the dispenser needs to be refilled depends on how often dishes are washed and the rinse aid setting used.

- The **Rinse Aid**  icon flashes when more rinse aid is needed, unless the rinse aid dispenser setting is set to L0.

SMART FUNCTIONS

The SIGNATURE KITCHEN SUITE Application

The **SIGNATURE KITCHEN SUITE** application allows you to communicate with the appliance using a smartphone.

The SIGNATURE KITCHEN SUITE Application Features

Monitoring

Check the current status, cycle, options, running time and cycle end time for the appliance on a single screen.

Download Cycle

Download new and specialized cycles that are not included in the standard cycles on the appliance.

Appliances that have been successfully connected can download a variety of specialty cycles specific to the appliance.

Only one cycle can be stored on the appliance at a time.

Once cycle download is completed in the appliance, the appliance keeps the downloaded cycle until a new cycle is downloaded.

Machine Clean Coach

This function shows how many cycles remain before it is time to run the Machine Clean cycle.

Smart Diagnosis™

This function provides useful information for diagnosing and solving issues with the appliance based on the pattern of use.

Settings

Set the Rinse Aid Dispenser Level, Machine Clean Reminder, Chime On/Off and Status Indicator Light.

When the cycle is complete or the appliance has problems, you have the option of receiving push notifications on a smart phone.

Push Alerts

Turn on the Push Alerts to receive appliance status notifications.

The notifications are triggered even if the **SIGNATURE KITCHEN SUITE** application is off.

NOTE

- If you change your wireless router, Internet service provider, or password, delete the connected appliance from the **SIGNATURE KITCHEN SUITE** application and connect it again.
- This information is current at the time of publication. The application is subject to change for product improvement purposes without notice to users.
- This feature is only available on some models.

Before Using the Application

- 1 Check the distance between the appliance and the wireless router (Wi-Fi network).
 - If the appliance is too far from the router, the signal strength becomes weak. It may take a long time to connect or installation may fail.
- 2 Turn off the Mobile data or Cellular Data on your smartphone.
 - For iPhones, turn data off by going to **Settings** → **Cellular** → **Cellular Data**.

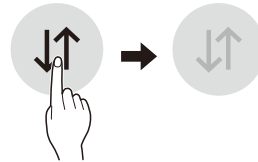

- 3 Connect your smartphone to the wireless router.

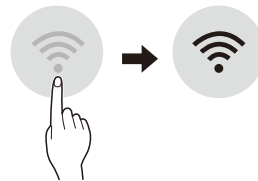

NOTE

- To verify the Wi-Fi connection, check that the **Wi-Fi**  icon on the control panel is lit.
- The appliance supports 2.4 GHz Wi-Fi networks only. To check your network frequency, contact your Internet service provider or refer to your wireless router manual.
- The SIGNATURE KITCHEN SUITE is not responsible for any network connection problems or any faults, malfunctions, or errors caused by network connection.
- The surrounding wireless environment can make the wireless network service run slowly.
- If the appliance is having trouble connecting to the Wi-Fi network, it may be too far from the router. Purchase a Wi-Fi repeater (range extender) to improve the Wi-Fi signal strength.
- The network connection may not work properly depending on the internet service provider.
- The Wi-Fi connection may not connect or may be interrupted because of the home network environment.
- If the appliance cannot be connected due to problems with the wireless signal transmission, unplug the appliance and wait about a minute before trying again.
- If the firewall on your wireless router is enabled, disable the firewall or add an exception to it.
- The wireless network name (SSID) should be a combination of English letters and numbers. (Do not use special characters.)
- Smartphone user interface (UI) may vary depending on the mobile operating system (OS) and the manufacturer.
- If the security protocol of the router is set to **WEP**, you may fail to set up the network. Please change it to another security protocol (**WPA2** is recommended) and connect the product again.

Installing the SIGNATURE KITCHEN SUITE Application

Search for the **SIGNATURE KITCHEN SUITE** application from the Google Play Store or Apple App Store on a smart phone. Follow instructions to download and install the application.

Wireless LAN Module Specifications

Model	LCW-003
Frequency Range	2412 MHz - 2462 MHz
Output Power (Max)	< 30 dBm

FCC Notice

The following notice covers the transmitter module contained in this product. This equipment has been tested and found to comply with the limits for a Class B digital device, pursuant to Part 15 of the FCC Rules. These limits are designed to provide reasonable protection against harmful interference in a residential installation. This equipment generates, uses, and can radiate radio frequency energy and, if not installed and used in accordance with the instructions, may cause harmful interference to radio communications. However, there is no guarantee that interference will not occur in a particular installation. If this equipment does cause harmful interference to radio or television reception, which can be determined by turning the equipment off and on, the user is encouraged to try to correct the interference by one or more of the following measures:

- Reorient or relocate the receiving antenna.
- Increase the separation between the equipment and the receiver.
- Connect the equipment into an outlet on a circuit different from that to which the receiver is connected.
- Consult a retailer or an experienced radio/TV technician for help.

This device complies with part 15 of the FCC Rules. Operation is subject to the following two conditions:

- 1) This device may not cause harmful interference and
- 2) This device must accept any interference received, including interference that may cause undesired operation.

Any changes or modifications in construction of this device which are not expressly approved by the party responsible for compliance could void the user's authority to operate the equipment.

FCC RF Radiation Exposure Statement

This equipment complies with FCC radiation exposure limits set forth for an uncontrolled environment. This transmitter must not be co-located or operating in conjunction with any other antenna or transmitter.

This equipment should be installed and operated with a minimum distance of 20 cm (7.8 inches) between the antenna and your body. Users must follow the specific operating instructions for satisfying RF exposure compliance.

Industry Canada Statement

This device contains licence-exempt transmitter(s)/ receiver(s) that comply with Innovation, Science and Economic Development Canada's licence-exempt RSS(s). Operation is subject to the following two conditions:

- (1) This device may not cause interference.
- (2) This device must accept any interference, including interference that may cause undesired operation of the device.

IC Radiation Exposure Statement

This equipment complies with IC radiation exposure limits set forth for an uncontrolled environment.

This equipment should be installed and operated with a minimum distance of 20 cm (7.8 inches) between the antenna and your body.

NOTE

- THE MANUFACTURER IS NOT RESPONSIBLE FOR ANY RADIO OR TV INTERFERENCE CAUSED BY UNAUTHORIZED MODIFICATIONS TO THIS EQUIPMENT. SUCH MODIFICATIONS COULD VOID THE USER'S AUTHORITY TO OPERATE THE EQUIPMENT.



Open Source Software Notice Information

To obtain the source code under GPL, LGPL, MPL, and other open source licenses, that is contained in this product, please visit <http://opensource.signatureskitchen.com>.

In addition to the source code, all referred license terms, warranty disclaimers and copyright notices are available for download.

SIGNATURE KITCHEN SUITE will also provide open source code to you on CD-ROM for a charge covering the cost of performing such distribution (such as the cost of media, shipping, and handling) upon email request to opensource@signaturekitchensuite.com. This offer is valid for three (3) years from the date on which you purchased the product.

Smart Diagnosis™ Feature

This feature is only available on models with the  or  icon.

Use this feature to help you diagnose and solve problems with your appliance.

NOTE

- For reasons not attributable to **SIGNATURE KITCHEN SUITE**'s negligence, the service may not operate due to external factors such as, but not limited to, Wi-Fi unavailability, Wi-Fi disconnection, local app store policy, or app unavailability.
- The feature may be subject to change without prior notice and may have a different form depending on where you are located.

Using SIGNATURE KITCHEN SUITE to Diagnose Issues

If you experience a problem with your Wi-Fi equipped appliance, it can transmit troubleshooting data to a smartphone using the **SIGNATURE KITCHEN SUITE** application.

Launch the **SIGNATURE KITCHEN SUITE** application and select the Smart Diagnosis feature in the menu. Follow the instructions provided in the **SIGNATURE KITCHEN SUITE** application.

Using Audible Diagnosis to Diagnose Issues

Follow the instructions below to use the audible diagnosis method.

Launch the **SIGNATURE KITCHEN SUITE** application and select the Smart Diagnosis feature in the menu. Follow the instructions for audible diagnosis provided in the **SIGNATURE KITCHEN SUITE** application.

- 1 Place the mouthpiece of the phone close to the **Smart Diagnosis™** icon. Do not press any other buttons.
- 2 Press and hold **Download Cycle** until a countdown displays on the appliance.
- 3 Keep the phone in place until the tone transmission has finished. The display will count down the time. Once the countdown is over and the tones have stopped, the diagnosis will be displayed in the application.

NOTE

- For best results, do not move the phone while the tones are being transmitted.

Remote Start

Use a smart phone to control the appliance remotely or check to see how much time is left in the cycle.

Using Remote Start

- 1 Load the dishes into the dishwasher.
- 2 Press the **Power** Button.
- 3 Make sure that the Wi-Fi is connected.
- 4 Press the **Remote Start** button and close the dishwasher door to enable the Remote Start function.
- 5 Start a cycle from the **SIGNATURE KITCHEN SUITE** application on your smart phone.

NOTE

- Once the Remote Start mode is enabled, you can start a cycle from the Signature Kitchen Suite smartphone application. If the cycle is not started, the machine will wait to start the cycle until it is turned off remotely from the application or the Remote Start mode is disabled.
- The door must be closed in order to activate the Remote Start mode.
- If you press **Start** after pressing **Remote Start**, the Remote Start function will be disabled.

Disabling Remote Start

While Remote Start is activated, open the dishwasher door or press the **Remote Start** button twice quickly with the door closed.

Download Cycle

Download new and specialized cycles that are not included in the standard cycles on the appliance. Appliances that have been successfully connected can download a variety of specialty cycles specific to the appliance. Only one cycle can be stored on the appliance at a time. Once cycle download is completed in the appliance, the appliance keeps the downloaded cycle until a new cycle is downloaded.

MAINTENANCE

To maintain performance and prevent trouble, it is important to check the outside and inside of the dishwasher, including filters and spray arms, at regular intervals.

WARNING

- When cleaning the outside and inside of the dishwasher, do not use benzene or thinner. Otherwise, it may cause fire or explosion.
- To prevent injury during care and maintenance or cleaning, wear gloves and/or protective clothing.

NOTE

- If you have not used the dishwasher for a long time, refresh the inside by running the Machine Clean cycle without detergent. When the cycle is finished, clean the inside and outside of the dishwasher according to the Maintenance instructions.

Cleaning the Exterior

- In most cases, the exterior of the dishwasher can be cleaned with a soft damp cloth or sponge, then dried with a soft cloth. If the dishwasher has a stainless steel exterior, use a stainless steel cleaner.

CAUTION

- If cooking oil is spilled on the exterior of the product, wipe it off immediately. Do not clean the exterior of the product with cleaners which contain alcohol, thinners, bleach, benzene, flammable liquids, or abrasives. These substances may discolor or damage the appliance.

Cleaning the Interior

- Clean the interior of the dishwasher periodically with a soft, damp cloth or sponge to remove food and dirt particles.
- To remove white spots and odor from inside the dishwasher, run an empty cycle, without detergent, with one cup of white vinegar in a dishwasher safe glass or bowl placed on the upper rack. (Vinegar is an acid and with constant use it could damage the appliance.)

Seasonal Maintenance and Storage

- If you will be absent for an extended period of time during warmer months, close the water valve and disconnect the power cord, or turn off the circuit breaker. Clean the filter, tub and dispenser to prevent odor.
- If you will be absent for an extended period of time during colder months and there is a possibility of freezing temperatures, winterize the water supply lines and the dishwasher itself. Winterization must be performed by qualified service personnel.

Clogged Drain Air Gap or In-Sink Disposal

Check the drain air gap or in-sink disposal if the dishwasher is not draining well.

Cleaning the Air Gap

- 1 Turn off the dishwasher.
- 2 Remove the air gap cover and the plastic cap underneath it.



- 3 Clean out any debris with a toothpick or brush.

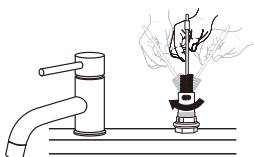

- 4 Replace the plastic cap and air gap cover.



NOTE

- The drain air gap and disposal are external plumbing devices that are not part of the dishwasher.
- The warranty provided with the dishwasher does not cover service costs directly associated with the cleaning or repair of the external drain air gap and disposal.

Cleaning the Filters

- 1 Remove the lower rack and position the bottom spray arm so a wider vee is open to the front.
- 2 Turn the inner filter counter-clockwise and take out the assembled inner filter and stainless steel filter. With the filters removed, check the sump opening and remove any foreign materials, if needed.

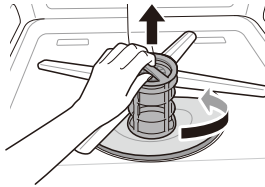

- 3 Clean the filters with a soft brush under running water. Reassemble the filters before reinstalling them.

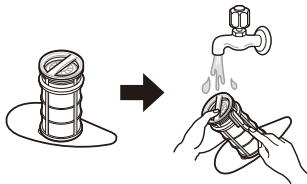

- 4 To replace the assembled filters, position the spray arm so the wider vee is toward the front. Fit the filters back into the filter holder and secure them by turning the inner filter clockwise until it clicks into place.

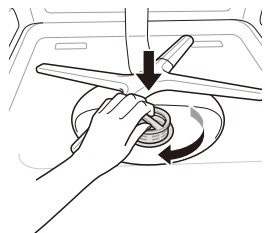

⚠ WARNING

- Be cautious of sharp edges when handling the stainless steel filter.

⚠ CAUTION

- Remove food residue caught in filters to prevent the build up of odor-causing bacteria and possible drainage problems.

NOTE

- For best wash performance, clean the filter after each load. If food debris remains in the filter, it may cause an odor.
- In areas with hard water, clean the filter at least once a month with a soft brush.
- Clean the filters using non-abrasive materials and warm running water.
- Make sure the filter is assembled correctly before starting a cycle. When assembling, rotate it firmly until it clicks.

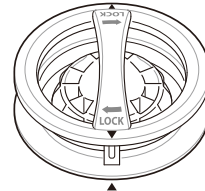

Recommended Filter Cleaning Schedule

Number of Loads Per Week	If you wash dishes before loading	If you scrape and rinse dishes before loading	If you only scrape dishes before loading	If you do not scrape or rinse dishes before loading
1-3	Every 6 months	Once a year	Four times a year	Once a month
4-7	Every 6 months	Once a year	Four times a year	Twice a month (every 15 days)
8-12	Every 6 months	Every 6 months	Every 1.5 months	Every week
13-14	Every 6 months	Every 6 mont	Every 1.5 months	Twice a week

Cleaning the Spray Arms

If the spray arm holes are blocked by any food residue, dishes may not be cleaned well due to improper water spray.

It is recommended that the spray arms be cleaned once every two weeks.

Cleaning the Lower Spray Arm

- 1 Make sure that the water jet holes are not blocked by food particles.
- 2 If any food residue blocks the spray arm holes, remove it with a pin or any sharp tool.

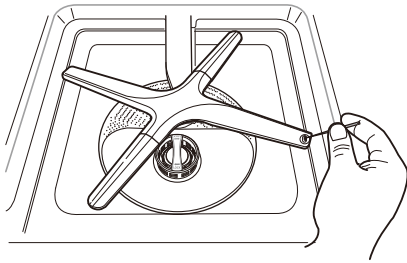

CAUTION

- To avoid breaking the rolling spray arm sections, do not pull or manually rotate them.

Cleaning the Upper Spray Arm

- 1 Pull the upper rack forward. Make sure that the water jet holes are not blocked by food particles.
- 2 When cleaning is necessary, remove the upper spray arm by turning the nut on the bottom of the spray arm $\frac{1}{8}$ turn counter-clockwise and pulling down.

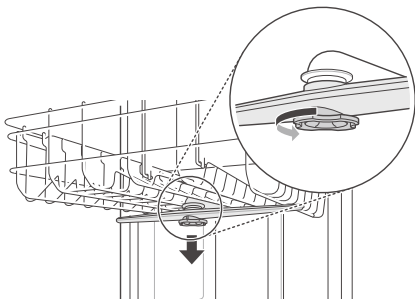

- 3 Remove food particles by rinsing or shaking the spray arm.
- 4 If any food residue blocks the spray arm holes, remove it with a pin or any sharp tool.

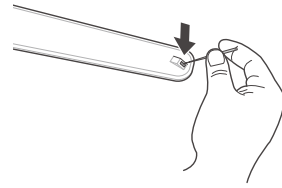

- 5 After removing the food residue, clean the spray arms holes under running water.
- 6 After cleaning the upper spray arm, press it up into place. Turn the nut $\frac{1}{8}$ turn clockwise to make sure that the nut locks back into place.

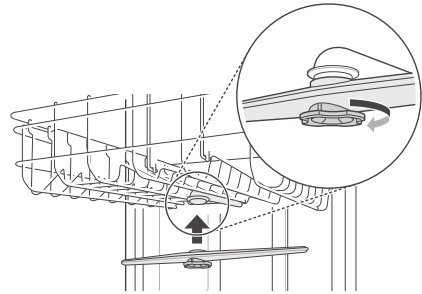

- 7 After assembly, check whether the spray arms rotate freely.

TROUBLESHOOTING

FAQs: Frequently Asked Questions

Q: Does this dishwasher require a rinse aid to be used?

A: Rinse aid is strongly recommended to enhance the drying performance of the dishwasher. In order to be more energy efficient, the Auto Open Dry (AOD) option does not use a heating element to assist in drying, so a rinse aid plays an integral role in the drying process. If a rinse aid is not used, water may remain on the dishes and the tub. Rinse aid helps to ensure that the majority of the water has been sheeted off of the dishes at the end of the rinse and that the load is ready for the dry cycle.

Q: What can be done if my dishes have a cloudy, white film on them after a wash?

A: The cloudy film is usually caused by minerals in the water reacting with the dishwasher detergent. First, be certain not to use too much detergent. Refer to Adding Detergent to the Dispenser section for recommended detergent amounts. Add an extra rinse to the cycle. Adjust the water softening level to reduce film caused by hard water. Refer to the Setting the Water Softening Level section.

Q: How do I remove white film on the tub?

A: Measure 3 tbsp. (40 g) of citric acid powder and use it to fill the main detergent compartment. Run a **Machine Clean** cycle. Do not use detergent.

Q: What steps can I take to improve drying results?

A: Drying performance is directly affected by the amount of heat that remains in the tub after the heated rinse is performed. If your dishwasher is far away from your home's hot water heater, it may be necessary to run the hot water tap in the sink before starting a wash cycle, to ensure that cool water is purged from the hot water lines. This will ensure your dishwasher has a consistent supply of hot water from start to finish. Using the High Temp setting also aids in keeping the inner drum temperature and dishes hotter before drying begins.

SIGNATURE KITCHEN SUITE dishwashers are designed to be used in conjunction with a rinse aid. Using a rinse aid will maximize the amount of water that has already been sheeted away from the dishes before the dry cycle begins. If a rinse aid is used and the performance still needs a boost, adjust the amount of rinse aid used. 2 is the default setting, but if necessary set the level to 3 so more rinse aid is used.

Water tends to bead rather than sheet off plastic and nonstick surfaces, making them more difficult to dry. If washing plastic items in a Normal cycle, select the **Extra Dry** or **Auto Open Dry** option or both for better drying results. When the rinse aid is empty, the **Extra Dry** option is selected automatically.

Allow the dishwasher to completely finish the dry cycle before opening the door. If the door is opened in the middle of the dry cycle, the heat that is necessary for the hybrid dry system to work will escape. This will cause all of the dishes inside to remain wet once the cycle finishes.

Q: What is the Auto Open Dry system?

A: The Auto Open Dry (AOD) option automatically opens the door slightly at the end of cycles that include drying. This allows steam to escape and fresh air to enter the tub, so even plastic items get dryer. Install the aluminum tape provided to protect the underside of the counter.

NOTE

- Rinse aid is required to enhance the drying performance. If no rinse aid is used, water may remain on the dishes and the tub.

Q: Why am I hearing a whistling sound from the dishwasher?

A: It is important to determine the duration of the noise and when it happens (what part of the cycle). When water is drawn into the dishwasher, a whistling noise can be heard. This is normal. If the water pressure is too high, it will be louder, so it may be necessary to adjust the water valve to lower the pressure if the noise is too loud.

Q: What kinds of dishes can be placed in the dishwasher?

A: Make sure items are marked as "dishwasher safe" before washing them in the dishwasher. For unmarked items, check with the manufacturer. Plastic dishware will not dry as effectively as glass and metal dishware. Plastic items do not retain heat as well as glass and metal dishware. Plastic cups and dishes may require some hand drying before being put away at the end of the cycle.

Q: Can I perform a drain only cycle?

A: To drain standing water, press and hold **Start** for three seconds until the cycle stops. Once the dishwasher finishes draining, the power turns off.

Q: Why does my dishwasher continuously chime if I open the door during a cycle or right after the cycle has finished?

A: This is normal. The dishwasher is letting you know that the interior temperatures of the unit are hot and to use caution when placing your hands inside. Once the unit has cooled down, the chiming will stop.

Q: What is Control Lock and how is it activated?

A: **Control Lock** is a feature that prevents the controls from being changed during the cycle. It does not prevent the door from being opened or the unit from being powered off. To activate or deactivate, press and hold **Delay Start** for three seconds.

Q: Can I add an extension to the drain hose?

A: If an extension drain hose is required, use $\frac{5}{8}$ " or $\frac{7}{8}$ " inside diameter, 2-3 ft. length hose and a coupler for connecting the two hose ends.

Q: An LED is blinking, the machine is chiming, and the dishwasher won't start. What is wrong with the dishwasher?

A: This is a safety feature. The door must be closed within four seconds of pressing the Start button. If the door is not closed within four seconds, an LED flashes, an audible alert sounds, and the dishwasher does not operate. To start the dishwasher, open the door and either close the door and press **Start** (front controls) or press **Start** and close the door within four seconds (top controls).

Q: Should I rinse my dishes before I load them in the dishwasher?

A: No, you don't need to pre-rinse the dishes before loading especially if using the Normal and Auto cycles. The dishwasher washes dishes clean without pre-rinsing.

Before Calling for Service

The appliance is equipped with an automatic error-monitoring system to detect and diagnose problems at an early stage. If the appliance does not function properly or does not function at all, check the following before you call for service.

Problem	Possible Cause	Solutions
Dishwasher will not operate.	Start button is not pressed.	<ul style="list-style-type: none"> Press the Start button.
	Door is not completely closed.	<ul style="list-style-type: none"> Make sure that the door is completely closed and latched.
	Power supply or power cord is not connected.	<ul style="list-style-type: none"> Connect the power supply or power cord properly.
	Fuse is blown or circuit breaker tripped.	<ul style="list-style-type: none"> Replace the fuse or reset the circuit breaker.
	Control Lock is activated.	<ul style="list-style-type: none"> Deactivate Control Lock.
Dishwasher operates too long.	Dishwasher is connected to cold water.	<ul style="list-style-type: none"> Check the water supply connection or water heater setting. (Heating cold water takes longer.)
Odor	The previous cycle was stopped before completion and residual water remains in the dishwasher.	<ul style="list-style-type: none"> Turn on the power, run the Cancel cycle option to remove the residual water, then run the Turbo cycle using detergent but with the dishwasher empty.
	There is food in the bottom of the unit or in the filter.	<ul style="list-style-type: none"> Clean the filter and the interior according to the Maintenance section of the owner's manual.
	Unwashed dishes are left in the unit for a long time.	<ul style="list-style-type: none"> Cycle with one cup of white vinegar in a dishwasher safe glass or bowl placed on the upper rack. (Vinegar is an acid, and with constant use it could damage your appliance.)
	After cleaning, the product may smell like detergent.	<ul style="list-style-type: none"> There's nothing wrong with the product, so be assured of using it.
Water remains in tub after completion of cycle.	Drain hose is kinked or clogged.	<ul style="list-style-type: none"> Adjust hose or clear blockage.
Food soil remains on dishes.	Improper cycle selection.	<ul style="list-style-type: none"> Select correct cycle based on soil level and type of dishware being washed.
	Water temperature is too low.	<ul style="list-style-type: none"> Check water supply connection or water heater setting.
	Dishwashing detergent was not used.	<ul style="list-style-type: none"> Use recommended detergent.
	Low inlet water pressure.	<ul style="list-style-type: none"> Water pressure should be between 20 and 80 psi.
	Water jet holes on spray arms blocked.	<ul style="list-style-type: none"> Clean the spray arms.
	Improper loading of dishes.	<ul style="list-style-type: none"> Make sure dishes do not block spray arm rotation or interfere with detergent dispenser.
	Filters are clogged.	<ul style="list-style-type: none"> Clean filters.

Problem	Possible Cause	Solutions
Cloudiness on glassware.	Combination of excessive detergent and hard water.	<ul style="list-style-type: none"> Use less detergent and use a rinse aid to minimize the problem.
Black or gray marks on dishes.	Aluminum items rubbing dishes during cycle.	<ul style="list-style-type: none"> Reposition the dishes.
Yellow or brown film on inside surfaces of dishwasher.	Coffee or tea stains.	<ul style="list-style-type: none"> Eliminate the stain by using a stain removal product.
Spots and filming on dishes.	Low water temperature.	<ul style="list-style-type: none"> Water supply should be at least 120 °F for best wash performance.
	Overloading.	<ul style="list-style-type: none"> Do not overload the dishwasher.
	Improper loading.	<ul style="list-style-type: none"> See the Operation section.
	Insufficient water pressure.	<ul style="list-style-type: none"> Water pressure should be between 20 and 80 psi.
	Insufficient detergent.	<ul style="list-style-type: none"> Add the recommended amount of detergent. See the Operation section.
	Rinse aid dispenser is empty.	<ul style="list-style-type: none"> Refill rinse aid dispenser.
	Hard water buildup in the tub.	<ul style="list-style-type: none"> Remove all dishes, silverware and silverware holder from dishwasher. Only racks should remain in tub. For best results, use citric acid powder (can be found in canning sections of most grocery stores or online). Measure 3 tablespoons (40 g) of citric acid powder. Fill main wash compartment with measured powder. If you cannot find citric acid powder, pour approximately one cup (200-300 mL) of white vinegar into shallow bowl and place in upper rack. Run Machine Clean cycle. Do not use detergent.
Noise	Some level of noise is normal during operation.	<ul style="list-style-type: none"> Detergent cover opening. Drain pump at the beginning of drain cycle.
	The dishwasher is not level.	<ul style="list-style-type: none"> Adjust leveling feet.
	Nozzle arm knocking against dishes.	<ul style="list-style-type: none"> Reposition the dishes.
Dishes don't dry.	Rinse agent dispenser empty.	<ul style="list-style-type: none"> Check and refill the rinse agent dispenser if empty.
	Dish was taken out of the cabinet too soon.	<ul style="list-style-type: none"> Wait until the dishes have cooled before unloading the dishwasher.
LEDs do not illuminate.	Power is not connected.	<ul style="list-style-type: none"> Connect power supply.
Spray arms do not rotate smoothly.	Holes of spray arms are blocked by food particles.	<ul style="list-style-type: none"> Clean the holes of spray arms.

Problem	Possible Cause	Solutions
Upper rack is crooked.	Rack is poorly adjusted.	<ul style="list-style-type: none"> See the Height Adjustable Upper Rack section.
Dishwasher continuously chimes when the door is opened, during or right after a cycle has completed.	This is a safety measure. Contact with escaping steam or the hot contents of the dishwasher could result in injury.	<ul style="list-style-type: none"> Close the door until the dishwasher and dishes have cooled down. The chiming will stop if the door is closed or the interior temperature has cooled.
Dishwasher chimes if panel is touched during operation.	Bumping into or touching the control panel during operation may result in a disabled button sound. Only the Power, Start, and Control Lock buttons are enabled during operation to prevent cycle settings from being changed inadvertently.	<ul style="list-style-type: none"> Button sounds can be turned off by pressing and holding Extra Dry and Delay Start simultaneously for three seconds. The end of cycle chime and safety alert sounds will still sound.
Dishwasher did not finish cycle.	Door was opened during cycle.	<ul style="list-style-type: none"> If the door is opened during a cycle, the Start key must be pressed within 4 minutes or the machine turns off and all settings are lost.
Leaking in front of unit	Dishwasher not leveled properly.	<ul style="list-style-type: none"> Verify the unit is level from side to side and from front to back. See leveling instructions in the Installation section.
	Wrong detergent used.	<ul style="list-style-type: none"> If excessive sudsing is causing the leak, allow the foam to subside for 24 hours then clean the inside of the tub with milk.
Trouble connecting the appliance to a home Wi-Fi network using the smartphone application.	The password for the Wi-Fi that you are trying to connect to is incorrect.	<ul style="list-style-type: none"> Find the Wi-Fi network connected to your smartphone and remove it, then register your appliance on SIGNATURE KITCHEN SUITE.
	Mobile data for your smartphone is turned on.	<ul style="list-style-type: none"> Turn off the Mobile data of your smartphone and register the appliance using the Wi-Fi network.
	The wireless network name (SSID) is set incorrectly.	<ul style="list-style-type: none"> The wireless network name (SSID) should be a combination of English letters and numbers. (Do not use special characters.)
	The router frequency is not 2.4 GHz.	<ul style="list-style-type: none"> Only a 2.4 GHz router frequency is supported. Set the wireless router to 2.4 GHz and connect the appliance to the wireless router. To check the router frequency, check with your Internet service provider or the router manufacturer.
	The appliance is too far from the router.	<ul style="list-style-type: none"> If the appliance is too far from the router, the signal may be weak and the connection may not be configured correctly. Move the router closer to the appliance.
P1, P2, P3, or P4 appears in display.	The Download cycle is selected.	<ul style="list-style-type: none"> This is not an error code. This code indicates the current Download cycle.

Problem	Possible Cause	Solutions
Codes starting with n, U, d, or t appear in the display.	Test mode is selected.	<ul style="list-style-type: none"> This is not an error code. This code is used when testing the dishwasher. Power the unit off and on and the code will disappear.
L0, L1, L2, L3 or L4 appears in display.	Rinse Aid Level setting mode is selected.	<ul style="list-style-type: none"> This is not an error code. This code indicates the current rinse aid level. For more information, refer to the Adding Cleaning Agents section.
H0, H1, H2, H3 or H4 appears in display.	Softener Hardness Level setting mode is selected.	<ul style="list-style-type: none"> This is not an error code. This code indicates the current softener hardness level. For more information, refer to the Setting the Water Softening Level section.
CL appears in display.	Control Lock is activated.	<ul style="list-style-type: none"> This is not an error code. This code indicates that the control lock is activated. Press and hold Delay Start for three seconds.

Error Codes

Problem	Possible Cause	Solutions
iE	Water inlet problem.	<ul style="list-style-type: none"> Check for a clogged, kinked or frozen water inlet hose. Check water supply.
QE	Drainage Problem.	<ul style="list-style-type: none"> Check for a clogged, kinked or frozen water drain hose.
	Air gap or disposal is clogged.	<ul style="list-style-type: none"> Clean air gap or disposal.
	Filters are clogged.	<ul style="list-style-type: none"> Clean Filters.
bE	Oversudsing caused by improper detergent, such as liquid dish soap	<ul style="list-style-type: none"> Do not use hand dishwashing liquids. Only use detergents which are designed for use in automatic dishwashers. To remove detergent residue in the tub, pour approximately 4-8 oz (100~200 ml) of milk into a shallow bowl, place it in the upper rack and then run the appliance on the Auto cycle.
	Failure to level dishwasher.	<ul style="list-style-type: none"> Make sure that the appliance is properly leveled.
RE	Water leakage	<ul style="list-style-type: none"> Turn off the water supply to the dishwasher and call a SIGNATURE KITCHEN SUITE Customer Information Center at 1-855-790-6655 (U.S.A.) or 1-888-289-2802(Canada). The dishwasher makes an alert sound for 10 seconds, and runs the drain pump intermittently. If power is turned off to the machine, the machine powers back on automatically until the AE error is resolved.
FE	Excessive Water supplied.	<ul style="list-style-type: none"> Please call an SIGNATURE KITCHEN SUITE Customer Information Center at 1-855-790-6655 (U.S.A.) 1-888-289-2802(Canada).
HE	Heater circuit failure.	
tE	Thermistor failure.	
LE	Motor trouble	
nE	Vario motor trouble	

LIMITED WARRANTY

USA

Should your SIGNATURE KITCHEN SUITE Dishwasher fail due to a defect in materials or workmanship under normal home use, during the warranty period set forth below, SIGNATURE KITCHEN SUITE will at its option repair or replace the product. This limited warranty is valid only to the original retail purchaser of the product and applies only when purchased and used within the United States, including U.S. Territories. Proof of original retail purchase is required to obtain warranty service under this limited warranty.

Warranty Period	Scope of Warranty	HOW SERVICE IS HANDLED
Three (3) years from date of original retail purchase	Labor / Parts	SIGNATURE KITCHEN SUITE will also provide, free of charge, all labor and on-site service to replace the defective part.
Five (5) years from date of original retail purchase	Main control board ¹ / Racks / Stainless Steel Door Liner / Tub	Main control board, dishwasher racks, stainless steel door liner, tub. Customer will be responsible for any labor or in-home service to replace defective parts.
Ten (10) years from date of original retail purchase	Direct Drive Motor	Direct Drive motor. Customer will be responsible for any labor or in-home service to replace defective parts.

¹ Main control board is located on the bottom right of the dishwasher when viewed from the front.

- Replacement products and parts are warranted for the remaining portion of the original warranty period or ninety (90) days, whichever is greater.
- Replacement products and parts may be new or remanufactured.

THIS WARRANTY IS IN LIEU OF ANY OTHER WARRANTY, EXPRESS OR IMPLIED, INCLUDING WITHOUT LIMITATION, ANY WARRANTY OF MERCHANTABILITY OR FITNESS FOR A PARTICULAR PURPOSE. TO THE EXTENT ANY IMPLIED WARRANTY IS REQUIRED BY LAW, IT IS LIMITED IN DURATION TO THE EXPRESS WARRANTY PERIOD ABOVE. NEITHER THE MANUFACTURER NOR ITS U.S. DISTRIBUTOR SHALL BE LIABLE FOR ANY INCIDENTAL, CONSEQUENTIAL, INDIRECT, SPECIAL, OR PUNITIVE DAMAGES OF ANY NATURE, INCLUDING WITHOUT LIMITATION, LOST REVENUES OR PROFITS, OR ANY OTHER DAMAGE WHETHER BASED IN CONTRACT, TORT, OR OTHERWISE.

Some states do not allow the exclusion or limitation of incidental or consequential damages or limitations on how long an implied warranty lasts, so the above exclusion or limitation may not apply to you. This warranty gives you specific legal rights and you may also have other rights that vary from state to state.

THIS LIMITED WARRANTY DOES NOT COVER:

- Service trips to deliver, pick up, or install or repair the product; instruction to the customer on operation of the product; repair or replacement of fuses or correction of wiring or plumbing, or correction of unauthorized repairs/installation.
- Failure of the product to perform during power failures and interrupted or inadequate electrical service.
- Damage caused by leaky or broken water pipes, frozen water pipes, restricted drain lines, inadequate or interrupted water supply or inadequate supply of air.
- Damage resulting from operating the product in a corrosive atmosphere or contrary to the instructions outlined in the product's owner's manual.
- Damage to the product caused by accidents, pests and vermin, lightning, wind, fire, floods, or acts of God.

- Damage or failure caused by unauthorized modification or alteration, or if it is used for other than the intended purpose, or any water leakage where the unit was not properly installed.
- Damage or failure caused by incorrect electrical current, voltage, or plumbing codes, commercial or industrial use, or use of accessories, components, or consumable cleaning products that are not approved by SIGNATURE KITCHEN SUITE.
- Damage caused by transportation and handling, including scratches, dents, chips, and/or other damage to the finish of your product, unless such damage results from defects in materials or workmanship and is reported within one (1) week of delivery.
- Damage or missing items to any display, open box, discounted, or refurbished product.
- Products with original serial numbers that have been removed, altered, or cannot be readily determined. Model and serial numbers, along with original retail sales receipts, are required for warranty validation.
- Increases in utility costs and additional utility expenses.
- Repairs when your product is used for other than normal and usual household use (e.g. commercial use, in offices and recreational facilities) or contrary to the instructions outlined in the product's owner's manual.
- Costs associated with removal of your product from your home for repairs.

The cost of repair or replacement under these excluded circumstances shall be borne by the consumer.

TO OBTAIN WARRANTY SERVICE AND ADDITIONAL INFORMATION

For additional product information, SIGNATURE KITCHEN SUITE website at <http://www.signaturekitchensuite.com>.

For assistance using this product or to schedule service, contact SIGNATURE KITCHEN SUITE at 1-855-790-6655.

For further assistance, write: SIGNATURE KITCHEN SUITE, 201 James Record Road, Huntsville, Alabama 35813

CANADA

WARRANTY: Should your SIGNATURE KITCHEN SUITE Dishwasher (“Product”) fail due to a defect in material or workmanship under normal home use during the warranty period set forth below, SIGNATURE KITCHEN SUITE Canada will at its option repair or replace the product upon receipt of proof of original retail purchase. This warranty is valid only to the original retail purchaser of the product and applies only to a product distributed in Canada by SIGNATURE KITCHEN SUITE Canada or an authorized Canadian distributor thereof. The warranty only applies to Products located and used within Canada. Coverage for “in Home” repairs, for products in-warranty, will be provided if the Product is within a 150 km radius from the nearest authorized service center (ASC), as determined by SIGNATURE KITCHEN SUITE Canada. If your Product is located outside a 150 km radius from a ASC, as determined by SIGNATURE KITCHEN SUITE Canada, it will be your responsibility to bring the Product, at your sole expense, to the ASC for in-warranty repair.

WARRANTY PERIOD: (Note: If the original date of purchase can not be verified, the warranty will begin sixty (60) days from the date of manufacture.)		
Dishwasher	Extended Component Warranty (Parts Only) (Consumer will be charged for Labor after Three (3) years from the date of purchase.)	
Three (3) years from the date of original retail purchase	Five (5) years from the date of original retail purchase	Ten (10) years from the date of original retail purchase
Labor / Parts (internal/functional parts only)	Main control board ¹ , Rack, Stainless Steel Door Liner, Tub	DD Motor

1 Main control board is located on the right bottom of the Dishwasher when viewed from the front.

- Replacement products and parts are warranted for the remaining portion of the original warranty period or ninety (90) days, whichever is greater.
- Replacement products and parts may be new or remanufactured.
- SIGNATURE KITCHEN SUITE Authorized Service Center warranties their repair work for thirty (30) days.

SIGNATURE KITCHEN SUITE CANADA'S SOLE LIABILITY IS LIMITED TO THE WARRANTY SET OUT ABOVE. EXCEPT AS EXPRESSLY PROVIDED ABOVE, SIGNATURE KITCHEN SUITE CANADA MAKES NO AND HEREBY DISCLAIMS ALL OTHER WARRANTIES AND CONDITIONS RESPECTING THE PRODUCT, WHETHER EXPRESS OR IMPLIED, INCLUDING, BUT NOT LIMITED TO, ANY IMPLIED WARRANTY OR CONDITION OF MERCHANTABILITY OR FITNESS FOR A PARTICULAR PURPOSE, AND NO REPRESENTATIONS SHALL BE BINDING ON SIGNATURE KITCHEN SUITE CANADA. SIGNATURE KITCHEN SUITE CANADA DOES NOT AUTHORIZE ANY PERSON TO CREATE OR ASSUME FOR IT ANY OTHER WARRANTY OBLIGATION OR LIABILITY IN CONNECTION WITH THE PRODUCT. TO THE EXTENT THAT ANY WARRANTY OR CONDITION IS IMPLIED BY LAW, IT IS LIMITED TO THE EXPRESS WARRANTY PERIOD ABOVE. SIGNATURE KITCHEN SUITE CANADA, THE MANUFACTURER OR DISTRIBUTOR SHALL NOT BE LIABLE FOR ANY INCIDENTAL, CONSEQUENTIAL, SPECIAL, DIRECT OR INDIRECT DAMAGES, LOSS OF GOODWILL, LOST PROFITS, PUNITIVE OR EXEMPLARY DAMAGES OR ANY OTHER DAMAGE, WHETHER ARISING DIRECTLY OR INDIRECTLY FROM ANY CONTRACTUAL BREACH, FUNDAMENTAL OR OTHERWISE, OR FROM ANY ACTS OR OMISSIONS, TORT, OR OTHERWISE.

This warranty gives you specific legal rights. You may have other rights which may vary from province to province depending on applicable provincial laws. Any term of this warranty that negates or varies any implied condition or warranty under provincial law is severable where it conflicts with provincial law without affecting the remainder of this warranty's terms.

THIS LIMITED WARRANTY DOES NOT COVER:



- Service trips to deliver, pick up, or install the product; instructing a customer on operation of the product; repair or replacement of fuses or correction of wiring or plumbing, or correction of unauthorized repairs/installation.
- Failure of the product to perform during power failures and interruptions or inadequate electrical service.
- Damage caused by leaky or broken water pipes, frozen water pipes, restricted drain lines, inadequate or interrupted water supply or inadequate supply of air.
- Damage resulting from operating the Product in a corrosive atmosphere or contrary to the instructions outlined in the Product owner's manual.
- Damage to the Product caused by accidents, pests and vermin, lightning, wind, fire, floods, or acts of God.
- Damage or product failure caused by unauthorized modification or alteration, or use for other than its intended purpose, or resulting from any water leakage due to improper installation.
- Damage or Product failure caused by incorrect electrical current, voltage, or plumbing codes, commercial or industrial use, or use of accessories, components, or cleaning products that are not approved by SIGNATURE KITCHEN SUITE Canada.
- Damage caused by transportation and handling, including scratches, dents, chips, and/or other damage to the finish of your product, unless such damage results from defects in materials or workmanship and is reported within one (1) week of delivery.
- Damage or missing items to any display, open box, discounted, or refurbished Product.
- Products with original serial numbers that have been removed, altered, or cannot be readily determined. Model and Serial numbers, along with original retail sales receipt, are required for warranty validation.
- Increases in utility costs and additional utility expenses.
- Replacement of light bulbs, filters, or any consumable parts.
- Repairs when your Product is used in other than normal and usual household use (including, without limitation, commercial use, in offices or recreational facilities) or contrary to the instructions outlined in the Product owner's manual.
- Costs associated with removal of the Product from your home for repairs.
- The removal and reinstallation of the Product if it is installed in an inaccessible location or is not installed in accordance with published installation instructions, including the Product owner's and installation manuals.
- Accessories to the Product such as door bins, drawers, handles, shelves, etc.. Also excluded are parts besides those that were originally included with the Product.
- Damage resulting from the misuse, abuse, improper installation, repair, or maintenance of the Product. Improper repair includes use of parts not approved or specified by SIGNATURE KITCHEN SUITE Canada.

All costs associated with the above excluded circumstances shall be borne by the consumer.

For complete warranty details and customer assistance, please call or visit our website:

Call 1-888-289-2802 (7 A.M to 12 A.M, 365 days a year) and select the appropriate option from the menu, or Visit our website at <http://www.signaturekitchensuite.com>

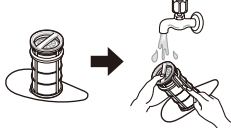
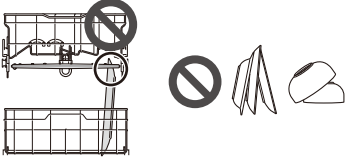
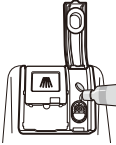
Warranty Exceptions (U.S. and Canada)

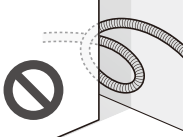
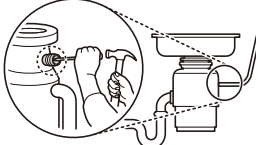
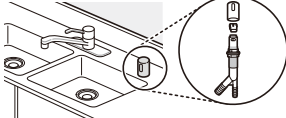
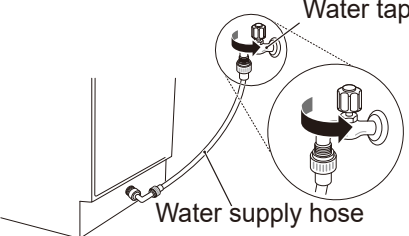
<p>Poor wash results caused by debris remaining in the filter.</p>		<ul style="list-style-type: none"> • Clean the filter regularly.
<p>Poor wash results caused by improper loading or over stacking: wash arm won't rotate or soap dispenser is held closed.</p>		<ul style="list-style-type: none"> • Make certain that no dishes or utensils are in the path of the spray arms. • Do not place one dish on top of another.
<p>Poor drying results caused by lack of rinse aid.</p>		<ul style="list-style-type: none"> • Use rinse aid or combination detergent.
<p>Water is not supplied because the water tap is not turned on. IE error</p>		<ul style="list-style-type: none"> • Check and turn on the water tap.
<p>Water is not supplied because the inlet hose is kinked. IE error</p>		<ul style="list-style-type: none"> • Reinstall the inlet hose.
<p>Not draining because drain hose is kinked. OE error</p>		<ul style="list-style-type: none"> • Reinstall the drain hose.
<p>The knockout plug in the garbage disposal is not removed. OE error</p>		<ul style="list-style-type: none"> • Remove the plug on the disposal.
<p>The disposal or air gap is blocked by debris. OE error</p>		<ul style="list-style-type: none"> • Clean the disposal or the air gap.
<p>Inlet valve and drain hose connection problem caused by improper installation. External leakage</p>		<ul style="list-style-type: none"> • Reinstall the hose.

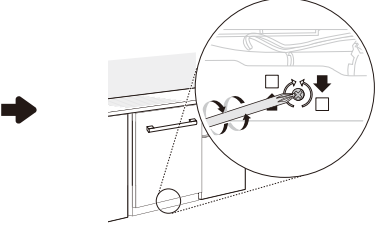
<p>Door movement or closing compromised by incorrect leveling.</p>		<ul style="list-style-type: none"> • Adjust the lower front leveling legs to the required height.
<p>No power due to loose connection of power cord or electrical outlet problem.</p>		<ul style="list-style-type: none"> • Reconnect the power cord or repair the electrical outlet.
<p>Pick-up, electrical wiring, plumbing. Installation</p>		<ul style="list-style-type: none"> • You will be charged for the installation.

