

# 61" HATTIE

## ACRYLIC SLIPPER TUB - LION PAW FEET

SKU: 916558

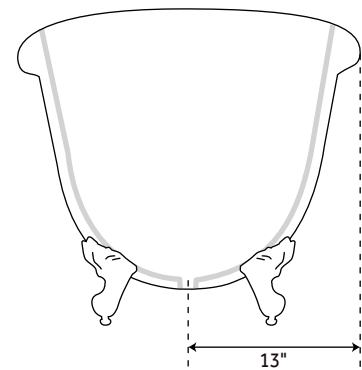
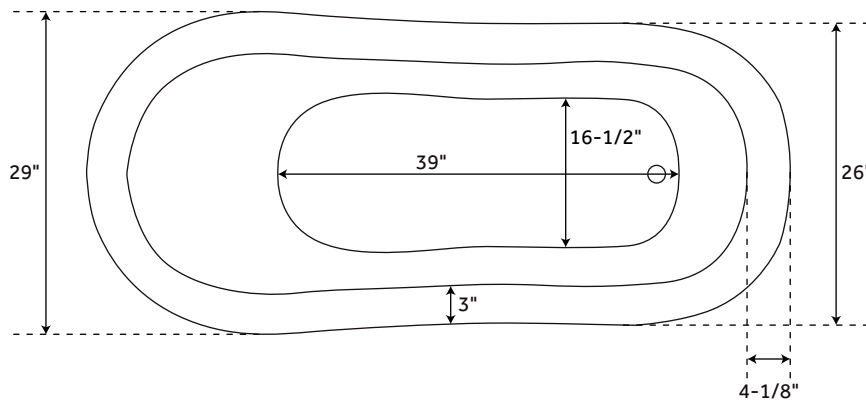
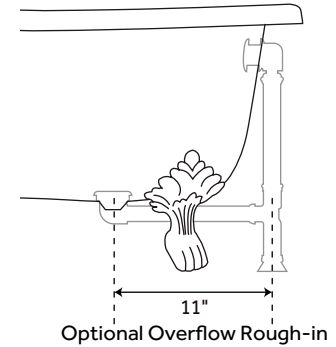
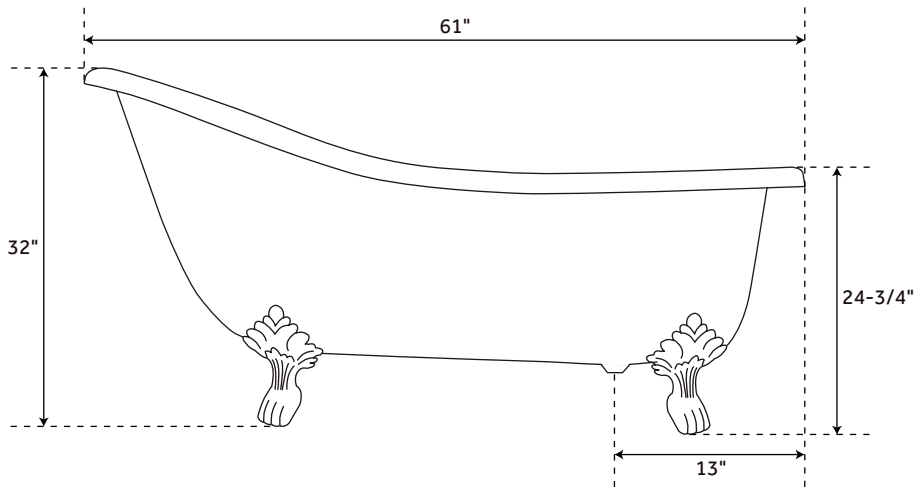

### FEATURES

Product Finish: White  
Features: Custom Painting Available  
Overflow Hole: Optional  
Material: Acrylic  
Length: 61"  
Width: 29"  
Height: 32"  
Water Depth to Rim: 17-1/8"  
Water Depth Without/With Overflow:  
17-1/8"/13-1/2"  
Feet Type: Lion Paw  
Feet Material: Cast Aluminum  
Drain Included: Optional  
Drain Placement: End  
Faucet Included: No  
Water Capacity Without/With Overflow  
(Gallons): 47/38  
Built-In Adjusters: Yes  
Tub Weight Uncrated (lbs): 85  
Tub Weight Crated (lbs): 310

### SIGNATURE HARDWARE LIFETIME WARRANTY

See website for warranty information



All dimensions and specifications are nominal and may vary. Use actual products for accuracy in critical situations.

REVISED 10/21/2019

# 67" HATTIE

## ACRYLIC SLIPPER TUB - LION PAW FEET

SKU: 916558

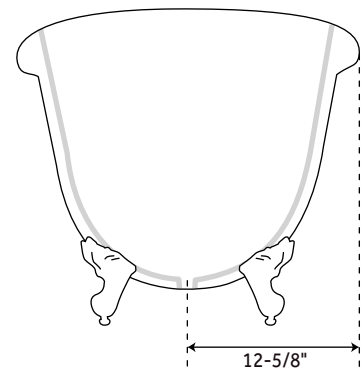
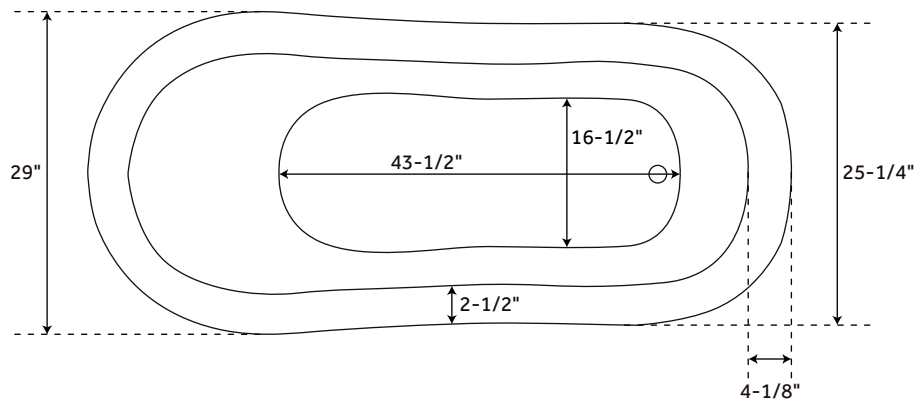
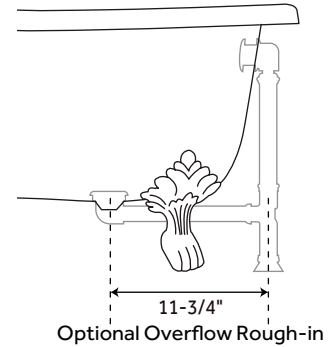
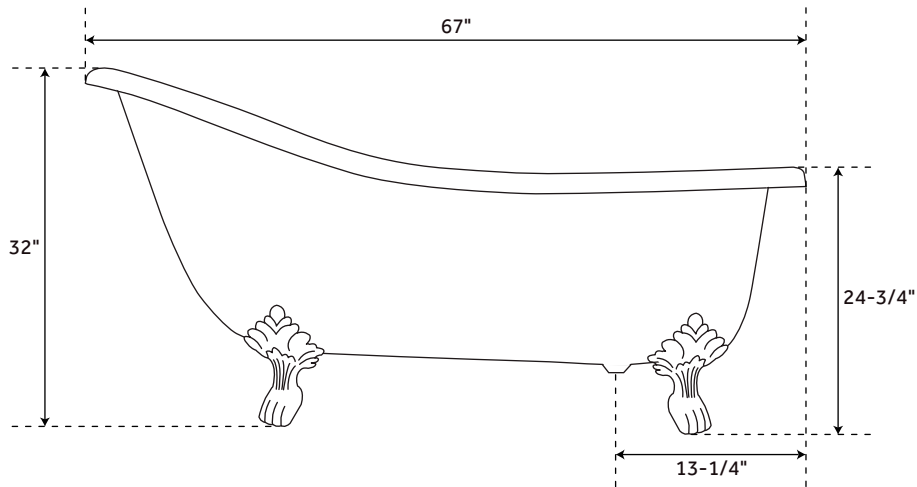

### FEATURES

- Product Finish: White
- Features: Custom Painting Available
- Overflow Hole: Optional
- Material: Acrylic
- Length: 67"
- Width: 29"
- Height: 32"
- Water Depth to Rim: 17-1/8"
- Water Depth Without/With Overflow: 17-1/4"/13-1/2"
- Feet Type: Lion Paw
- Feet Material: Cast Aluminum
- Drain Included: Optional
- Drain Placement: End
- Faucet Included: No
- Water Capacity Without/With Overflow (Gallons): 52/41
- Built-In Adjusters: Yes
- Tub Weight Uncrated (lbs): 90
- Tub Weight Crated (lbs): 315

### SIGNATURE HARDWARE LIFETIME WARRANTY

See website for warranty information



All dimensions and specifications are nominal and may vary. Use actual products for accuracy in critical situations.

REVISED 10/21/2019