

NOTES:

1. DIMENSIONS IN BRACKETS [] ARE MILLIMETERS, FOR REFERENCE ONLY.
2. GRAIN DIRECTION PER ASME Y14.36M-1996 FOR SS SATIN FINISHES ONLY.

CUSTOMER SPECIFICATION DWG

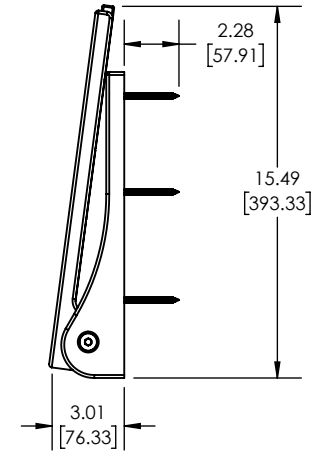
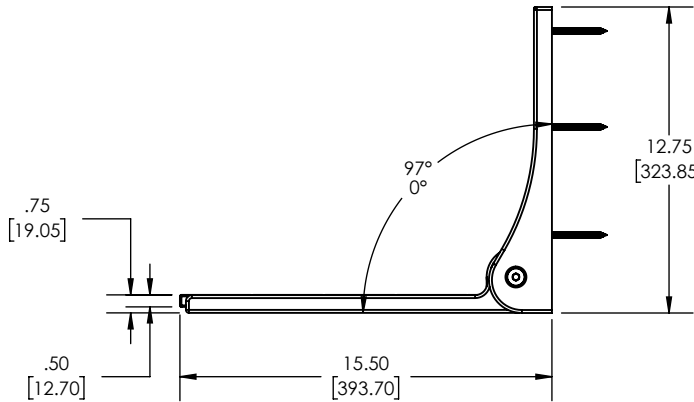
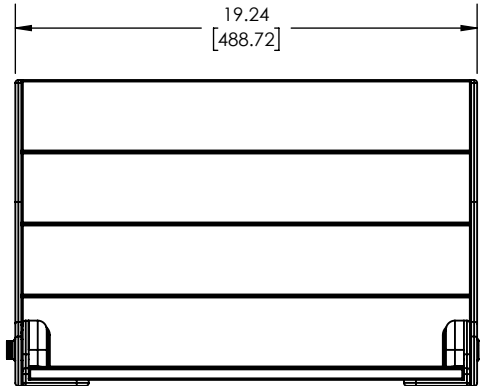
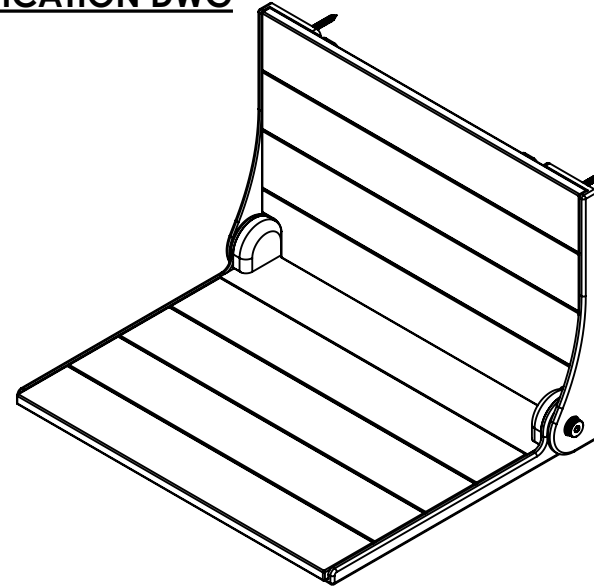
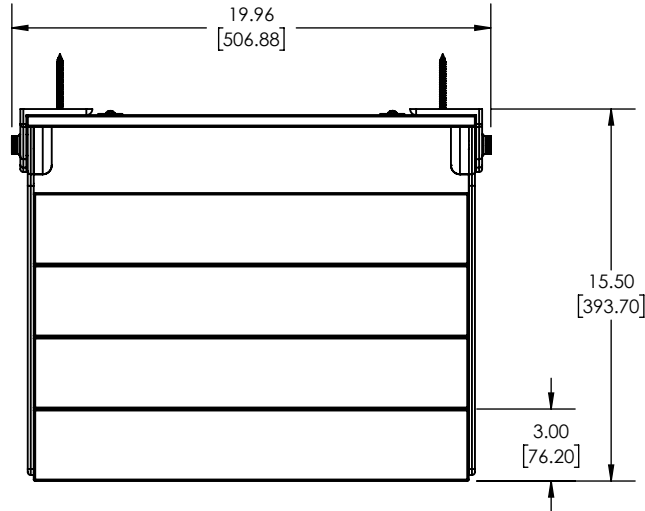

-HARDWARE PACKAGE INCLUDES:
1. #14 X 2.5 PHIL FLAT "A" 18-8 SS PN (S-4500-120456 QTY 6)

Proprietary & Confidential

This drawing and the information contained herein is the property of Seachrome Corporation and shall not be reproduced, copied, or disclosed in whole or in part, or used in manufacturing, or for any other purpose without the written permission of Seachrome Corporation.

INTERPRET GEOMETRIC TOLERANCING PER: ASME Y14.5-2009
UNLESS OTHERWISE SPECIFIED: DIMENSIONS ARE IN INCHES [MM]
TOLERANCES: DECIMALS
FRACTIONAL ±1/64 .X ±0.1
ANGLES ± 1° .XX ±0.02

DRAWN E.BARBER 09/20/21
ENG APPR. J. AMOZOC 09/20/21

SEACHROME

1906 EAST DOMINGUEZ
LONG BEACH, CA 90810
(310) 427-8010

CORPORATION

TITLE:
SILHOUETTE SHOWER SEAT, TEAK WOOD

DWG. NO.	SHAF-185155-TW	REV A
SIZE	A DO NOT SCALE DRAWING	SCALE: 1:8
		SHEET 1