

# SEACHROME

Seachrome Corporation  
1906 East Dominguez Street  
Long Beach, California 90810  
Phone: (800) 955-2476  
Fax: (800) 444-3380

Description:

SSL2-320225-PWS  
32" x 22-1/2" SHOWER SEAT  
Left Hand with Swing Down Leg

Customer:

Customer Part #

05-14-2015

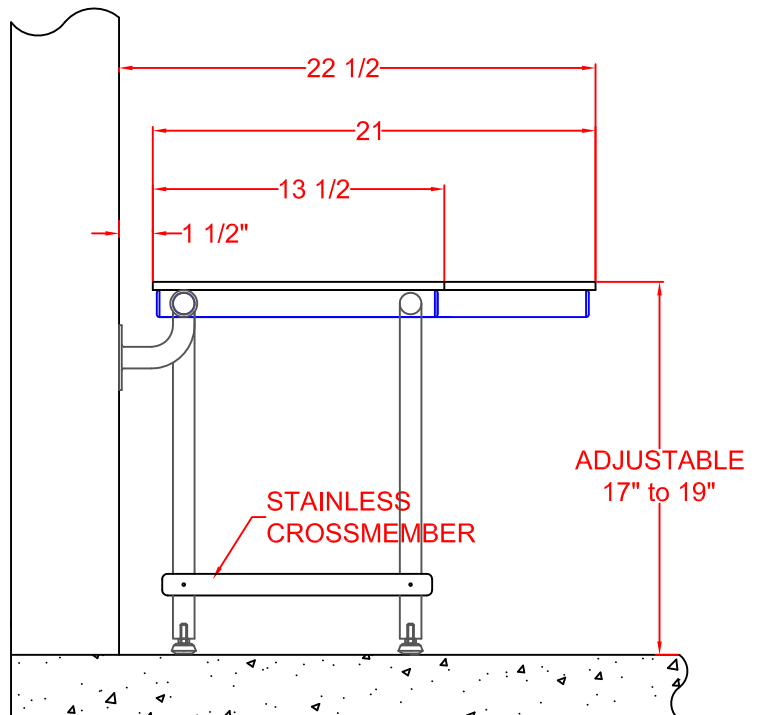
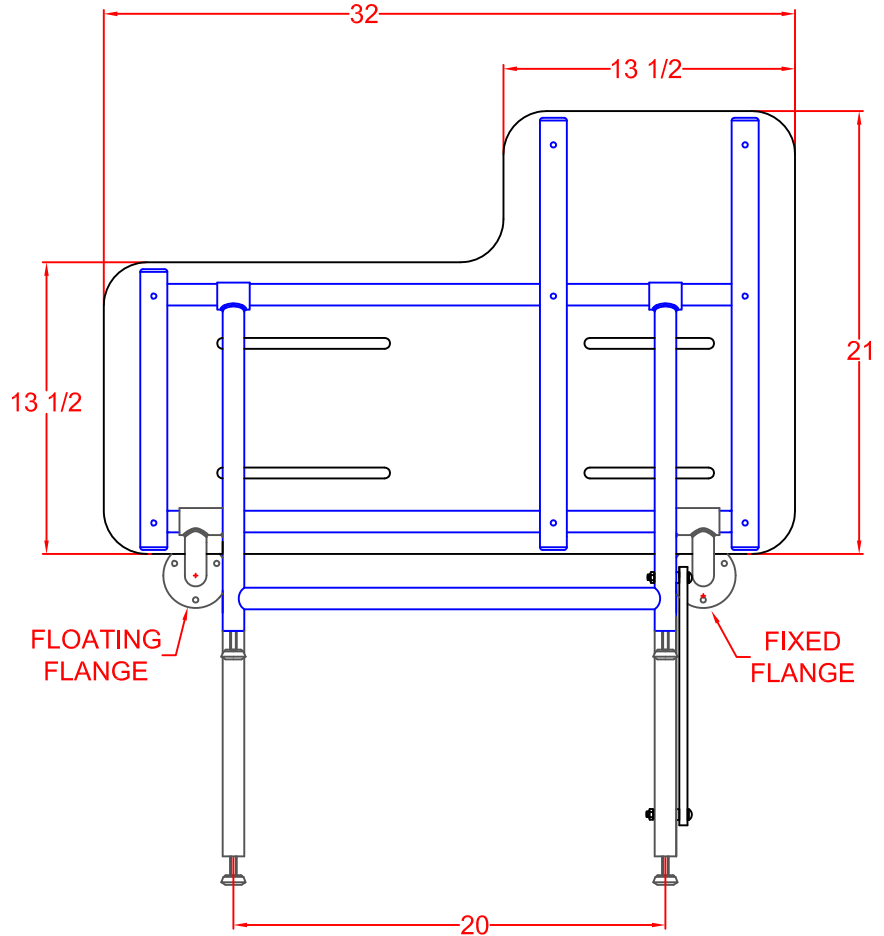
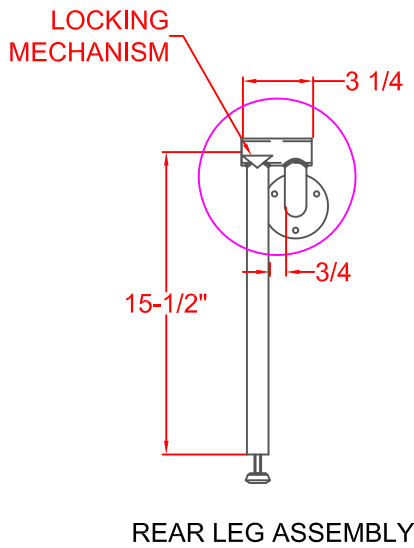

This drawing and the information contained herein is proprietary to Seachrome Corp. and shall not be reproduced, copied or disclosed in whole, or part, or used for manufacturing or for any other purpose without the written permission of Seachrome Corporation.

# SEACHROME

Seachrome Corporation  
1906 East Dominguez Street  
Long Beach, California 90810  
Phone: (800) 955-2476  
Fax: (800) 444-3380

Description:

SSL2-320225-PWS  
32" x 22-1/2" SHOWER SEAT  
Left Hand with Swing Down Leg

Customer:

Customer Part #

05-14-2015

## SHOWER SEAT MODEL #SSL2-320225-PWS Left Hand with Swing Down Leg

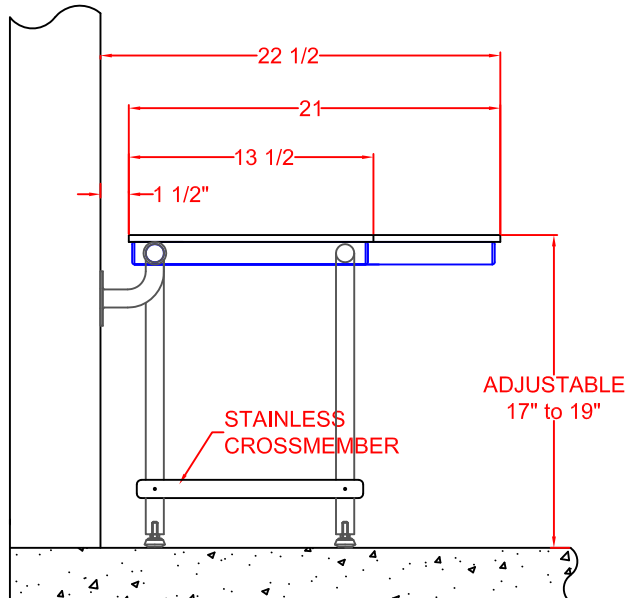
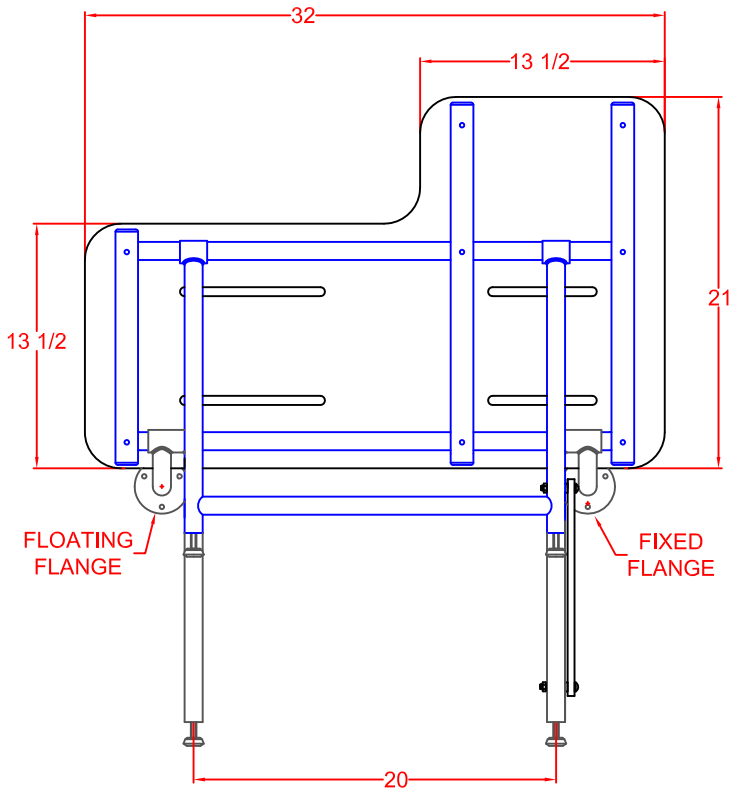

### OPERATION:

Seat is automatically held in a raised position by a stainless cross member attached to the front and rear support legs. When seat is lowered into its down position the Swing Down Leg automatically aligns the front and rear support legs with the help of the stainless cross member.

### ARCHITECTURAL SPECIFICATIONS:

Model #SSL2-320225-PWS Folding Shower Seat from Seachrome Corp., Long Beach, California 90810. Phone: (800) 955-2476. Frame: Type 304 (18-8) S.S. tube, 1-1/4" (32mm) x 18ga. (1.2mm) sq. main frame with 1" (25mm) x 18ga. (1.2mm) rd. cross members. Leg: "H" - shaped yoke of type 304 (18-8) S.S. tubing, 1" (25mm) x 18ga. (1.2mm) rd. tubing, Heliarc welded to 1-1/4" (32mm) rd. x 12ga. (2.7mm) frame hinge. The Swing Down Legs automatically level when the seat is lowered to a horizontal sitting position. The seat automatically locks itself when swung into its "up" position with the use of the stainless cross member.

### MATERIALS:

FRAME: Type 304 (18-8) S.S. tubing, 1-1/4" (32mm) x 18ga. (1.2mm) sq. main frame with 1" (25mm) x 18ga. (1.2mm) rd. cross-members.

WALL FLANGES (2): Type 304 (18-8) S.S., 10ga. (3.4mm) x 3" (76mm) dia. heliarc welded to 1" (25mm) rd. x 18ga. (1.2mm) 90 degree leg supports, and to 1-1/4" (32mm) rd. x 12ga. (2.7mm) frame hinge couplings. Three mounting holes in each flange.

SWING DOWN LEG: "H" shaped yoke of type 304 (18-8) S.S. 1" Dia. (25mm) x 18ga. (1.2mm) rd. tubing, heliarc welded to 1-1/4" (32mm) rd. x 12ga. (2.7mm) frame hinge couplings.

### SEAT CHOICES:(Designate when ordering)

- NW or NA - White (NW) or Almond (NA) Naugahyde covering 2" (51mm) foam mounted on 1/2" (13mm) marine plywood.
- PW or PT - White (PW) or Teak (PT) Finish Phenolic 1/2" (13mm) x 3" (76mm) slats bolted to frame with S.S. screws.
- HW - White High Density Polyethelene (HDPE) 1/2" (13mm) thick, bolted to frame with S.S. screws.

### INSTALLATION:

All Shower Seats must only be installed using suitable fasteners and sufficient in-wall backing materials. ADA mounting height for lowered seat is 17" (432mm) to 19" (482mm).