

SCHONBEK
*Signature*TM

CALLIOPE
S5710-__ __O

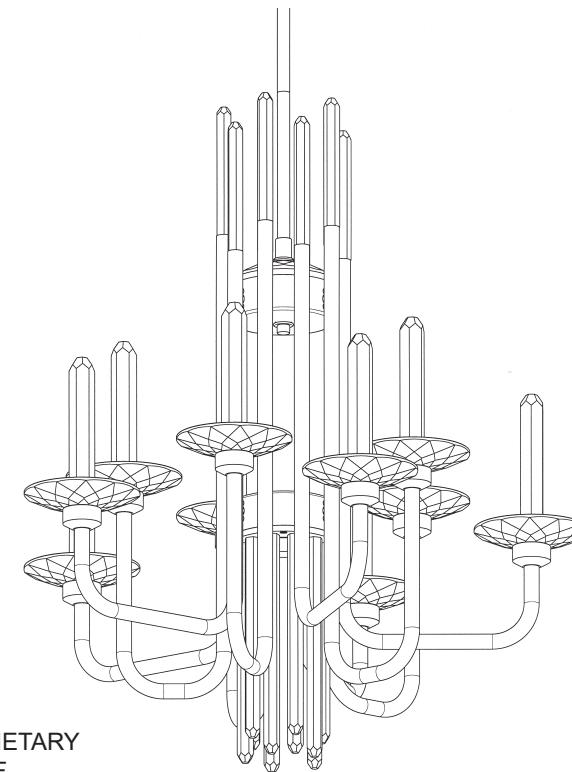

THIS DESIGN IS THE PROPRIETARY
TRADE DRESS/TRADEMARK OF
W SCHONBEK LLC.

SCHONBEK
*Signature*TM

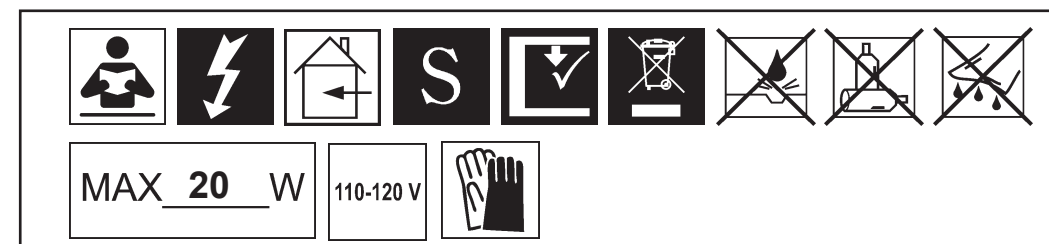

4

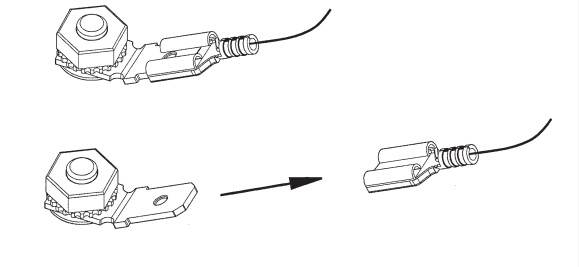

6

NOTE:
LOOSEN 1 SCREW, ON
EACH SIDE OF MOUNTING
WASHER, AND REMOVE
THE OTHER (SET ASIDE)

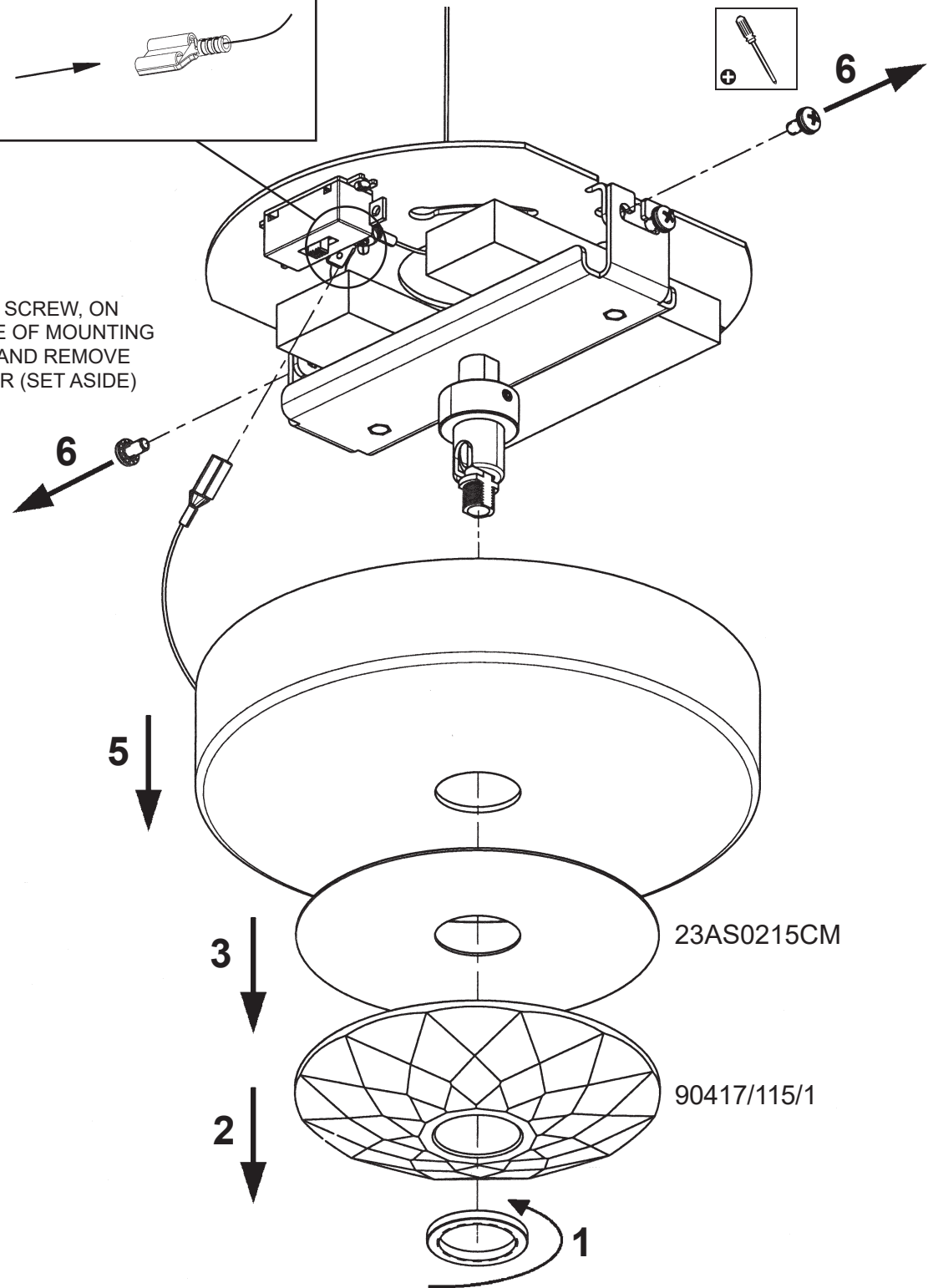

5 X  : SWL2310-ORING

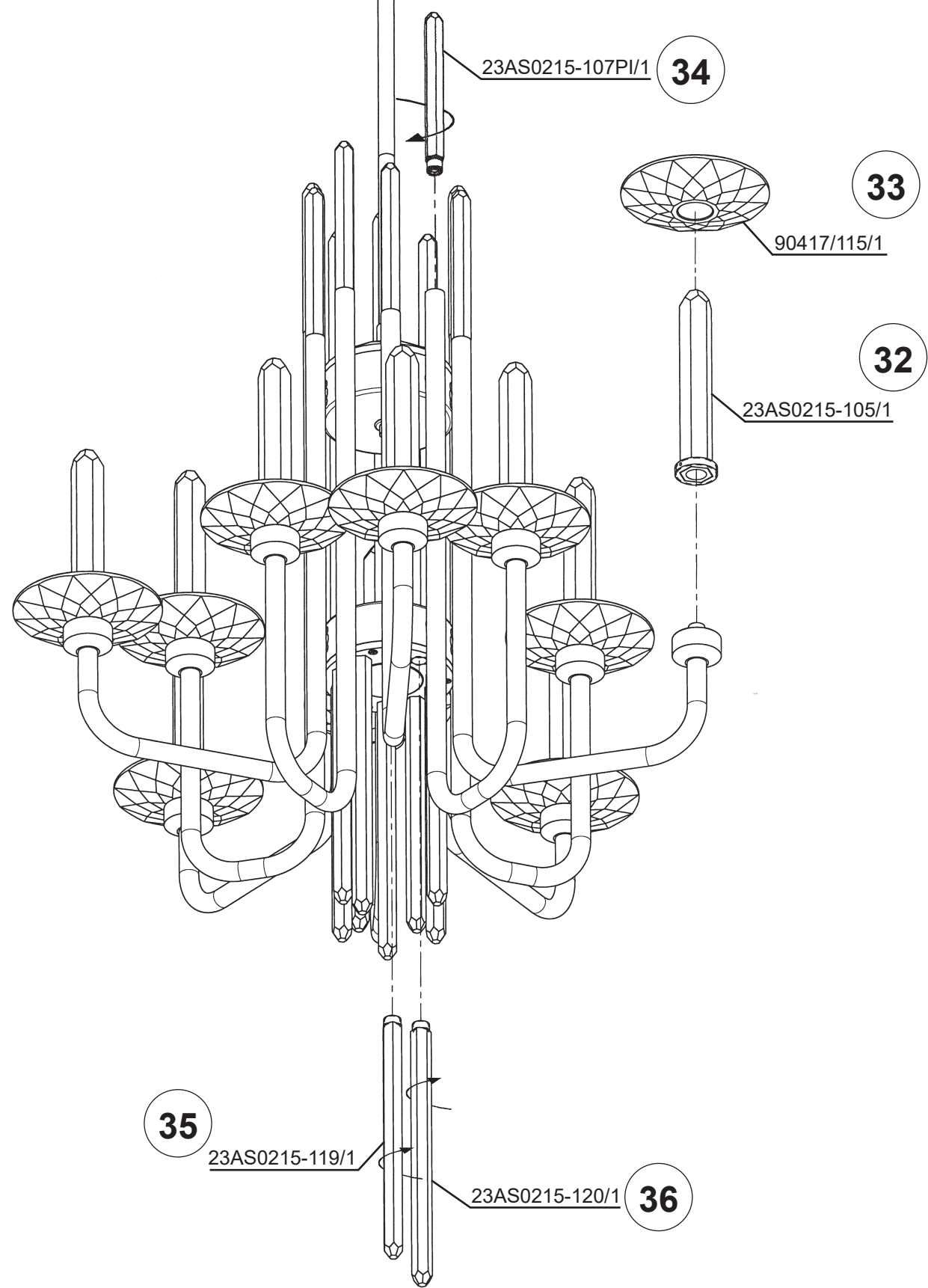

NOTE: ALTERNATE INSTALLING
23AS0215-121/1 AND 23AS0215-123/1

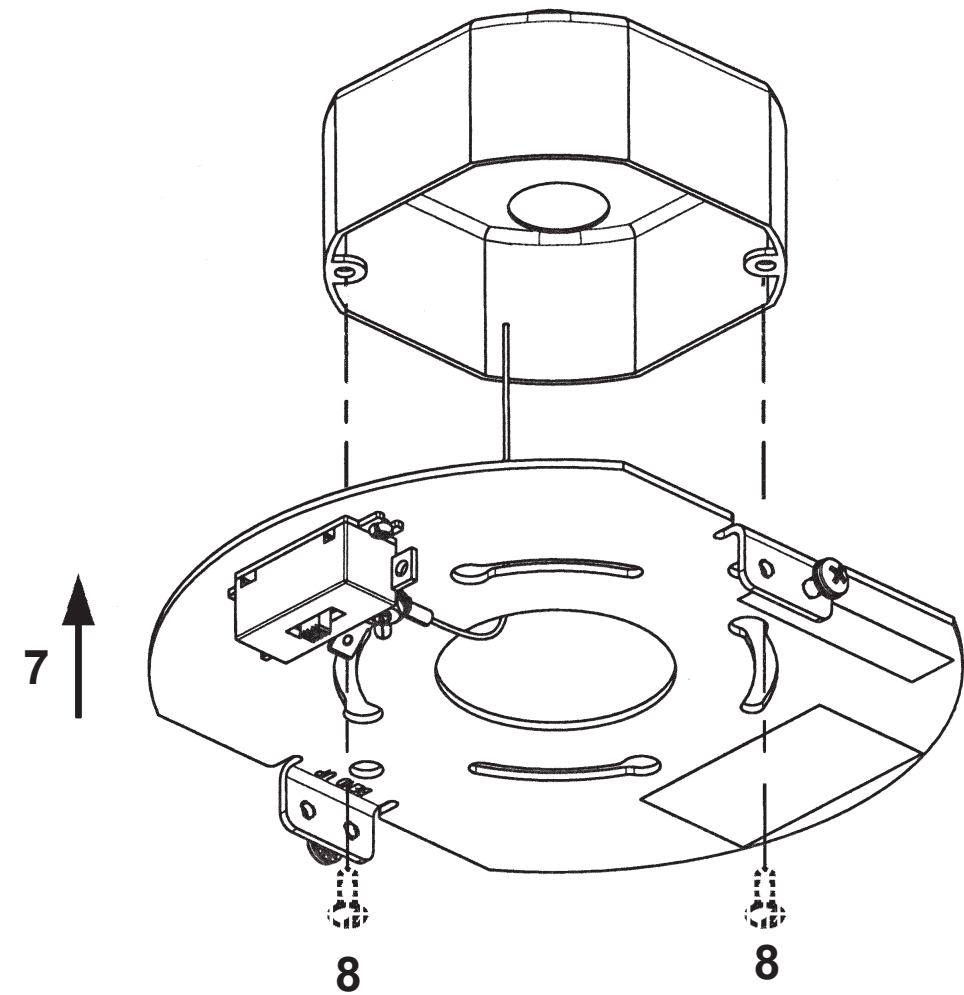
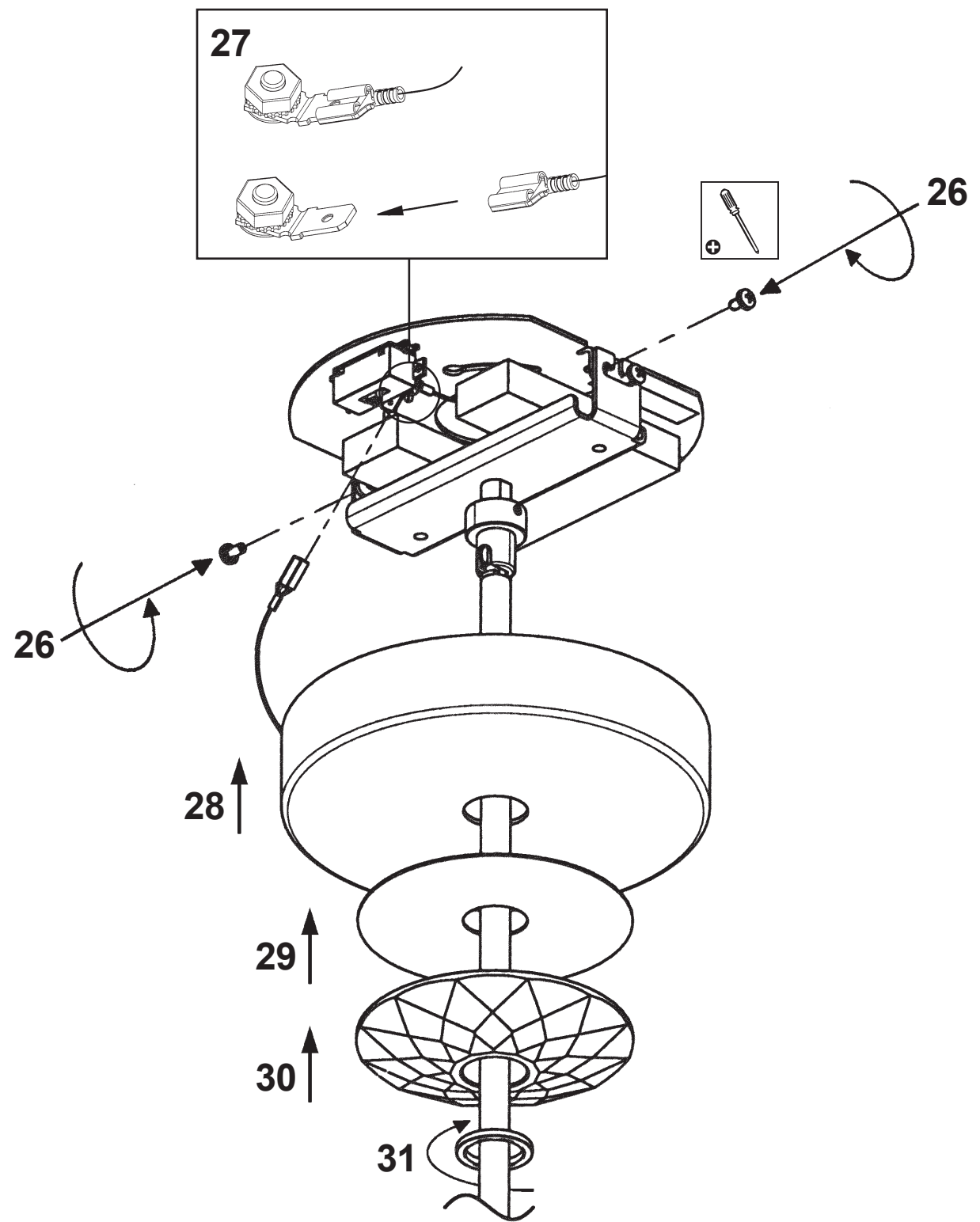

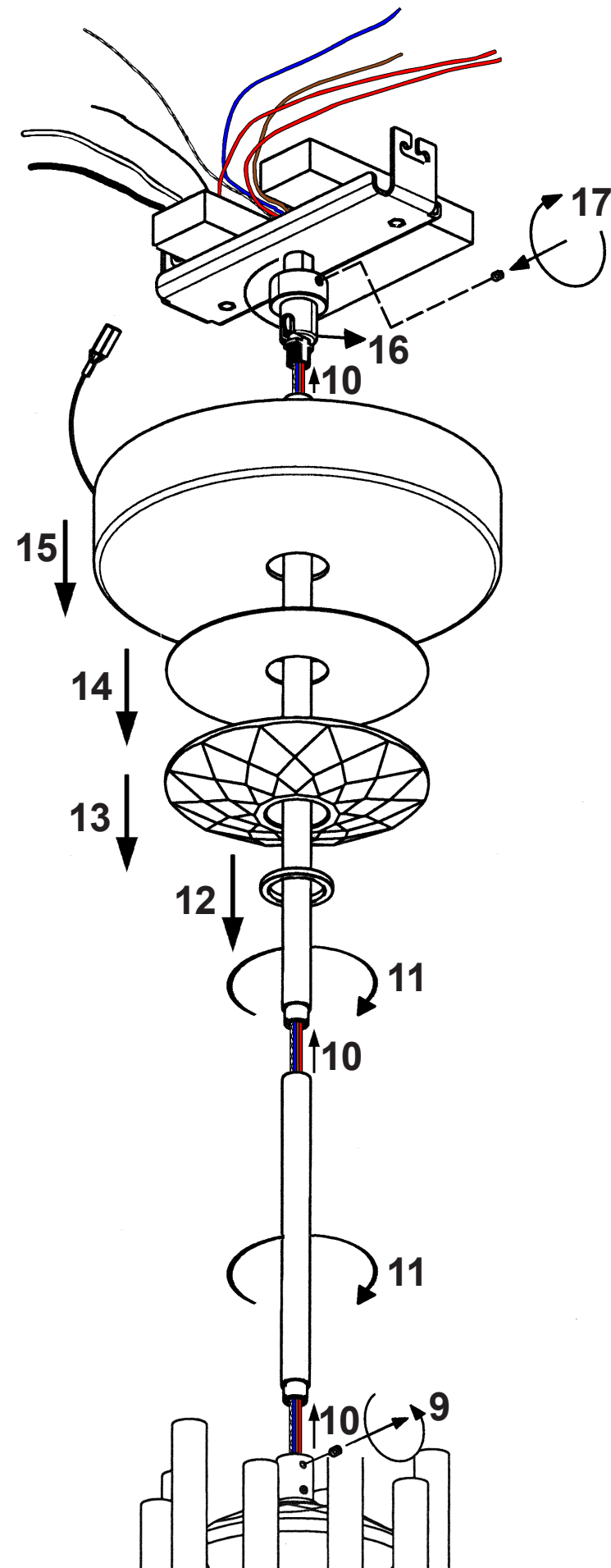

19 SELECT DESIRED LED
 COLOR TEMPERATURE
**NOTE: FIXTURE POWER MUST
 BE OFF BEFORE CHANGING
 THE CCT SETTING.**

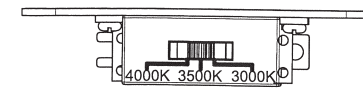

3000K = WARM
 3500K = WARM/NATURAL
 4000K = NATURAL

