

Instructions for electrician
STEPS 2 - 6

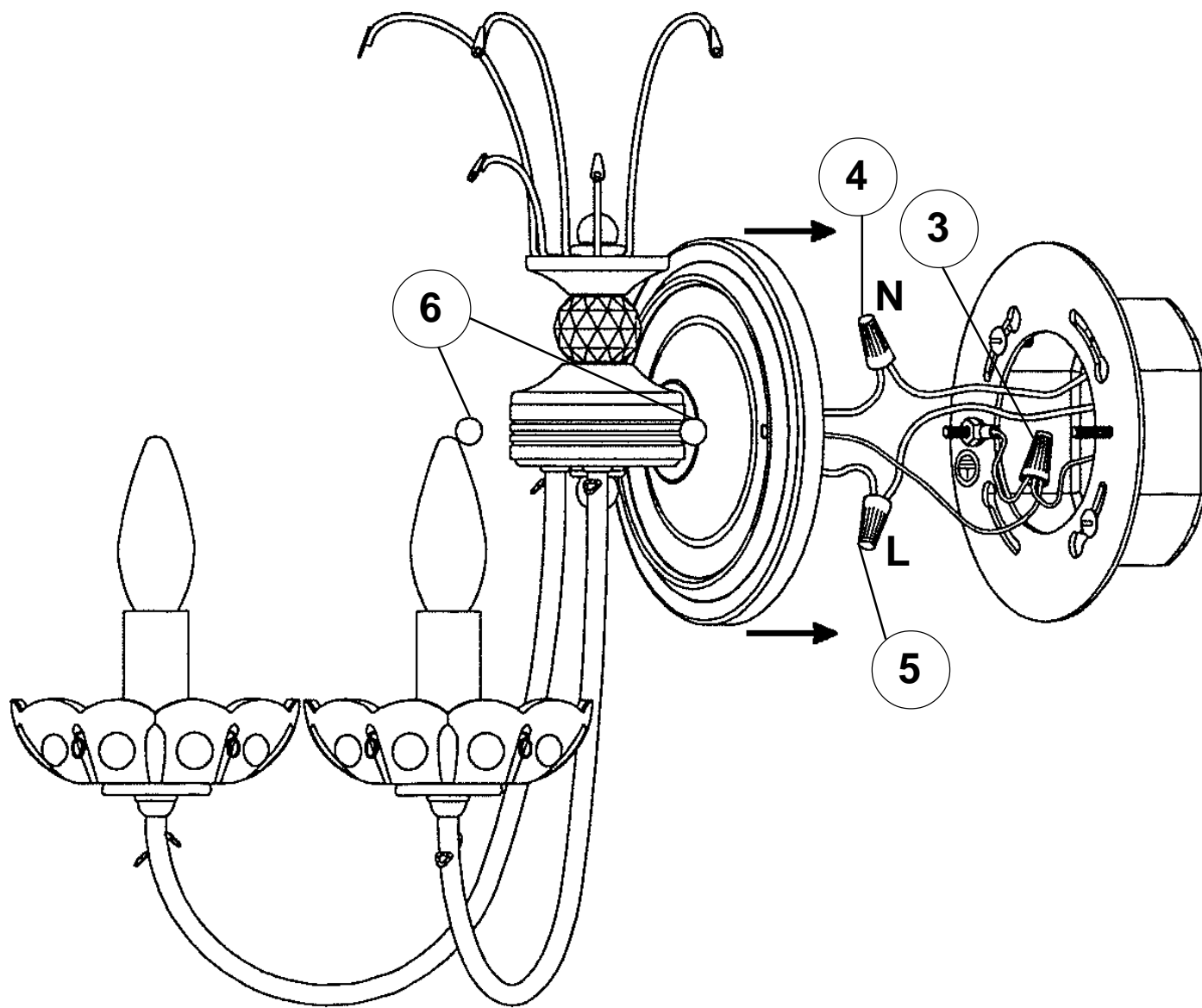

LUCIA
LU0004N-____H TRIM DIAGRAM
(Finish Option)

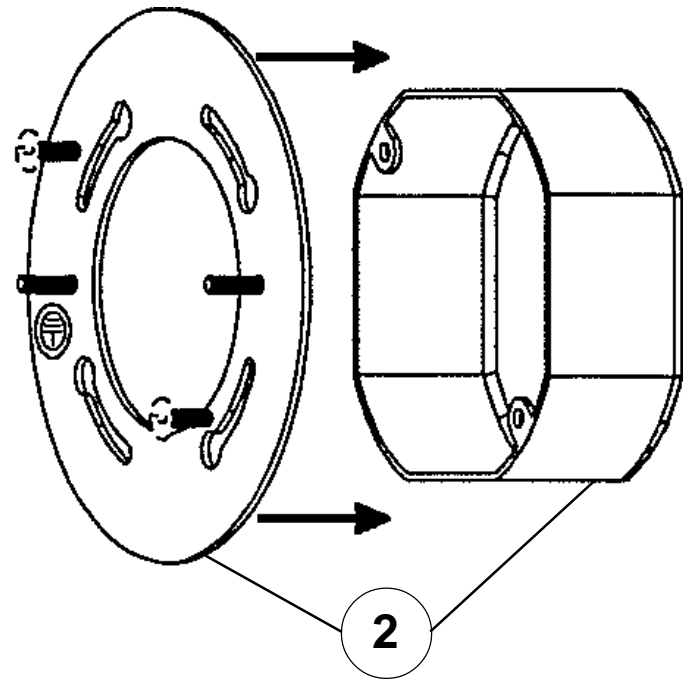
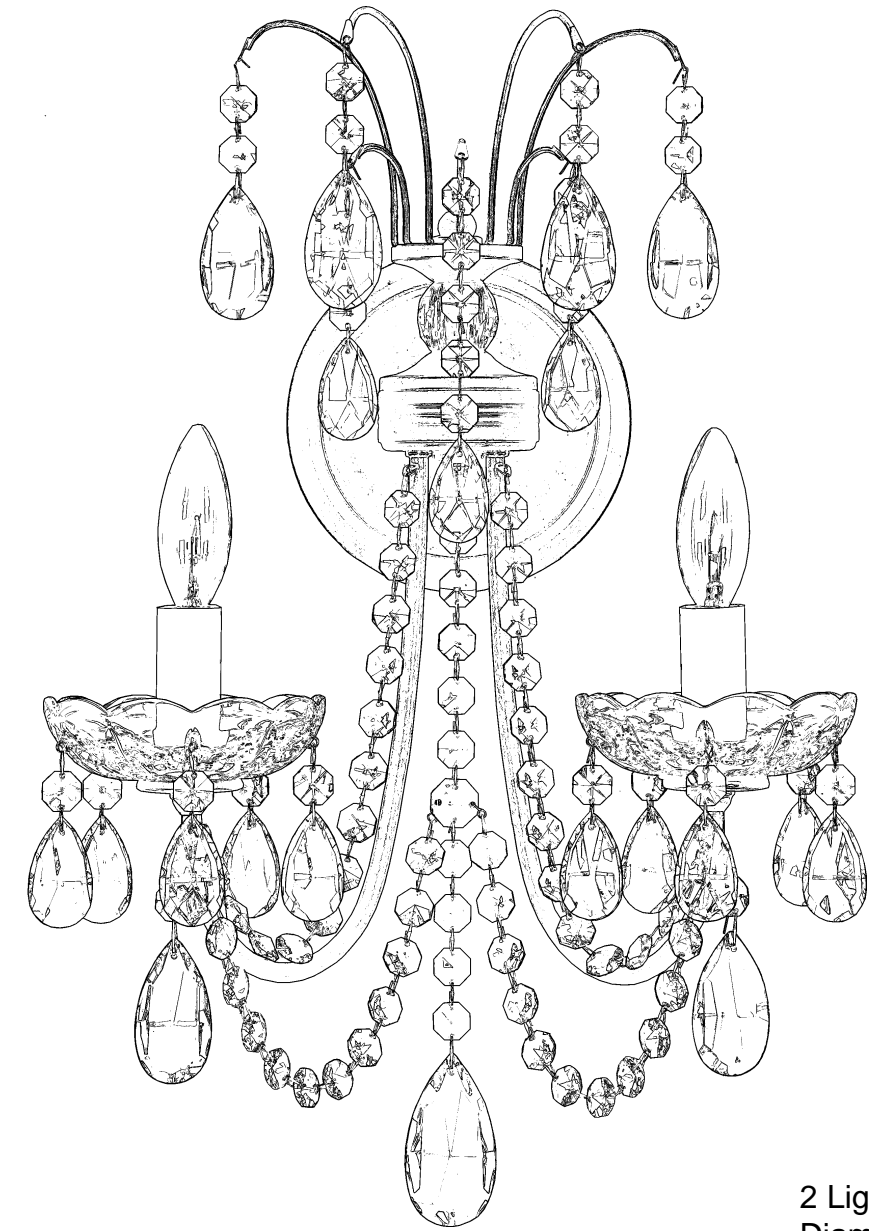

2 Lights
Diameter: 12"
Body Length: 18"
Extension: 9"
Hanging Weight: 3lbs.

THIS DESIGN IS THE PROPRIETARY
TRADE DRESS/TRADemark OF
SCHONBEK WORLDWIDE LIGHTING INC.

SCHONBEK®



MAX 60 W

1

IMPORTANT

Person who opens carton should record the following information for future service.

CODE # _____ Four-digit number on outside of carton.
PACKER # _____ See crystal package label.
ORDER # _____ See crystal package label.



Instructions for crystal trimming STEPS 7 - 15

7

You will need 2 - B10
25 Watts Recommended
60 Watts Max

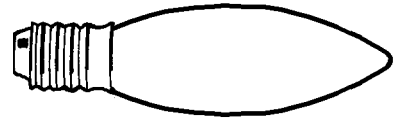

Install bulbs and be
sure to test fixture
BEFORE trimming.

