

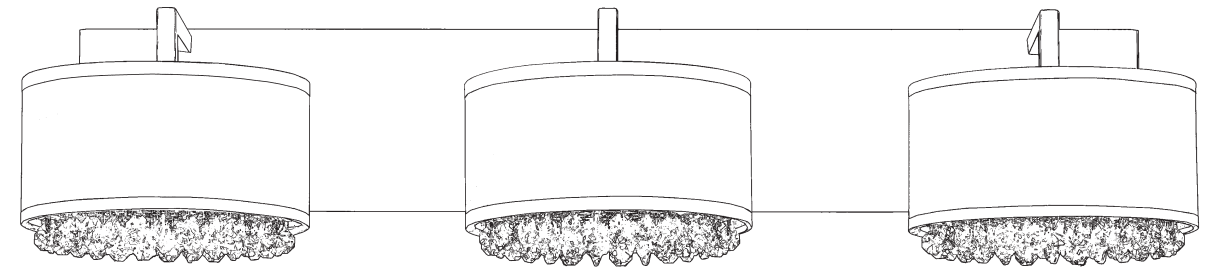

**SCHONBEK®**

**ECLYPTIX**  
**EC0336N- \_\_\_\_ \_ A \_\_\_\_**



**T**HIS DESIGN IS THE PROPRIETARY  
TRADE DRESS/TRADEMARK OF  
SWAROVSKI LIGHTING, LTD.

6 Lights  
Length: 28"  
Height: 6"  
Extension: 8"  
Hanging Weight: 10lbs.



**SCHONBEK®**

MAX <u>40</u> W		110-120 V						

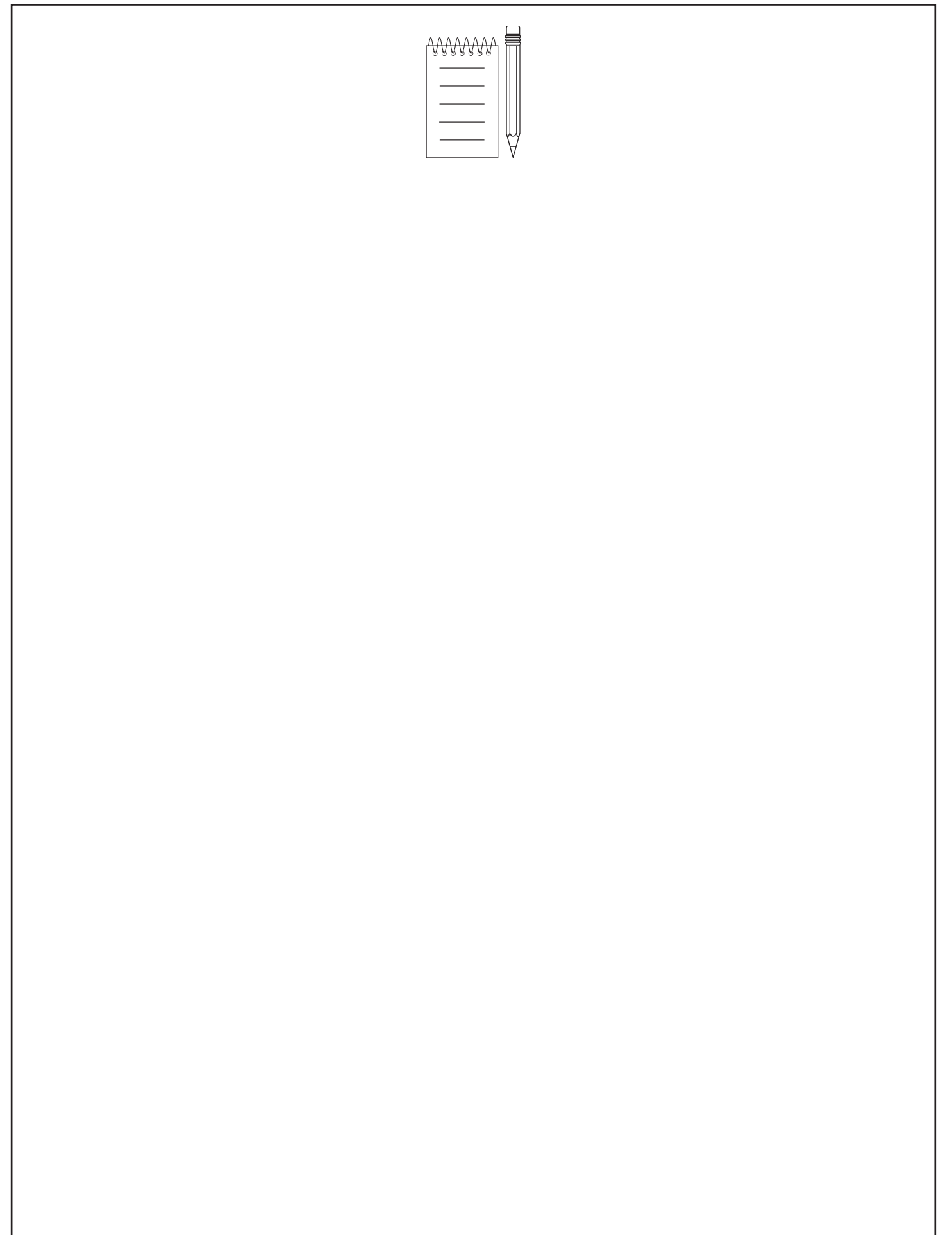
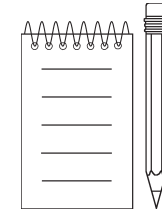
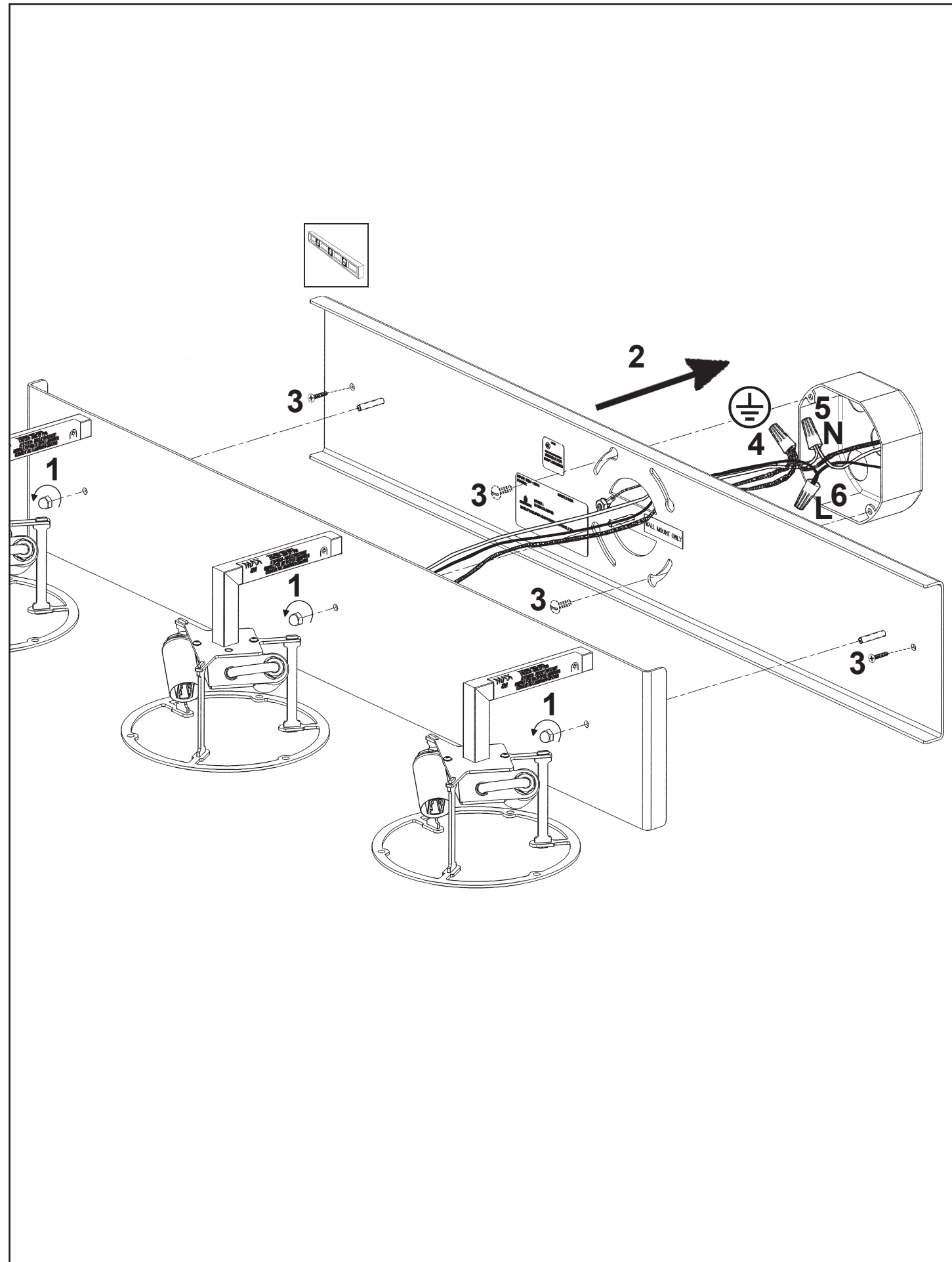

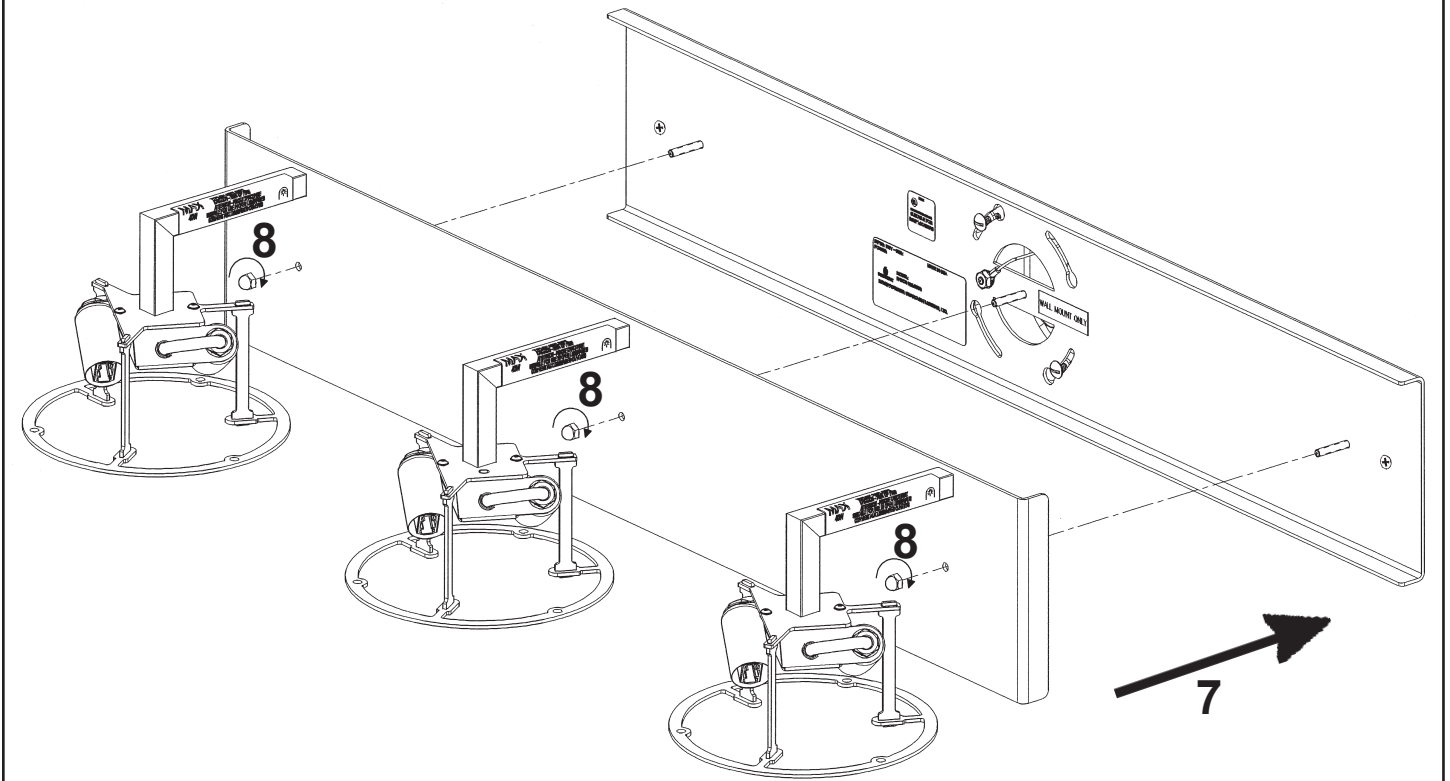
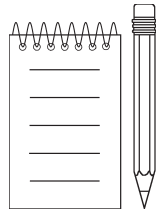

6 X  : JCD-G9-40 

