

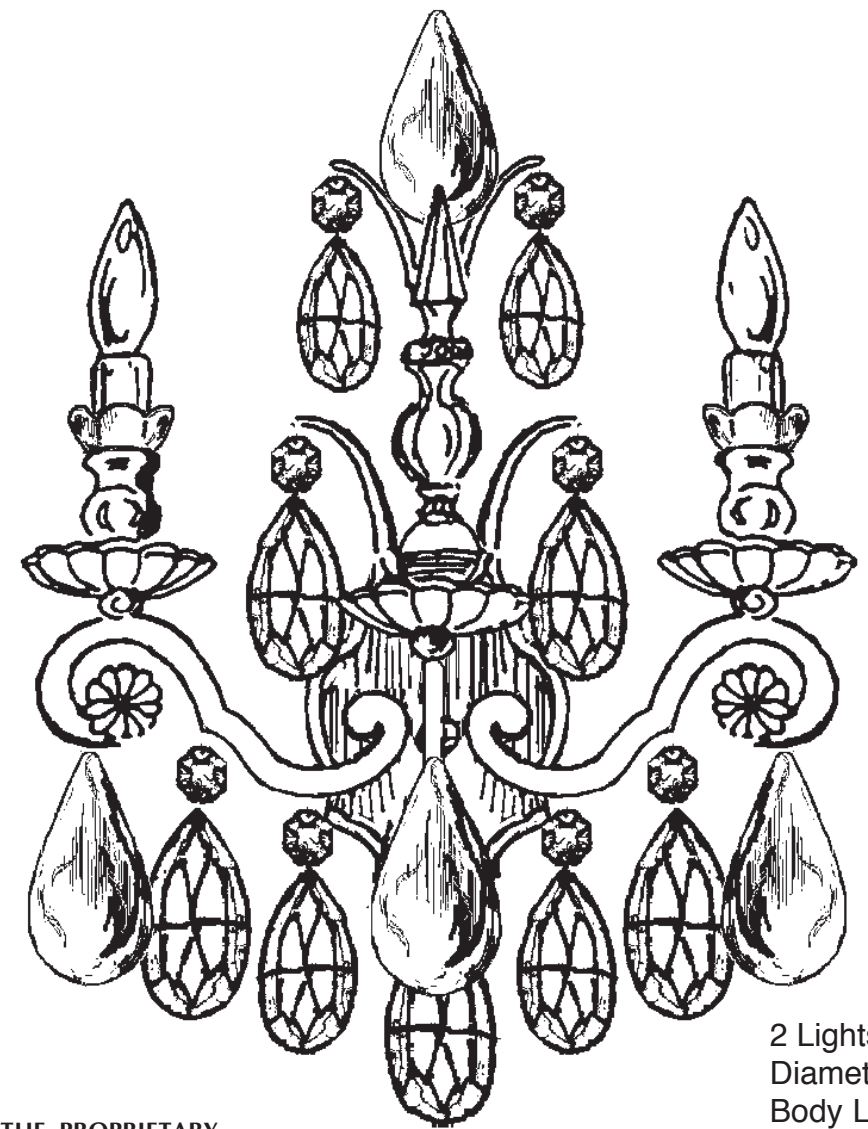

**SCHONBEK®**

**RENAISSANCE 3561- \_\_\_\_\_**



2 Lights  
Diameter: 15"  
Body Length: 22-1/2"  
Extension: 8"  
Hanging Weight: 8 lbs.

**T**HIS DESIGN IS THE PROPRIETARY  
TRADE DRESS/TRADEMARK OF  
SWAROVSKILIGHTING, LTD.



**SCHONBEK®**

MAX 60 W		110-120 V					

SCHONBEK® is a member of the Swarovski group.

All electrical components must be installed by a licensed electrician in accordance with the National Electric Code and the appropriate local electrical codes.

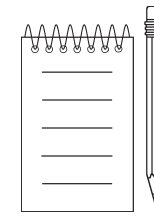
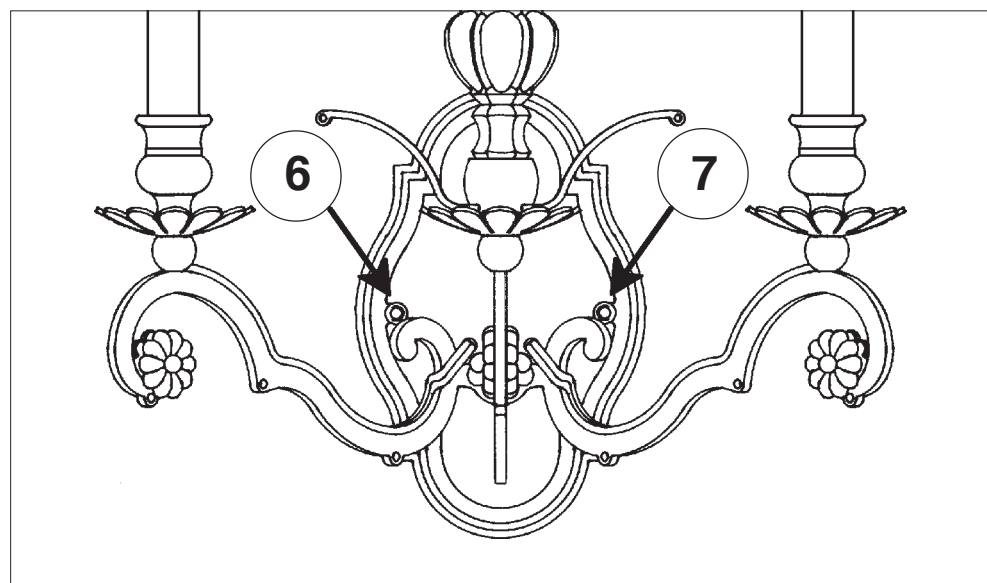
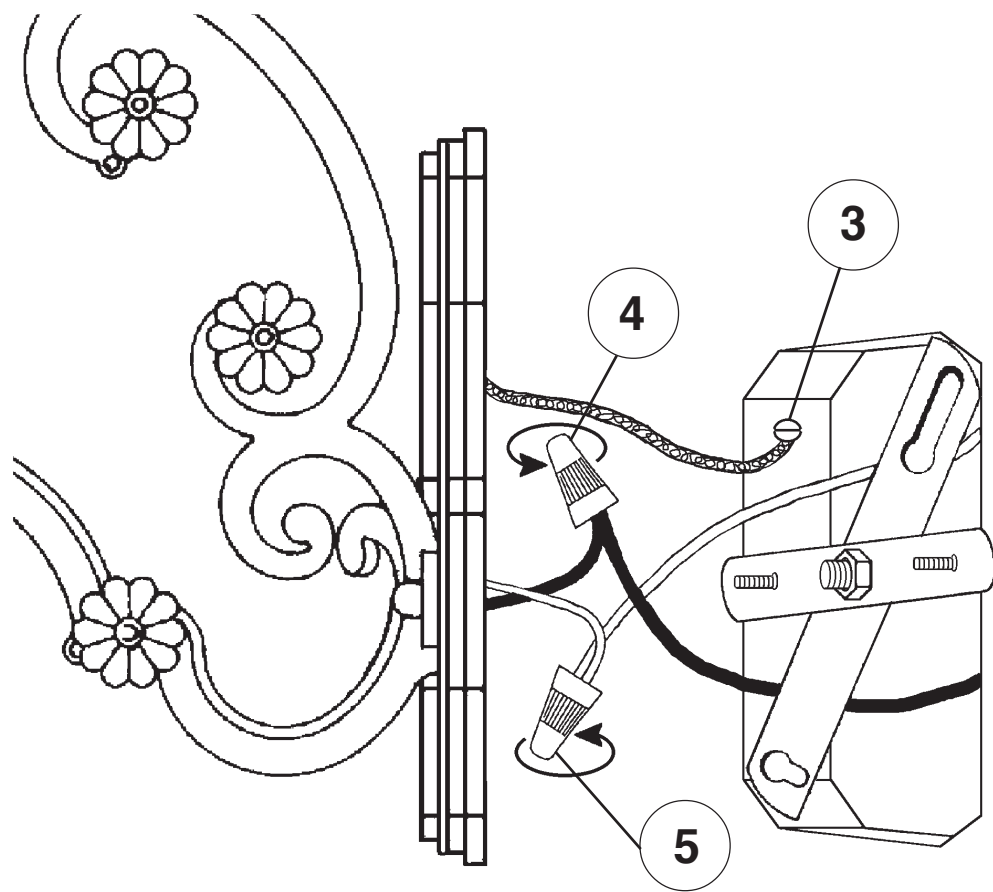
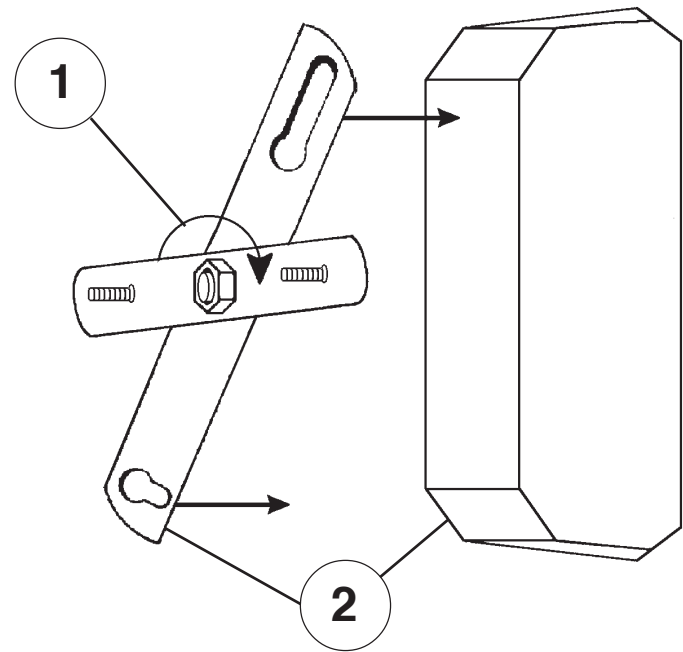

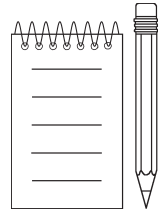

# SET #1



**A**  
(N1170)  
3"  
76mm

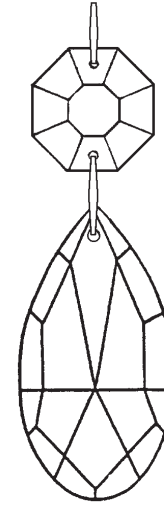

**B**  
(N10267-\*\*)   
2"  
50mm

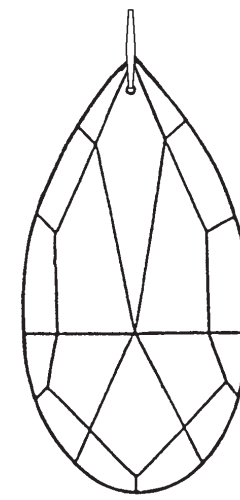

**C**  
(N8250)  
3"  
76mm

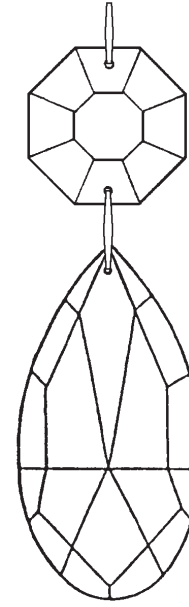

**D**  
(N10196-\*\*)   
2-1/2"  
63mm

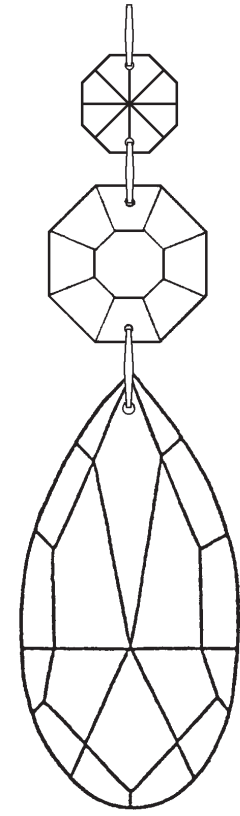

**E**  
(N10202-\*\*)   
2"  
50mm



**F**  
(N10193)  
3-1/2"  
89mm

# SET #2



**F**  
(N10193)  
3-1/2"  
89mm

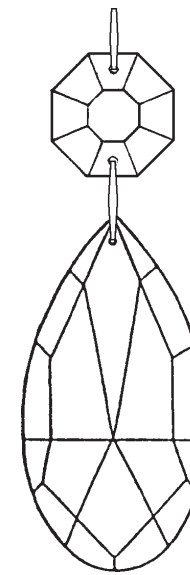

**G**  
(N10223)  
2-1/2"  
63mm

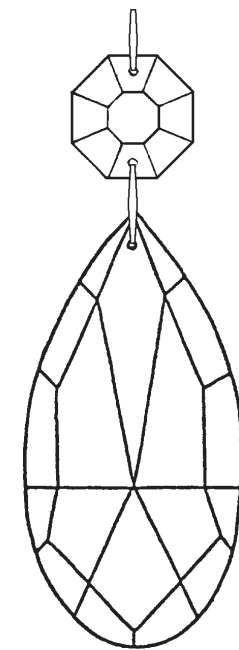

**H**  
(N10273-\*\*)   
3"  
76mm

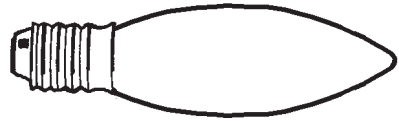

**9** 2 - B10  
60 Watts Max  
25 Watts Recommend

**Crystal Set #1 in Black**

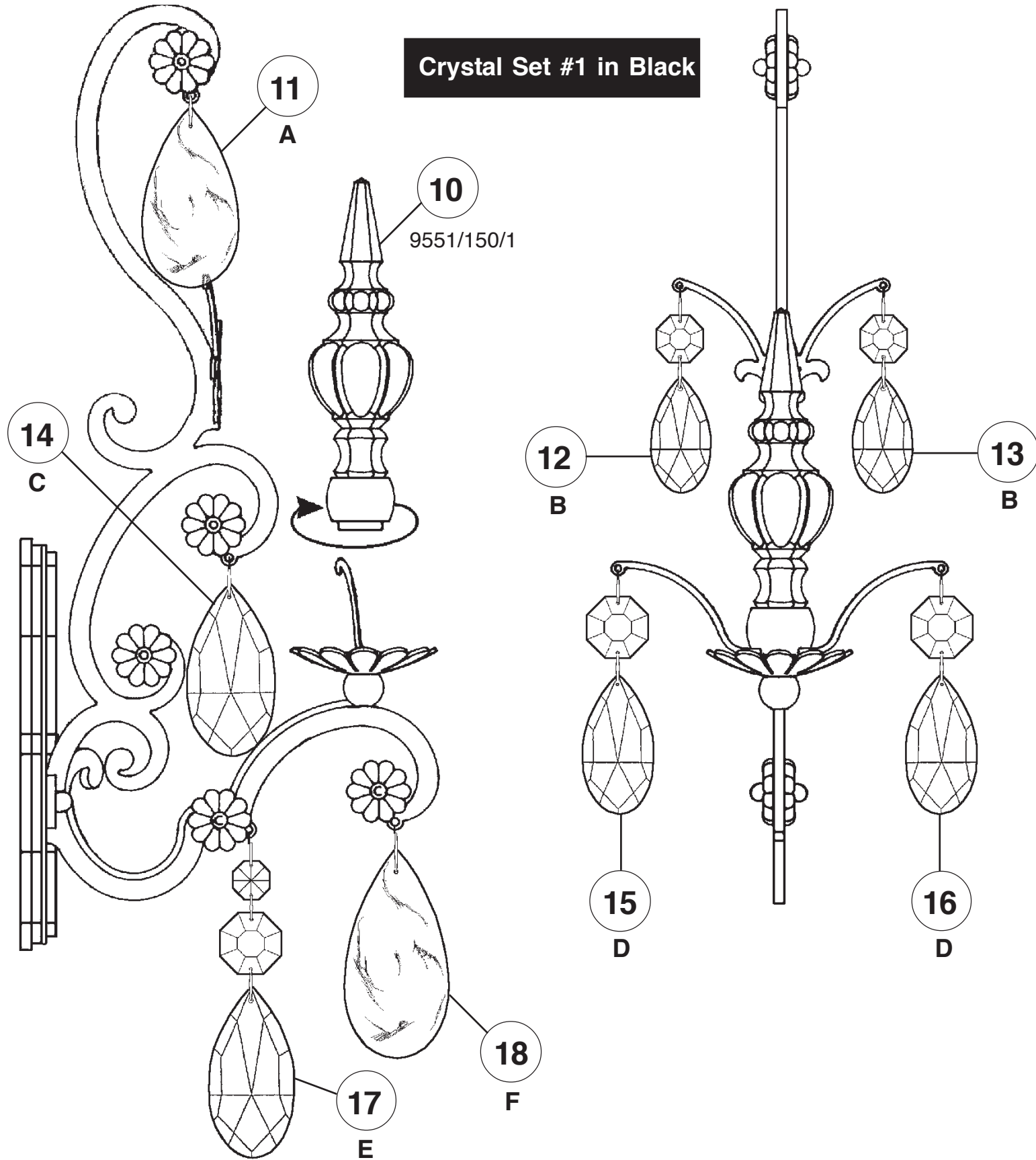

**Crystal Set #2 in Black**

