

# SCHONBEK®

## CHANDELIER 2473- \_\_\_\_ TRIM DIAGRAM

(Finish Option)

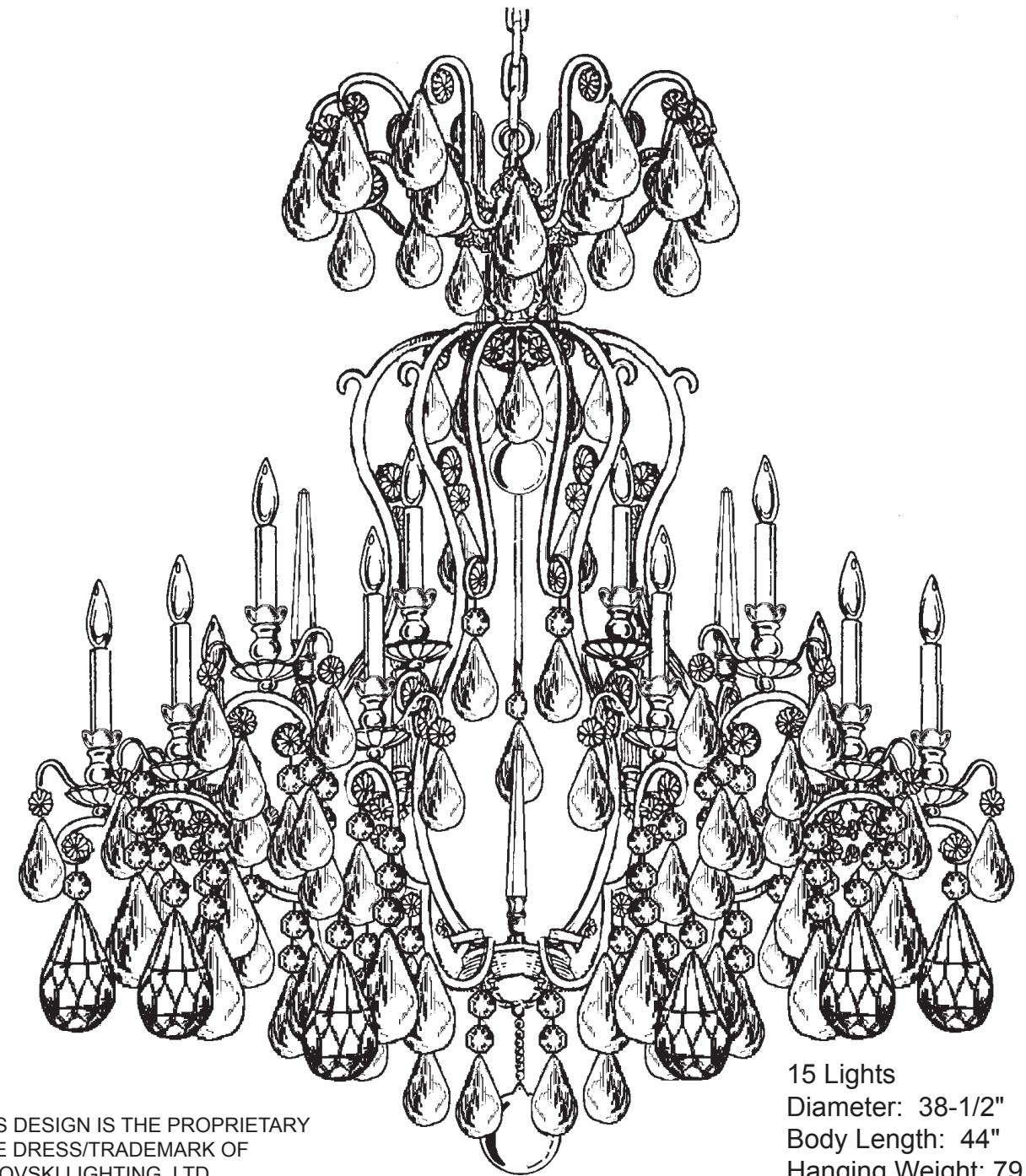

**T**HIS DESIGN IS THE PROPRIETARY  
TRADE DRESS/TRADEMARK OF  
SWAROVSKI LIGHTING, LTD.

15 Lights  
Diameter: 38-1/2"  
Body Length: 44"  
Hanging Weight: 79 lbs.

# SCHONBEK®

**Follow steps in exact order  
Save this trim diagram for future reference**

**1**

### IMPORTANT

*Person who opens carton should record the following information for future service.*

CODE # \_\_\_\_\_ Four-digit number on outside of carton.  
PACKER # \_\_\_\_\_ See crystal package label.  
ORDER # \_\_\_\_\_ See crystal package label.

# Instructions for electrician STEPS 2 - 21

**WARNING:**

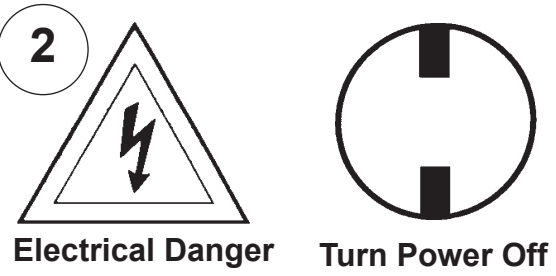

All electrical components must be installed by a licensed electrician in accordance with the National Electric Code and the appropriate local electrical codes.

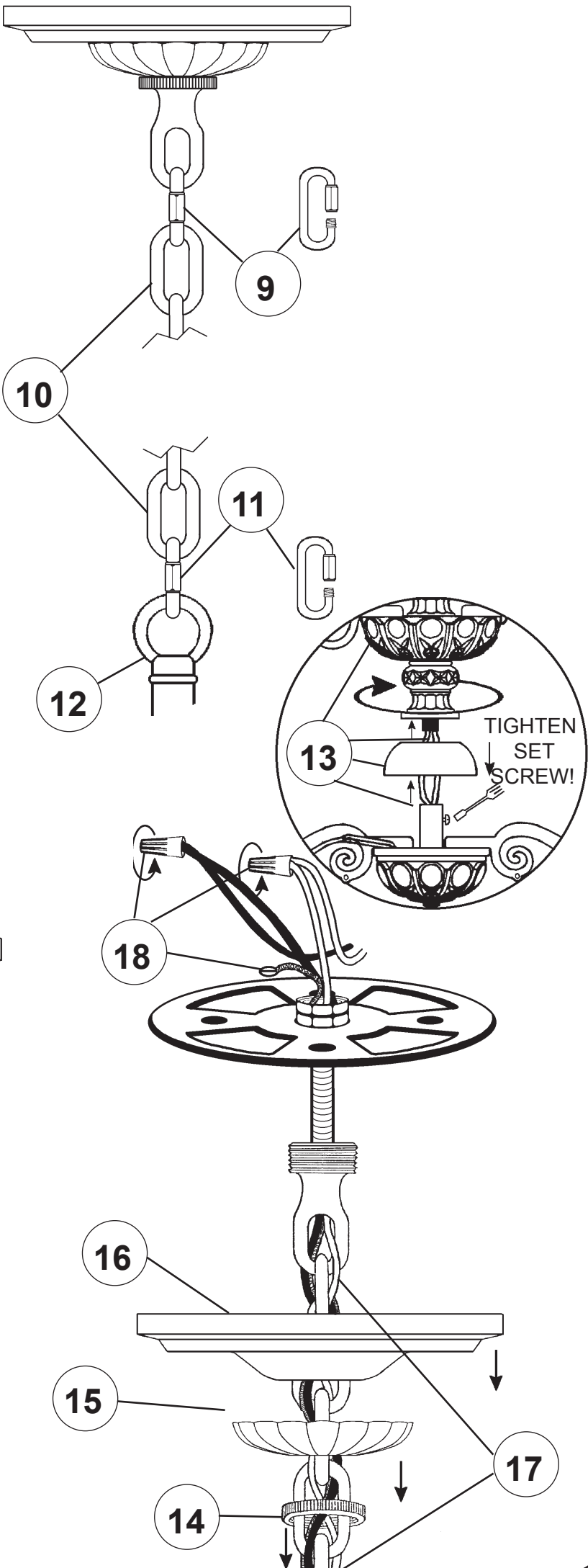
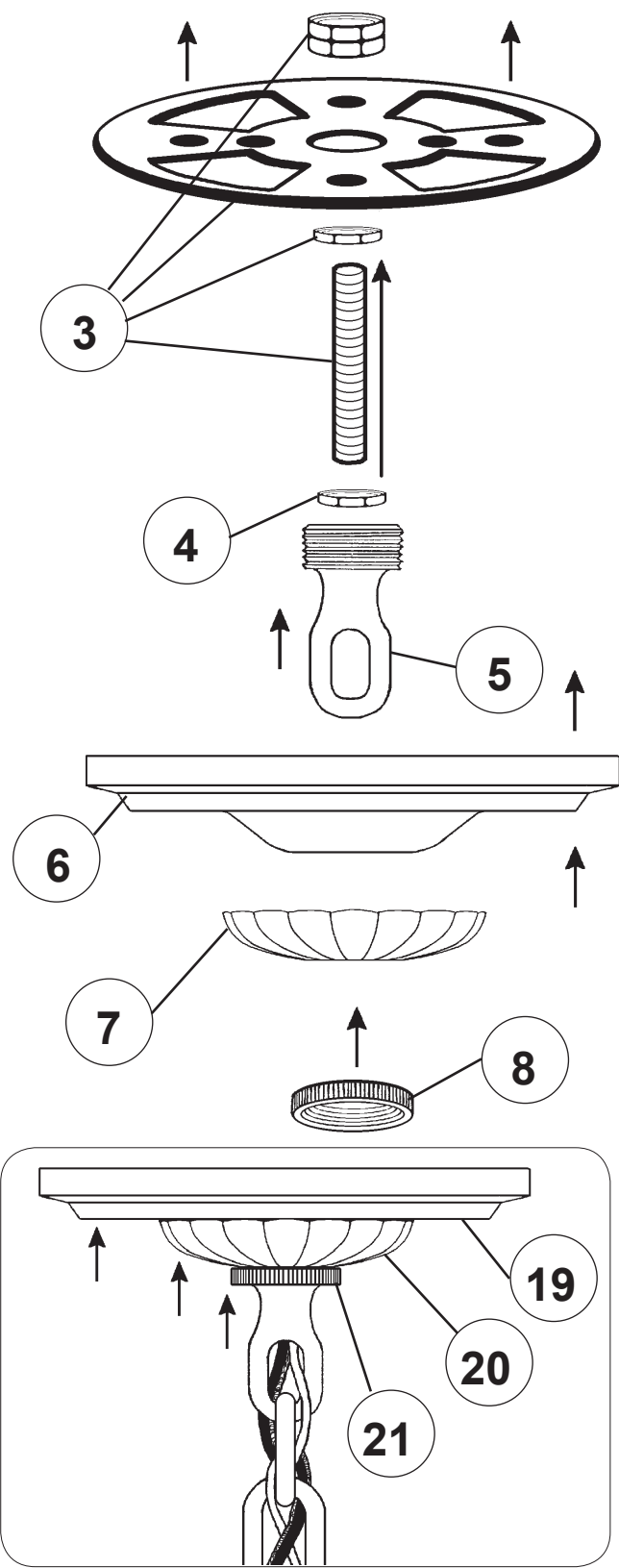

# CRYSTAL ID SHEET

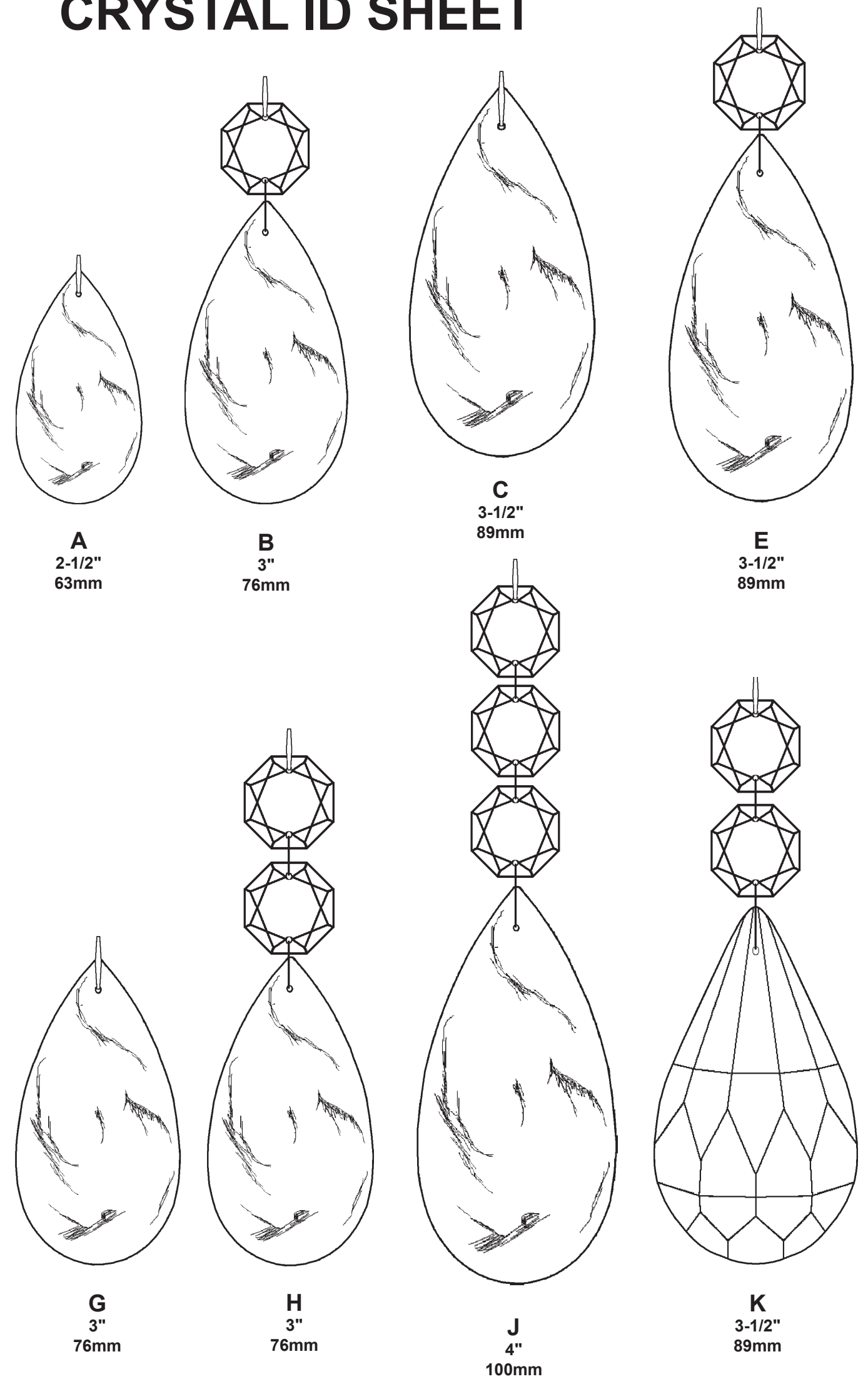

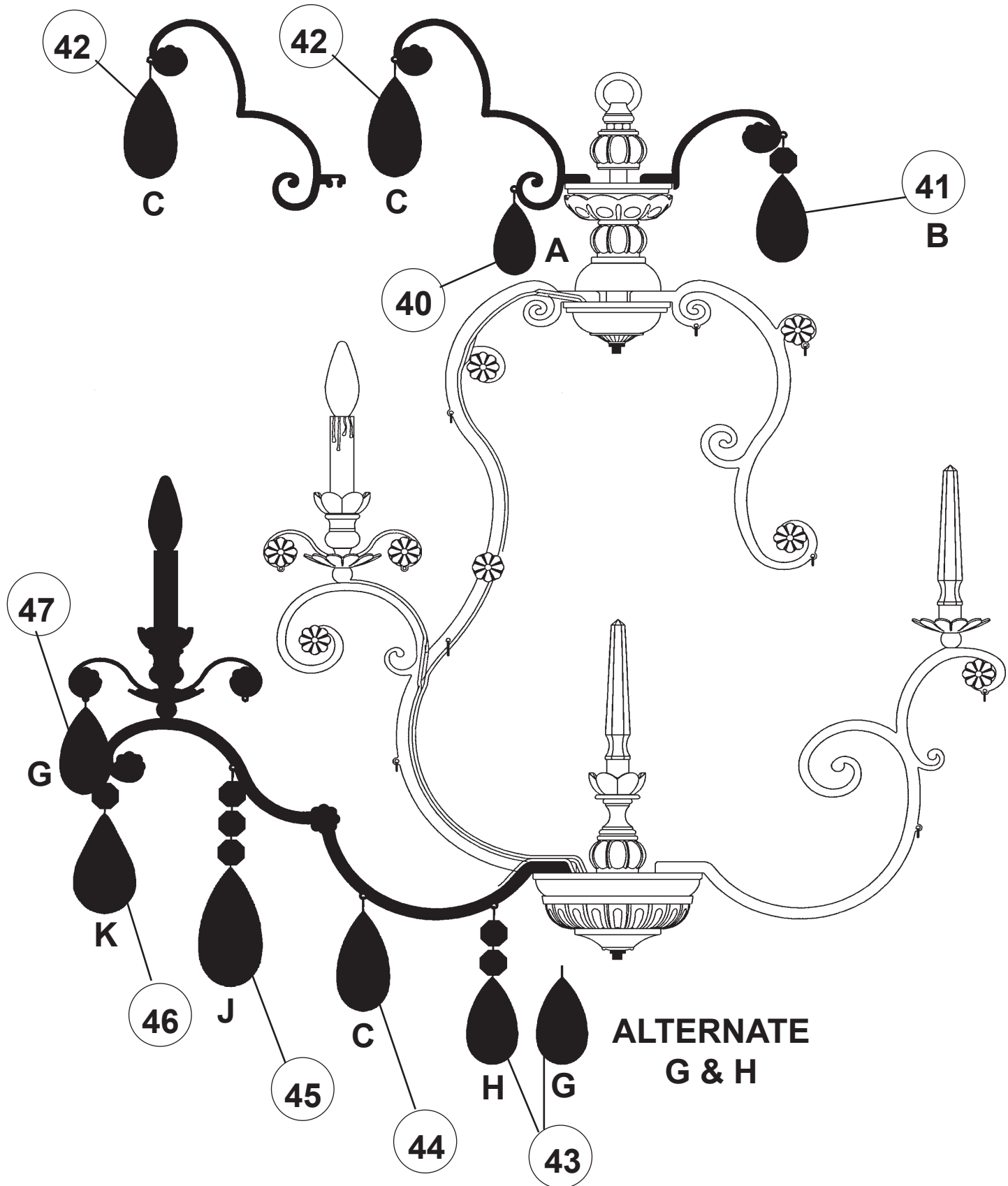

For easy removal of crystal from bubble pack, please cut along pouches on the inside of the seam. Gently remove crystal from the side of the pouch.

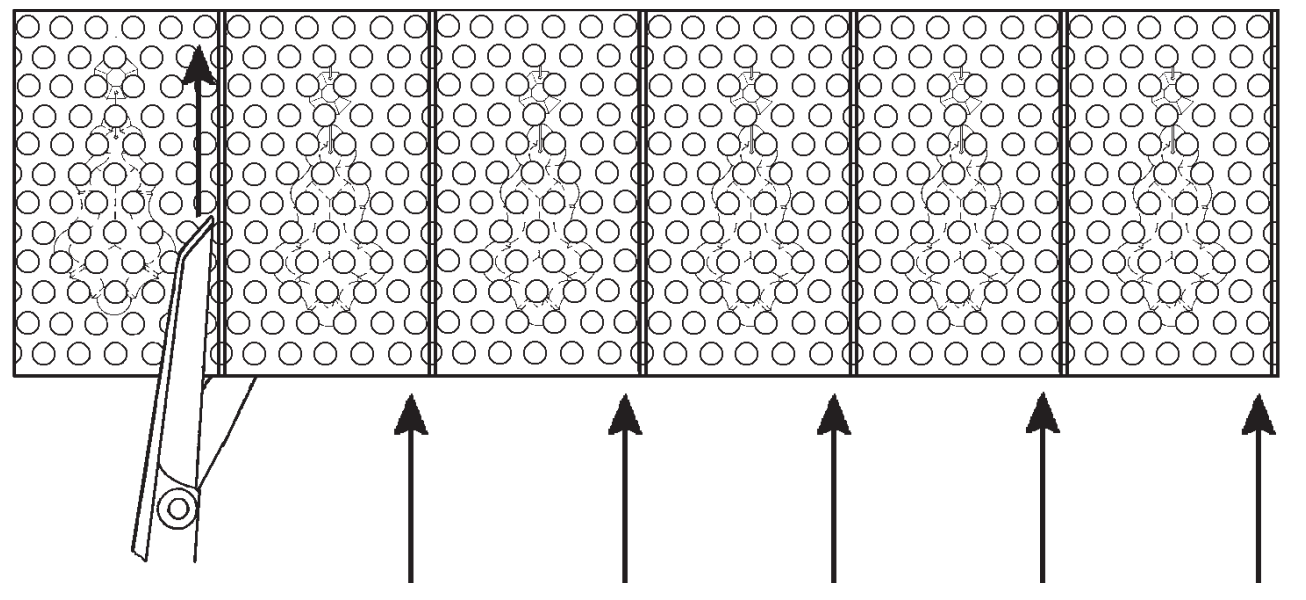

**NOTE:** Work on one crystal set at a time. Follow the black line from top to bottom according to the numbered steps on the trim diagram.

**Instructions for crystal trimming**  
**STEPS 22 - 47**

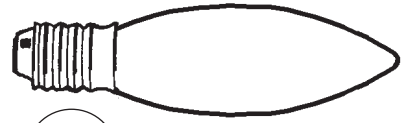

**22**

You will need 15 - B10  
 25 Watts Recommended  
 60 Watts Max

**27**

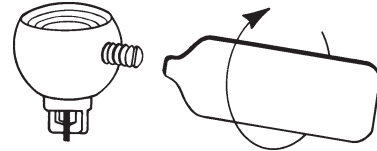

**Tighten With  
 Tool Provided.**

**25**

90072/7/1

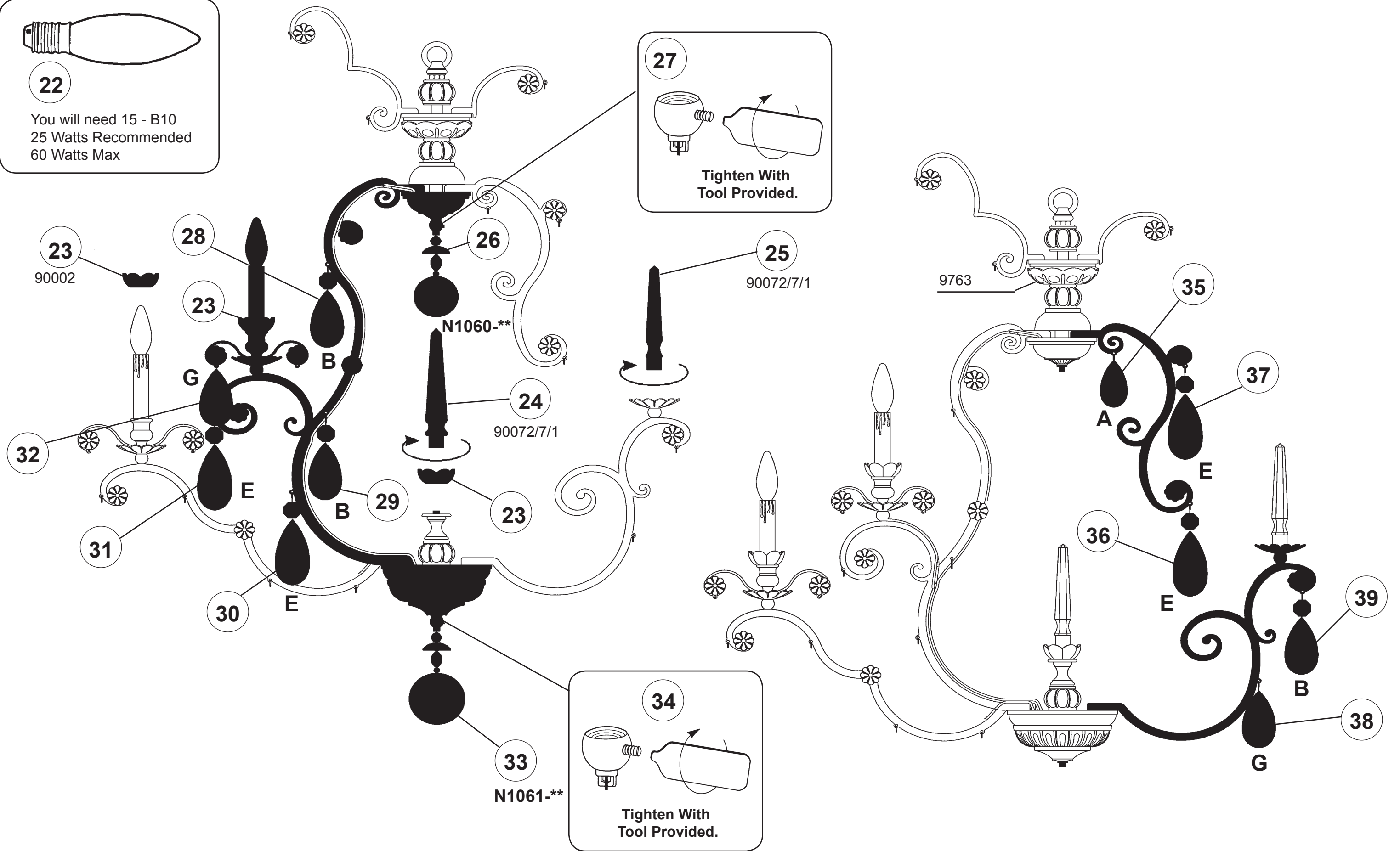

**34**

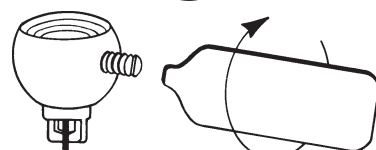

**Tighten With  
 Tool Provided.**

**33**

N1061-\*\*



**SPARE PARTS KIT  
 PROVIDED.**