

SCHONBEK®

CHANDELIER 2470- ____ TRIM DIAGRAM

(Finish Option)



THIS DESIGN IS THE PROPRIETARY TRADE DRESS/TRADEMARK OF SWAROVSKI LIGHTING, LTD.

6 Lights
Diameter: 22"
Body Length: 27"
Hanging Weight: 24 lbs.

SCHONBEK®

**Follow steps in exact order
Save this trim diagram for future reference**

1

IMPORTANT

Person who opens carton should record the following information for future service.

CODE # _____ Four-digit number on outside of carton.
PACKER # _____ See crystal package label.
ORDER # _____ See crystal package label.

Instructions for electrician
STEPS 2 - 21

WARNING:

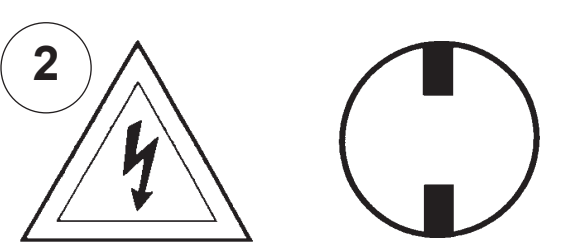

2 **Electrical Danger** **Turn Power Off**

All electrical components must be installed by a licensed electrician in accordance with the National Electric Code and the appropriate local electrical codes.

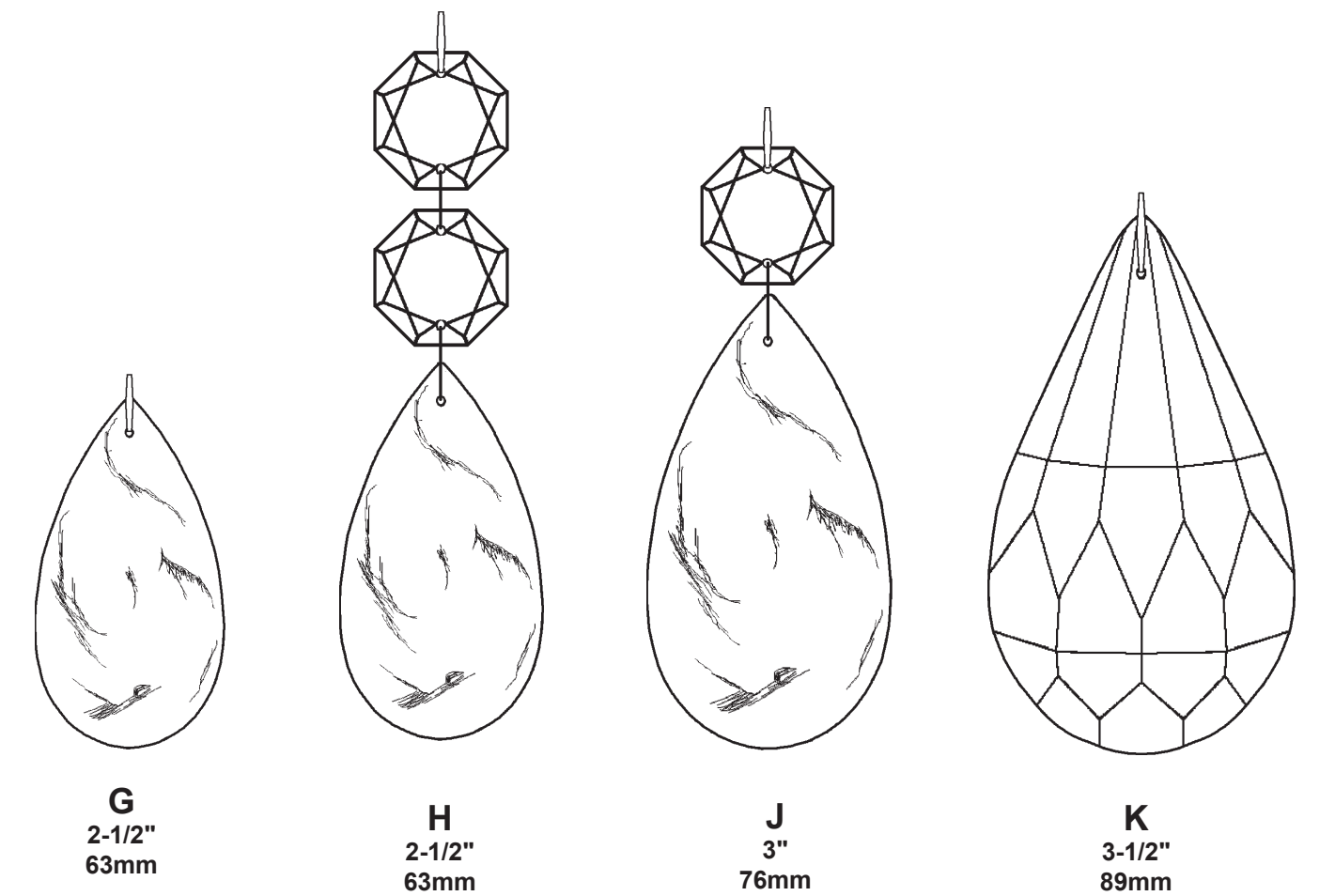
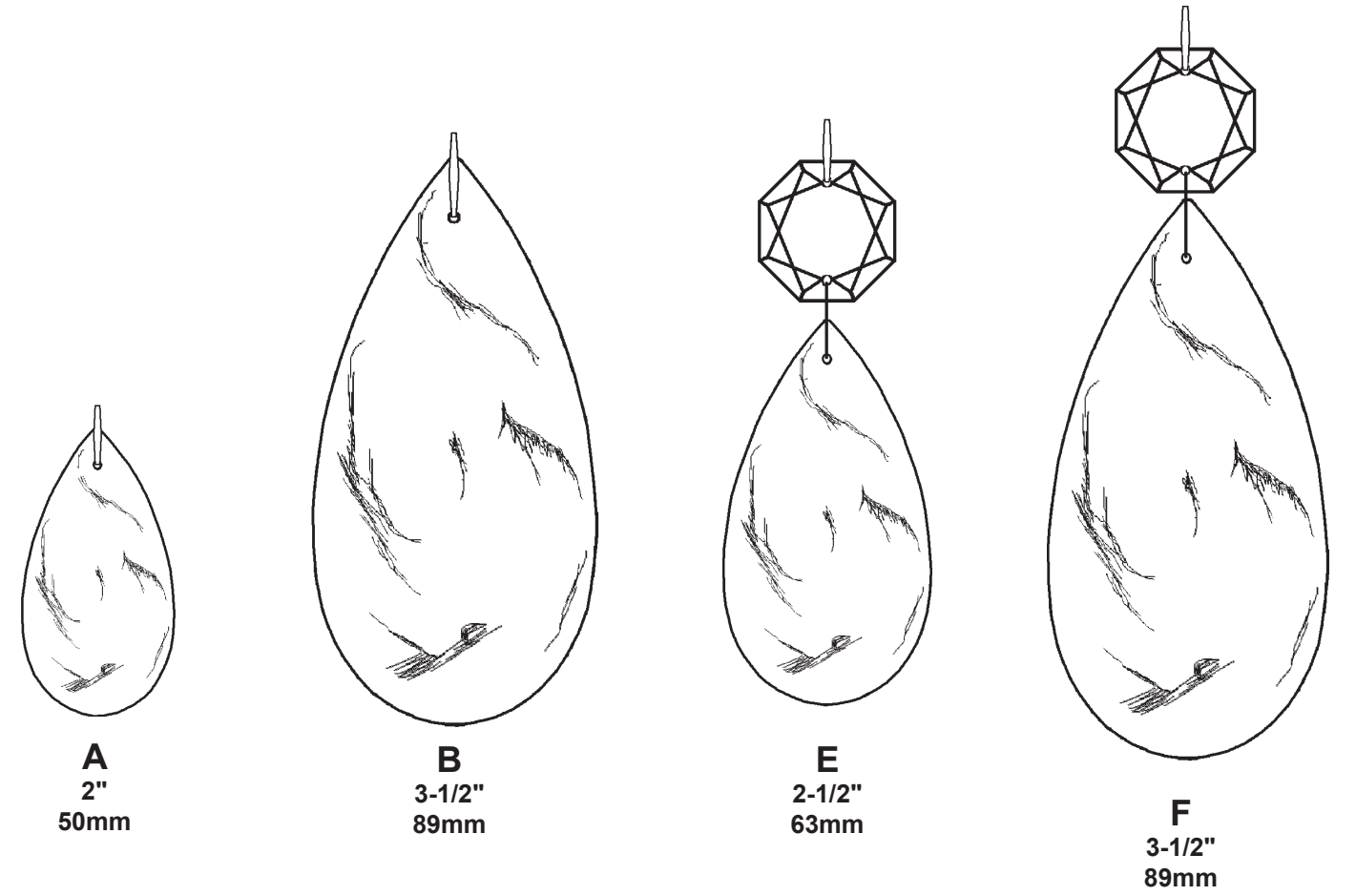
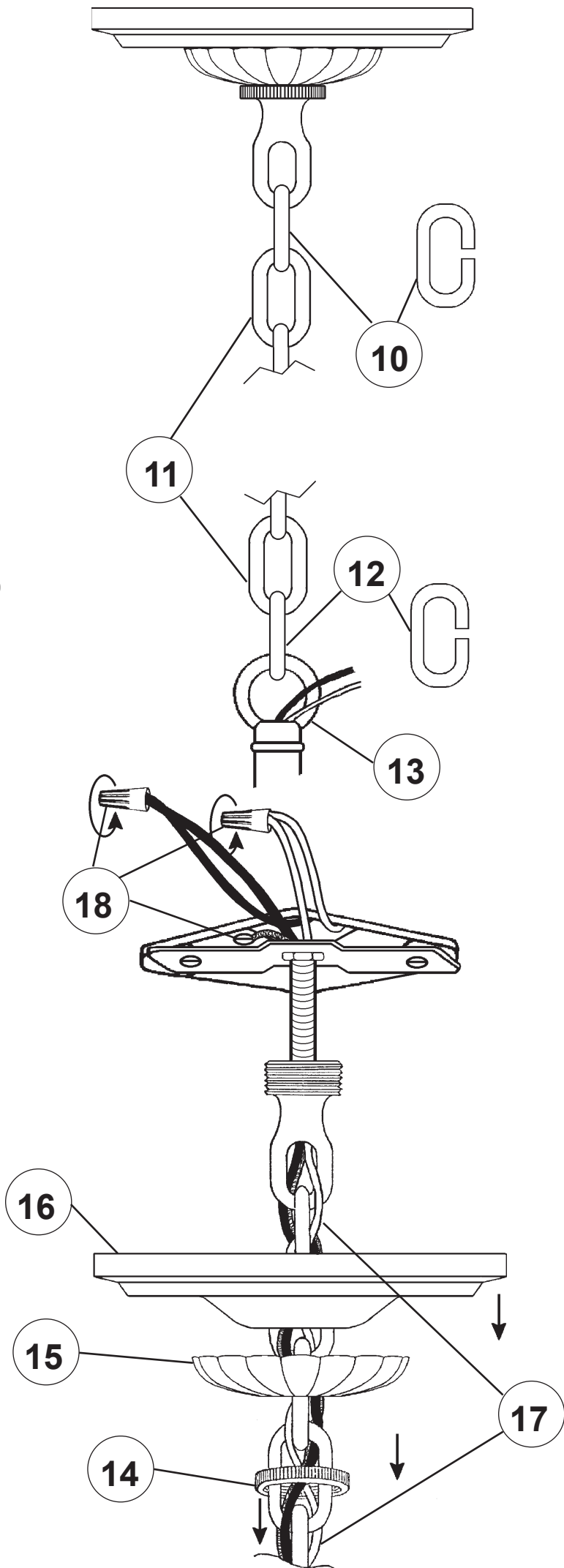
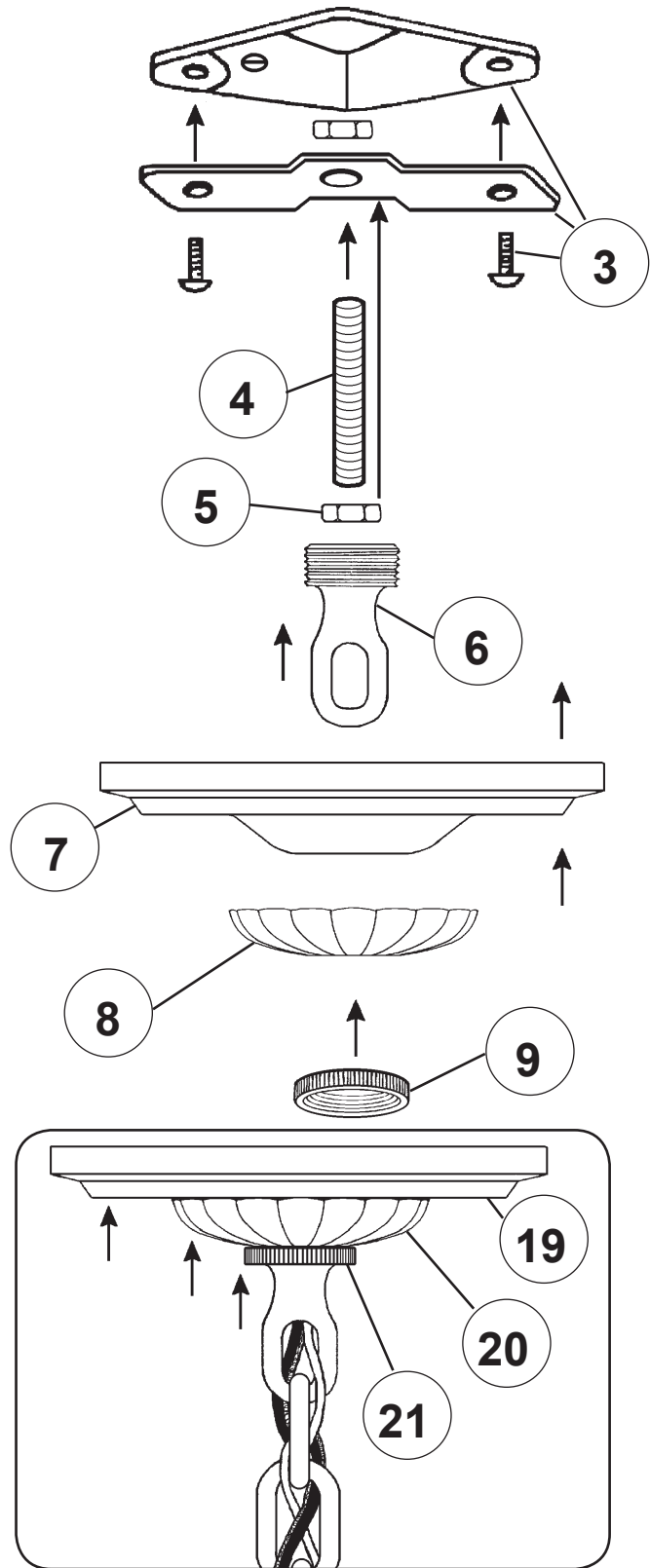

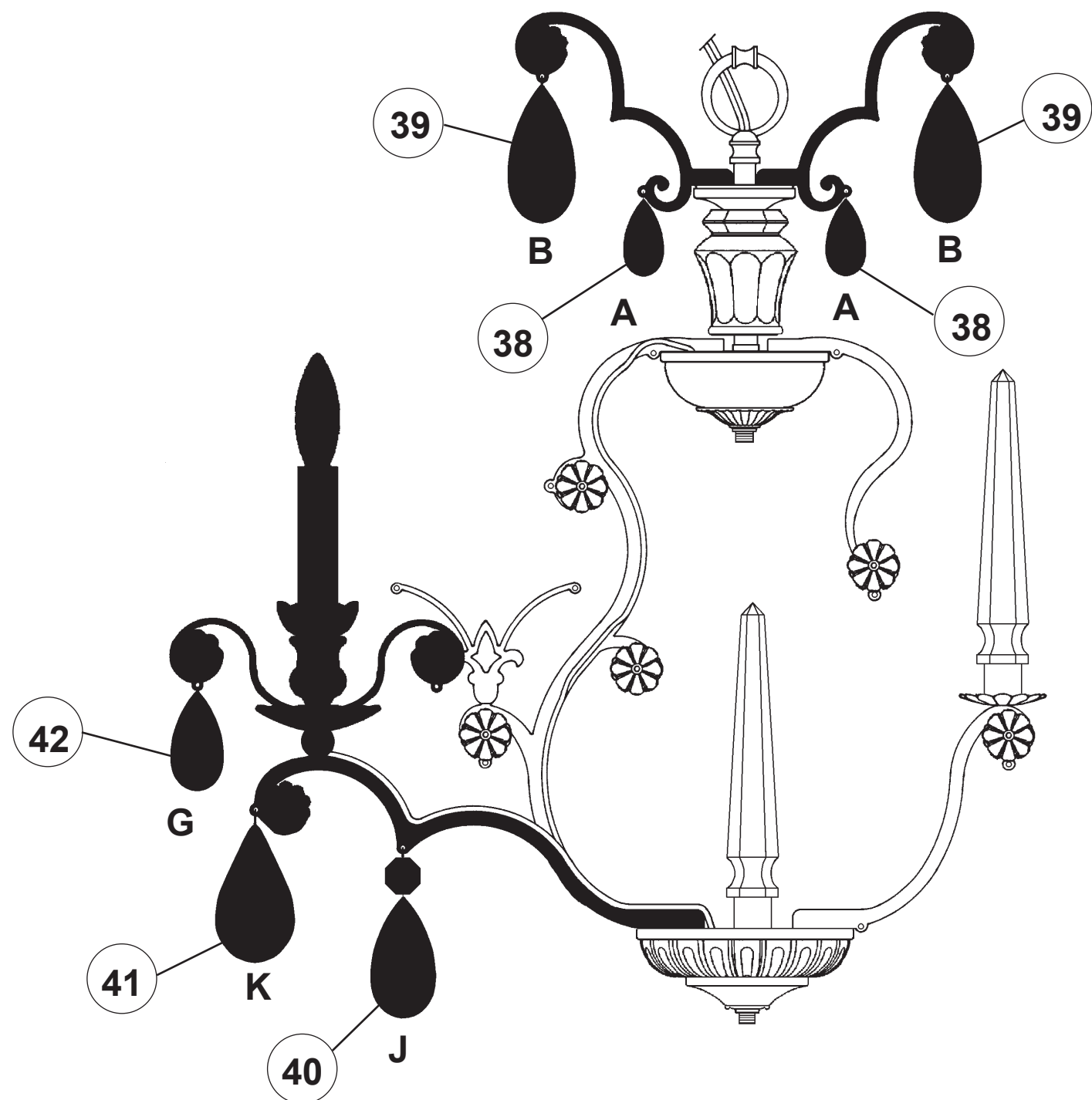

For easy removal of crystal from bubble pack, please cut along pouches on the inside of the seam. Gently remove crystal from the side of the pouch.

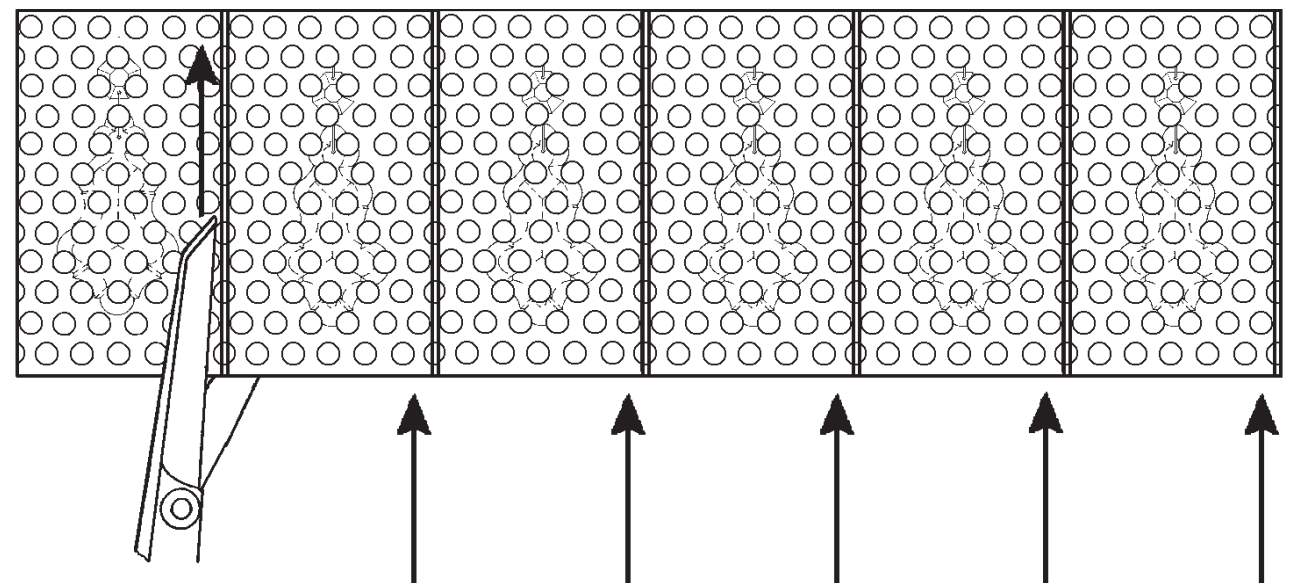

NOTE: Work on one crystal set at a time. Follow the black line from top to bottom according to the numbered steps on the trim diagram.

Instructions for crystal trimming
STEPS 22 - 42

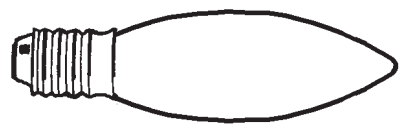

23
 You will need 6 - B10
 25 Watts Recommended
 60 Watts Max

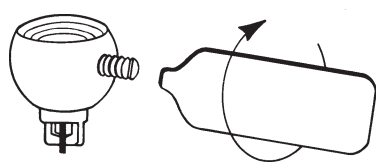

27
 Tighten With
 Tool Provided.

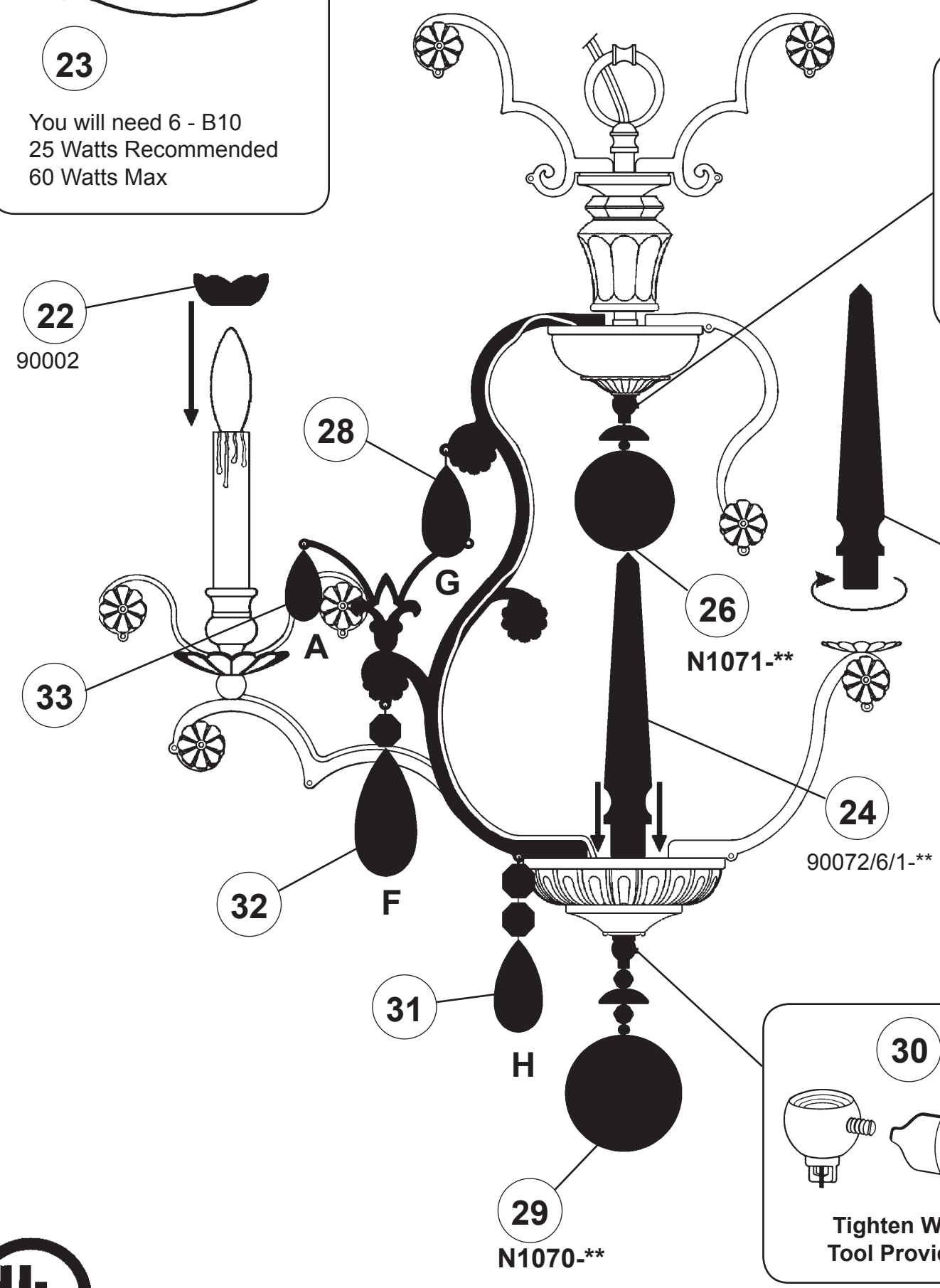
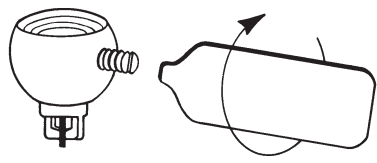
30
 Tighten With
 Tool Provided.

