

# TECHNICAL INFORMATION

# SIMPLEX AND DUPLEX LIFT STATIONS

# Sanicubic®

	SANICUBIC 1	SANICUBIC 2	SANICUBIC 1 VX	SANICUBIC 2 VX
Pump Type	Grinder	Grinder	Vortex	Vortex
Electrical	120V 60 Hz / 240V 60 Hz	240V 60 Hz	240V 60 Hz	240V 60 Hz
Amps	10A / 6A (240V)	13A	12A	2 x 12A
Motor	1 HP induction motor (no brushes or gears), oil-filled, thermally protected	2 x 1 HP induction motor (no brushes or gears), oil-filled, thermally protected	1.5 HP induction motor (no brushes or gears), oil-filled, thermally protected	2 x 1.5 HP induction motor (no brushes or gears), oil-filled, thermally protected
Capacitor Rating	60 uf	2 x 30 uf	30 uf	2 x 30 uf
Operating Temperature	158 F Max	158 F Max	158 F Max	158 F Max
Power cord length	80"	72"	98"	98"
Noise Level	<68 dBA	<68 dBA	<70 dBA	<70 dBA
Discharge Pipe Diameter	1-1/2"	1-1/2"	2" or 4"	2" or 4"
Max Discharge height (1.5")	36 Ft	36 Ft	n/a	n/a
Max Discharge height (2")	n/a	n/a	36 Ft	36 Ft
Max Discharge height (4")	n/a	n/a	20 Ft	20 Ft
Max Discharge across (1.5")	328 Ft	328 Ft	n/a	n/a
Max Discharge across (2")	n/a	n/a	328 Ft	328 Ft
Max Discharge across (4")	n/a	n/a	1640 ft	1640 ft
Discharge Rate at 36 Ft (1.5")	26 GPM	26 GPM	n/a	n/a
Discharge Rate at 36 Ft (2")	n/a	n/a	26 GPM	26 GPM
Discharge Rate at 20 Ft(4")	n/a	n/a	90 GPM	90 GPM
Discharge Rate at 36 Ft (1.5") both motors	n/a	38 GPM	n/a	n/a
Discharge Rate at 36 Ft (2") both motors	n/a	n/a	n/a	40 GPM
Discharge Rate at 20 Ft (4") both motors	n/a	n/a	n/a	110 GPM
Discharge Rate at 3 Ft (1.5")	50 GPM	50 GPM	n/a	n/a
Discharge Rate at 3 Ft (2")	n/a	n/a	125 GPM	125 GPM
Discharge Rate at 3 Ft (4")	n/a	n/a	137 GPM	137 GPM
Discharge Rate at 3 Ft (1.5") both motors	n/a	90 GPM	n/a	n/a
Discharge Rate at 3 Ft (2") both motors	n/a	n/a	n/a	145 GPM
Discharge Rate at 3 Ft (4") both motors	n/a	n/a	n/a	250 GPM
Shut-off head	45 Ft	45 Ft	43 Ft	43 Ft
Solids handling diameter	n/a	n/a	2"	2"
Capacity	8.5 gallons	12.4 gallons	15.9 gallons	31.7 gallons
Number of inlets	4	5	3	5
Inlets diameter sizes	1-1/2" or 4"	1-1/2" or 4"	1-1/2" or 4"	1-1/2" or 4"
Vent inlet size	1-1/2"	1-1/2"	2-1/2"	2-1/2"
Method of activation	Pressure switch, circuit board	Pressure switch, circuit board	Pressure switch, circuit board	Pressure switch, circuit board
Shower/bathtub base height	10"	10"	11"	12"
Weight	50 Lbs	77 Lbs	68 Lbs	223 Lbs
Certifying agencies	CSA (IPC, NSPC), IAPMO (UPC)	CSA (IPC, NSPC), IAPMO (UPC)	CSA (IPC, NSPC)	CSA (IPC, NSPC)



## IP68 RATED

- These systems are IP68 rated for possible submergence which eliminates any potential water damage to internal components.
- It comes equipped with an external control panel as well as a visual and audible alarm system with a 15 ft long cable.



## EASY ACCESSIBILITY

- New design allows easy access to major components without the need of disconnecting any pipes or removing the pump.
- Motor(s) and pressure switch compartment are easily removable from the top of the system for servicing and maintenance.



FOR RESIDENTIAL  
AND COMMERCIAL USE

Saniflo  SFA GROUP

Saniflo  SFA GROUP

[www.saniflo.com](http://www.saniflo.com)

800-571-8191

# Grinder Series

## GRINDER TECHNOLOGY

Constructed from hardened stainless steel, the grinder blade rotates against a stationary, perforated base plate, so that waste is quickly and easily dispersed through the base plate's holes before being pumped into the 1 1/2-inch discharge line.

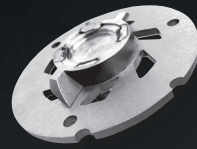

### Sanicubic 1

PART# 089 (120V)  
PART# 069 (240V)

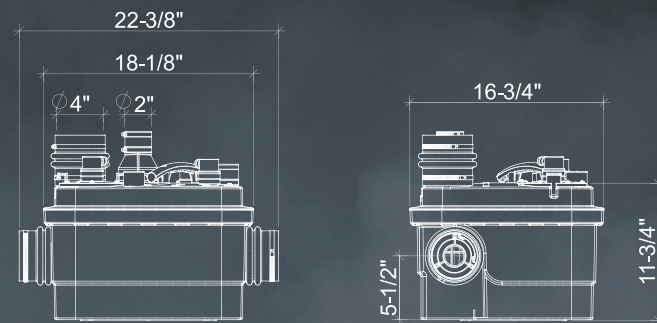

### Sanicubic 2

Part #029

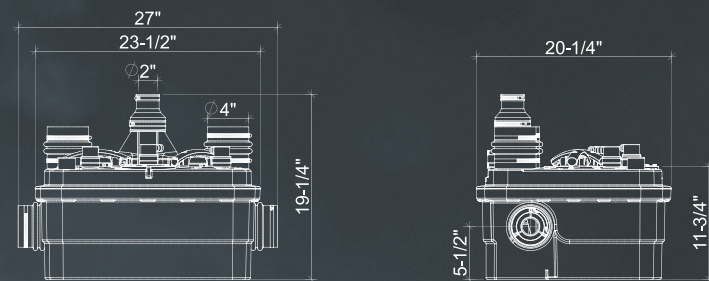

- Heavy duty simplex and duplex systems with 1 HP motors for residential and commercial applications.
- Incorporates a grinder system ideal for uncontrolled environments as it is designed to handle sanitary products.
- Capable of discharging through a 1 1/2-inch diameter pipe up to 36 feet vertical and/or 328 feet horizontal.
- Smart pump technology allows the discharge to increase up to 90 gallons per minute (with both motors in operation).
- For installations above and below ground as required in various applications.

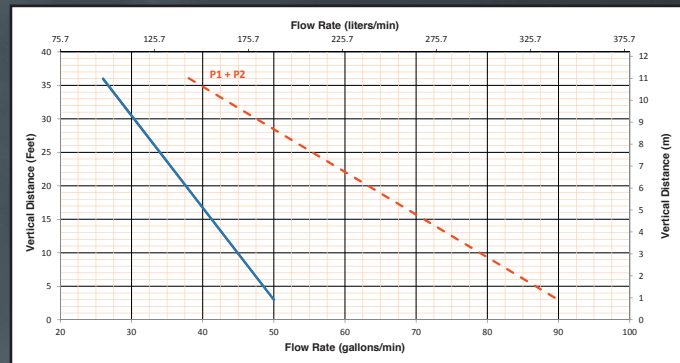

# Vortex Series

## VORTEX TECHNOLOGY

A specially designed pump impeller that creates a vortex action as the effluent enters the lift station enclosure. This technology keeps solids away from the impeller as it turns, pushing waste rapidly through the pump and to the discharge pipe. In doing so, the possibility of clogging is substantially reduced.

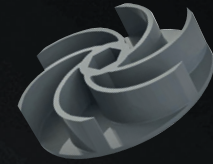

### Sanicubic 1VX

Part #049

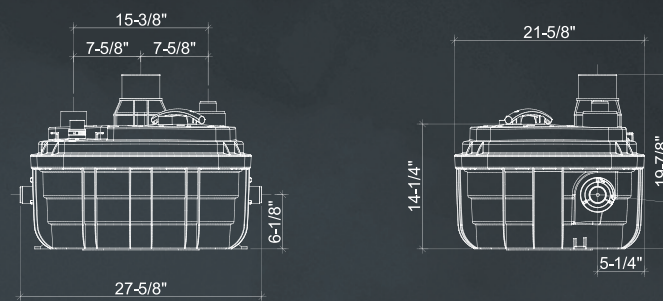

### Sanicubic 2VX

Part #099

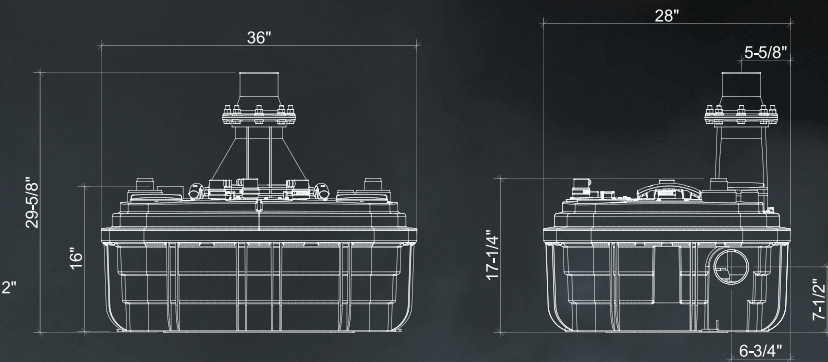

- Simplex and duplex systems with 1.5 HP motors for residential and commercial applications.
- Incorporates a vortex impeller capable of handling up to 2 inch solids
- Capable of discharging through a 2" or 4" diameter pipe up to 20 feet (4") or 36 feet (2").
- Smart pump technology allows the discharge to increase up to 250 gallons per minute (with both motors in operation with a 4" diameter pipe).
- For installations above and below ground as required in various applications.

