



FE710DRS

5.9 cu. ft. Freestanding Flex Dual Oven with Radiant Electric Range

Features

- Five Radiant Electric Cooktop Elements
 - One Triple Burner
 - One Dual Burner
 - Two Single Burners
 - Warming Center
- Dual Convection Oven Cook
 - Top: True Convection
 - Bottom: Fan Convection
- Large Oven Capacity – 5.9 cu. ft.
 - Top: 2.7 cu. ft.
 - Bottom: 3.0 cu. ft.
- SteamQuick™ – 20 min. Oven Cleaning
- Warming Drawer: High, Medium, Low
- Four Preset Menu Cook Options

Convenience

- Hot Surface Indicator Light
- Auto Oven Light (2)
- Proofing
- Sabbath Mode
- Kitchen Timer
- Delay Start
- Child Safety Lock
- Self-Clean (2 / 3 / 4 hrs.)
- 4 Easy Cook Pre-Sets
- Custom Cook
- Defrost
- 3 Chrome Oven Racks



Easy to use cook top and oven with a 1.4 cu. ft. Warming Drawer.



Controls at your fingertips with an easy to read LED display.



Generous 5.9 cu. ft cavity has more flexibility with a divider.

Signature Features

Available Colors

- Stainless Steel (shown)

Practical Warming Drawer

Perfect for keeping dishes warm while waiting the arrival of guests. The drawer also includes a hidden storage space for the oven divider, when maximum capacity is needed in the oven cavity.

Flex Oven allows More Flexibility

Unique construction allows multiple oven configurations: large single cavity or two smaller cavities – all with convection cooking. Provides the benefits of both a traditional single cavity range and a double oven in one. Unique smart divider allows two separate temperatures to be set at the same time— with no transfer of aroma.

Convection Cooking

Samsung's dual convection cooking system helps ensure all your baked goods come out of the oven cooked to perfection. Cook with true fan convection in the upper cavity and fan convection in the lower.



FE710DRS

5.9 cu. ft. Freestanding Flex Dual Oven with Radiant Electric Range

Installing your Range

* 30" minimum clearance between the top of the cooking surface and the bottom of an unprotected wood or metal cabinet; or 24" minimum when the bottom of the wood or metal cabinet is protected by not less than 1/4" flame retardant millboard covered with not less than no.28 MSG sheet steel, 0.015" stainless steel, 0.024" aluminum or 0.020" copper.

** 15" minimum between the countertop and the adjacent cabinet bottom.

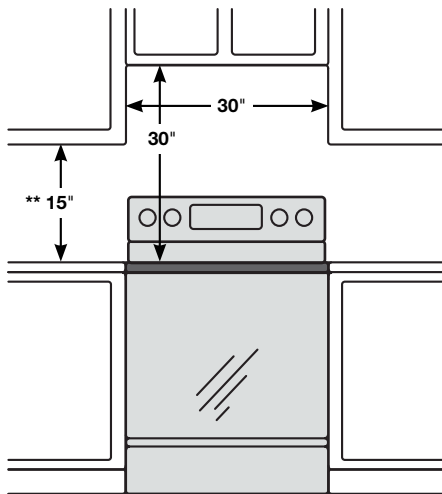

IMPORTANT: To eliminate the risk of burns or fire caused by reaching over heated surface units, cabinet storage space located above the surface units should be avoided. If cabinet storage is to be provided, the risk can be reduced by installing a range hood that projects horizontally a minimum of 5" beyond the bottom of the cabinets.

Dimensions

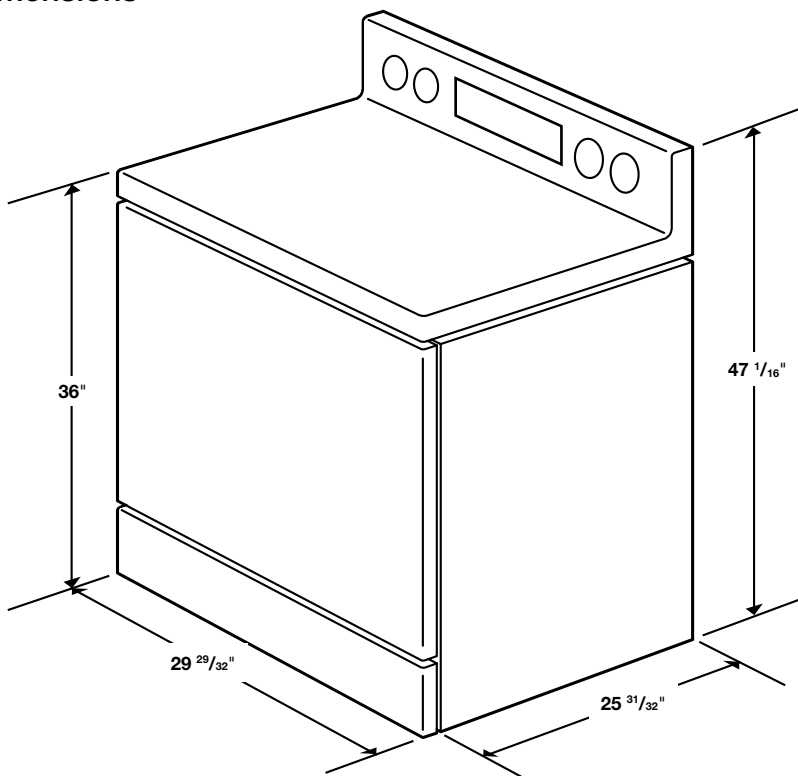

Power Consumption

13,750 W / 57.5 Amperes

Power Source

240 V / 60 Hz

Induction/Radiant Ceramic Cooktop

- Right Front: Radiant 6 / 9 / 12", 3.0 KW
- Left Front: Radiant 6 / 9", 3.0 KW – Fast Boil
- Right Rear: Radiant 6", 1.2 KW
- Left Rear: Radiant 6", 1.2 KW
- Center Rear: Warming Center, 100 W

Oven

- Hidden Bake Element: 3000 W (8 pass)
- Bake: 150°F - 550°F
- Convection Bake: 175°F - 550°F
- Broil Element: 3800 W (6 Pass)
- Convection Element/Heater: 1300 W
- Broil: Low / Hi (375°F / 450°F)
- Convection Roast: 175°F - 550°F
- Proofing
- Sabbath Mode

Warming Drawer

- Capacity – 1.4 cu. ft.
- Heating Performance: 600 W (4 pass)
- Temperature Settings: High, Medium, Low

Warranty

One (1) Year All Parts and Labor
Five (5) Years Electric Cooktop

Product Dimensions + Weight

Actual Oven Dimensions

(WxHxD) 25" x 20 25/32" x 18 15/16"

Outside Net Dimensions:

(WxHxD) 29 29/32" x 47 1/16" x 25 31/32"

Weight: 196 lbs / 89 kg

Shipping Dimensions + Weight

Dimensions: (WxHxD) 32 7/8" x 50 19/32" x 30 1/8"

Weight: 220 lbs / 100 kg

Color	Model #	UPC Code
Stainless Steel	FE710DRS	036725560475