

8536-1-HO-90

120V

Catalog #:		Type
Project:		Date
Prepared by:		

7" LED Slim Round High Output Disk

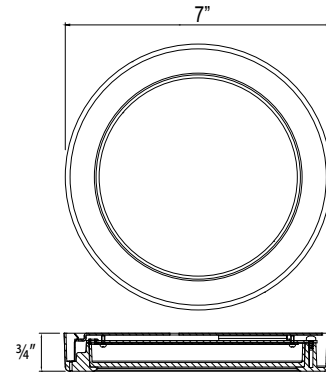

DESCRIPTION

A slim round LED Edge-lit Disk light that is an attractive and versatile solution for a slim-profile surface mount downlight. Suitable for use in wet locations, this is a great choice for most any residential or light commercial application. This disk has the benefits of higher lumen output and the higher 90 CRI.

DESIGN FEATURES

Construction

- Metal backplate and heat sink
- Frosted acrylic layered diffuser to reduce glare and provide even light distribution

Electrical

- 120V-60Hz
- Dimmable TRIAC or ELV, 10-100%
- 50,000 hour projected life
- 15.1W | 1267 lms (delivered)
- 90 CRI | 3000K or 5CCT Selectable: 27K, 3K, 35K, 4K, 5K

Installation

- Mounting bracket included for installation in 3" or 4" J-Box applications
- Retrofit option includes torsion springs and E26 base adapter for mounting in 5/6" housings

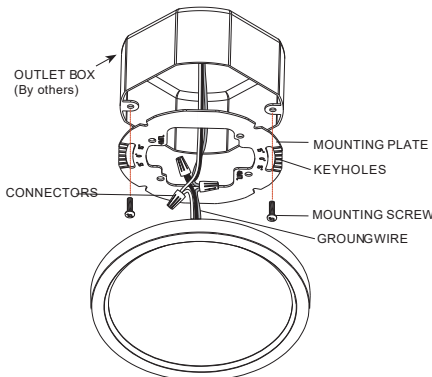

EM Battery Pack (sold separately)

- Empty Filler Housing also available
- See page 2 for further information

Certifications

- CEC JA8 Compliant (8536-1-HO-90-3K only)
- Energy Star Listed (8536-1-HO-90-3K only)
- 8536-1: cCSAus Listed for wet location
- LED Light Source: 5 Year Limited Warranty
- Non-Electrical: 1 Year Limited Warranty
- Suitable for use in closets when installed in accordance to NEC Section 410.16 (C)(1)

ORDERING GUIDE

Example: 8536-1WH-HO-90-3K-R

Model #	Finish	CRI	CCT	Retrofit
8536-1				
8536-1	BN : Brushed Nickel BK : Black WH : White	-HO-90	-3K :3000K -5CCT	(blank) No Retrofit -R : Retrofit

ORDERING GUIDE

Example: 4785WH-EM

Model #	Finish	Option
4785		
4785	BN : Brushed Nickel BK : Black WH : White	-EM : Battery Backup with Test Switch -F : Empty Filler Housing Only



LED Lamps
Other Components

TEL: 800.937.6925 | Fax: 800.207.9509 | www.rplighting.com

Specifications and dimensions subject to change without notice.

7/24/23 R2



RP LIGHTING · FANS

8536-1-HO - 7" Slim Round HO Disk

4785EM

120V-60Hz

Catalog #:		Type
Project:		Date
Prepared by:		

7" LED Flush Mount Emergency Battery Back-up

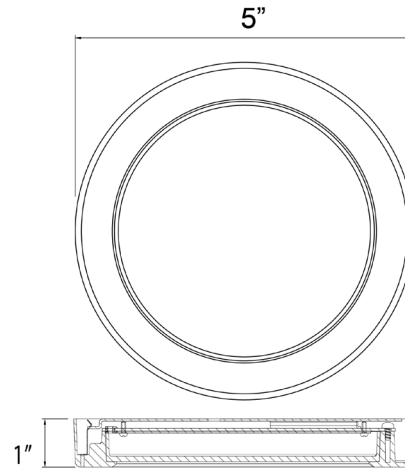

DESCRIPTION

For use with the RP Lighting's 8536-1 disk, this maintenance-free emergency battery back-up unit with rechargeable Ni-MH battery allows for emergency power down corridors or open applications. With the blank empty filler unit you can now have a similar appearance in the space when using the emergency unit.

DESIGN FEATURES

Construction

- Durable metal backplate and heat sink to facilitate heat dissipation

Electrical

- 120V - 60Hz
- Non-Switch Loads Only (Always On Applications)
- Battery - 11.1V / 2.6Ah Ni-MH Re-chargable; up to 24 hours charge time
- Emergency Output - 20% of nominal power
- Provides over 120 minutes when normal power fails
- LED Indications - Red - Charging; Green - Fully Charged; Yellow - Faulty
- Operating Temperature - 0°C (32°F) to +55°C (+131°F)
- Test Switch / Charging Indicator Light: 4W-ITS
- (4-wire illuminated test switch) included on 4785EM

Installation

- For use with 8536-1 disks from RP Lighting
- One-piece emergency battery back-up unit allowing for 3" or 4" J-Box installation

Certifications

- 4785-EM: cCSAus Listed to UL924 standards
- cCSAus listed for damp location
- 4785-EM: 1 Year Limited Warranty
- 4785-F: 1 Year Limited Warranty

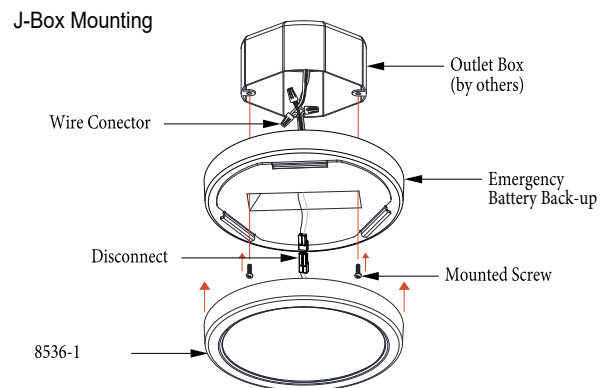

TEL: 800.937.6925 | Fax: 800.207.9509 | www.rplighting.com

Specifications and dimensions subject to change without notice.

7/24/23 R2