

# Polystyrene Folding Adirondack Chair

## ASSEMBLY INSTRUCTIONS

### **Before You Begin:**

Please identify all component parts and hardware pieces required before you begin. Carefully remove all of the components from the packaging and set aside for assembly. Assemble on a soft surface to prevent scratching during assembly.

### **Caution:**

Tighten all components securely before use. Failure to do so may result in personal injury. DO NOT use any sharp objects to open plastic wrapped components as damage to product or components may result.

### **Warning:**

**CHOKING HAZARD** - Small Parts. Adult Assembly Required.



### **DO NOT ALLOW CHILDREN TO CLIMB ON FURNITURE**

Serious or fatal injuries can occur from furniture tipping over. You must install Tipping Restraint Hardware (where included) to help prevent the unit from tipping and causing accidental injury, instability, death or damage. The tipping restraint is intended only as a safety measure, it is not a substitute for proper adult supervision.

To help prevent furniture from tipping over it must be permanently attached to the wall. Anti-Tip Safety Wall Straps suitable for the unit weight and wall materials (if not included) should be purchased and installed.

---

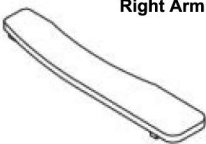
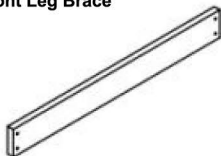
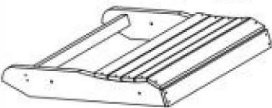
# PARTS

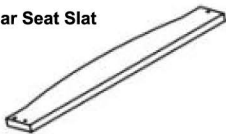
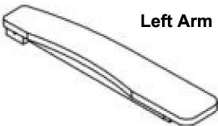
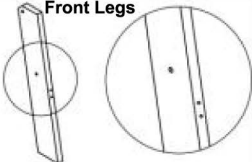



A	 Backrest	1PC	D	 Right Arm	1PC	G	 Front Leg Brace	1PC
B	 Seat	1PC	E	 Folding Connector	2PCS	H	 Rear Seat Slat	1PC
C	 Left Arm	1PC	F	 Front Legs	2PCS			

## TOOLS REQUIRED (not included)

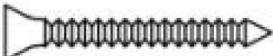

Phillips screwdriver

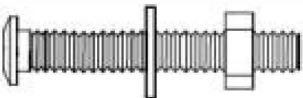
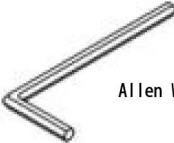
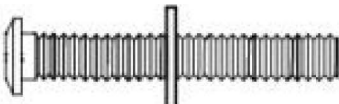
## Hardware Included

AA	 4*35 Screw	8PCS	DD	 M8*80 Bolt	2PCS
BB	 M8*50 Bolt	6PCS	EE	 Allen Wrench	1PC
CC	 M8*50 Bolt	2PCS	FF	 Open End Wrench	1PC

## STEP 1

Attach the Rear Seat Slat (Part H) to the Seat (Part B) using (4) 4\*35 Screws (Part AA) and a Phillips Screwdriver.

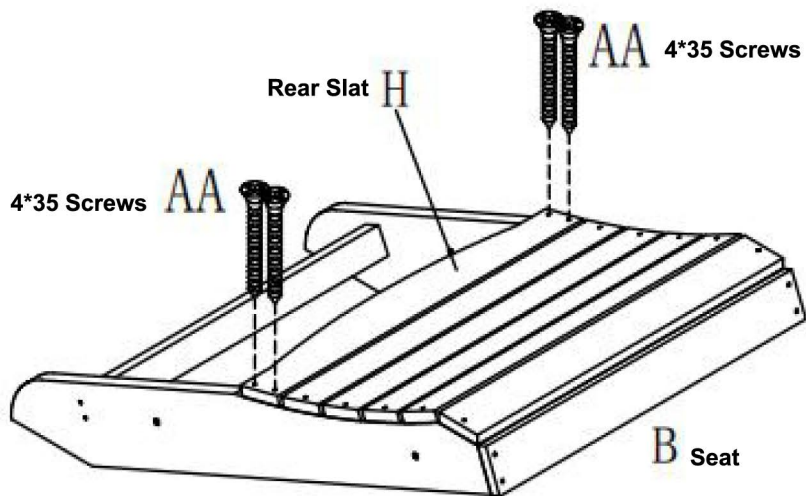

## STEP 2

Attach the Front Legs (Part F) to the Seat (Part B) using (2) M8\*50 bolt sets (Part BB). Tighten using the Allen Wrench (Part EE) and Open End Wrench (Part FF).

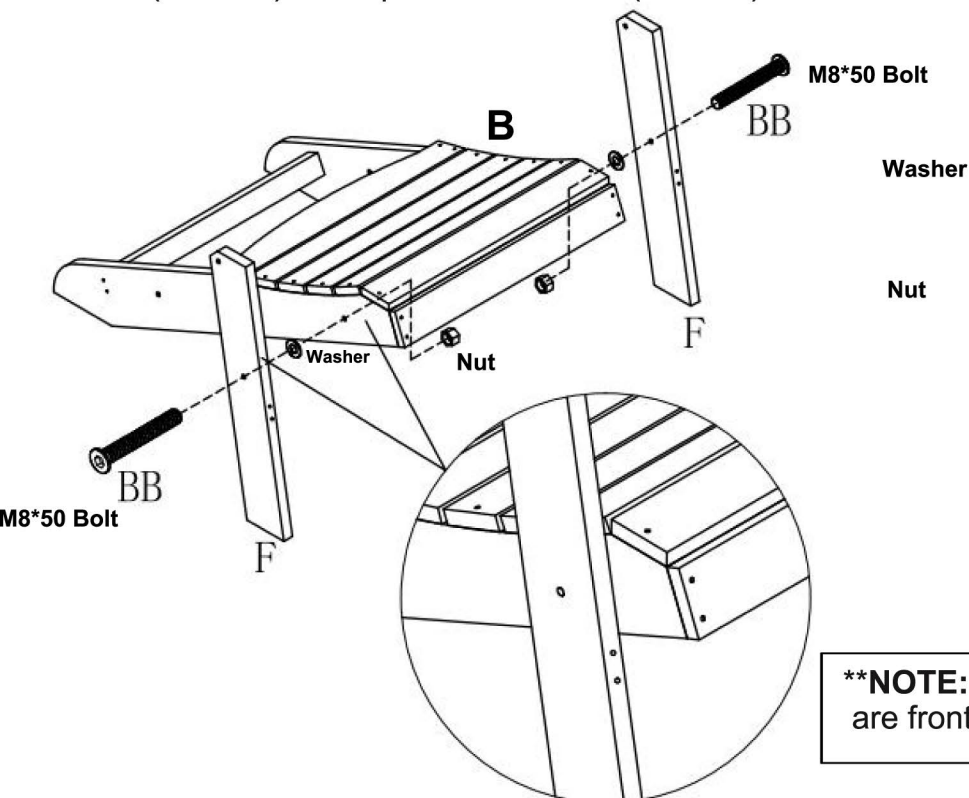

**\*\*NOTE:** Ensure pre-drilled hole on front legs are front facing

### STEP 3

Attach the Front Leg Brace (Part G) to the Legs (Part F) using (4) 4\*35 Screws (Part AA)

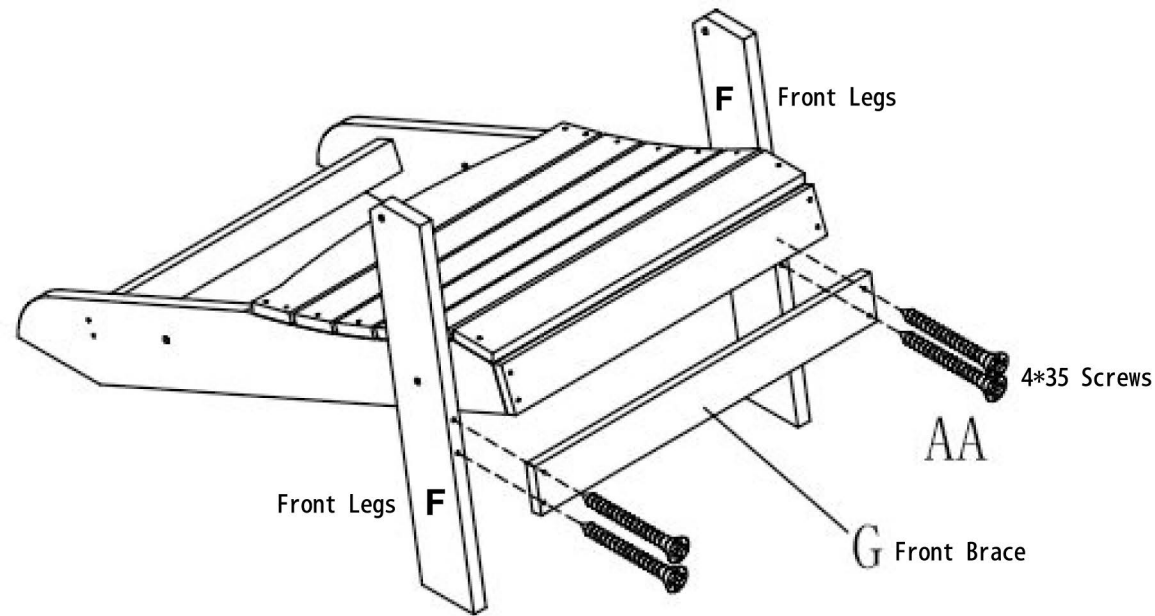

### STEP 4

Attach the Folding Connectors (Part E) to the Seat (Part B) using (2) M8\*50 bolt sets (Part BB). Tighten using the Allen Wrench (Part EE) and Open End Wrench (Part FF).

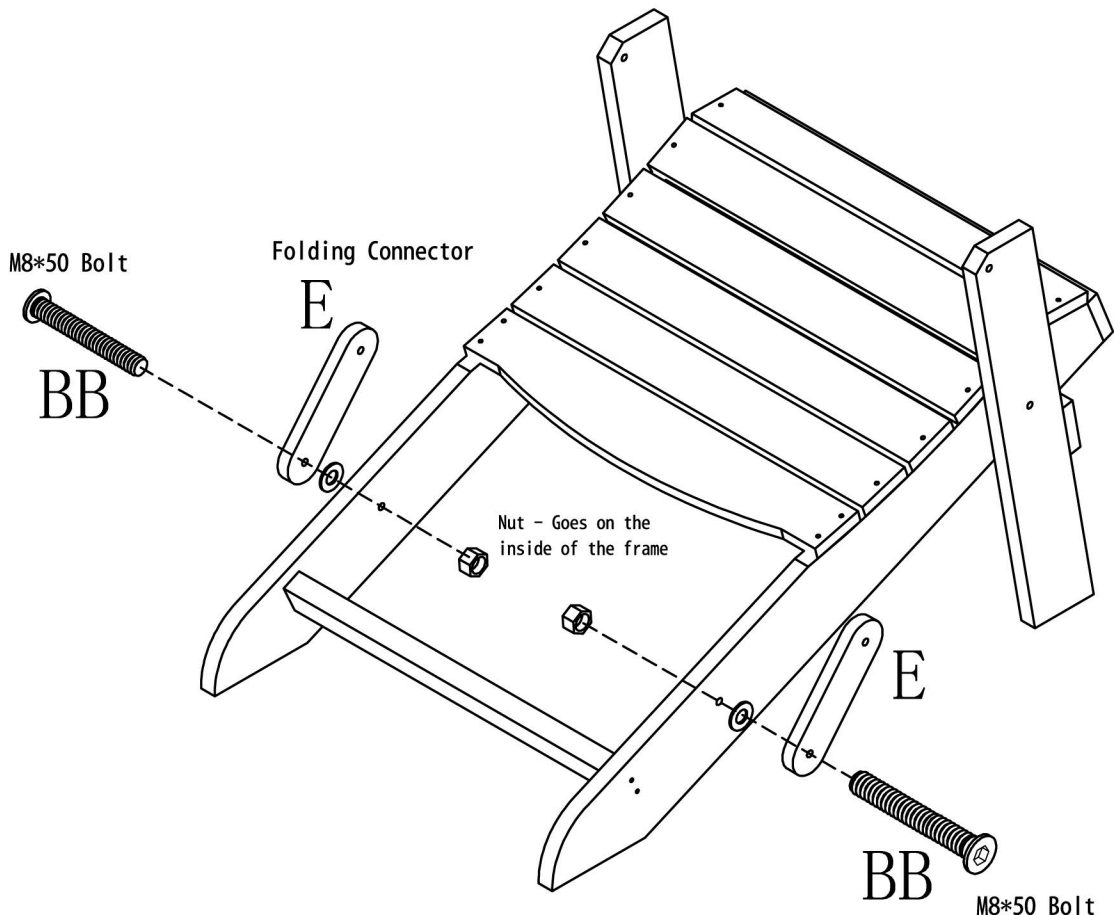

## STEP 5

Attach the Left Arm (Part C) and Right Arm (Part D) to the Legs (Part F) using (2) M8\*50 bolts sets (Part BB). Tighten using the Allen Wrench (Part EE) and Open End Wrench (Part FF).

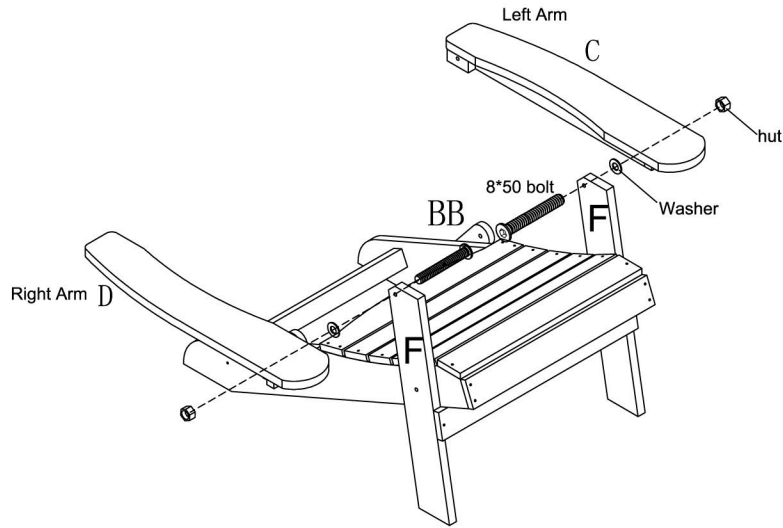

## STEP 6

Attach the Left Arm (Part C) and Right Arm (Part D) to the Backrest (Part A) using (2) M8\*80 bolt sets (Part DD). Tighten using the Allen Wrench (Part EE).

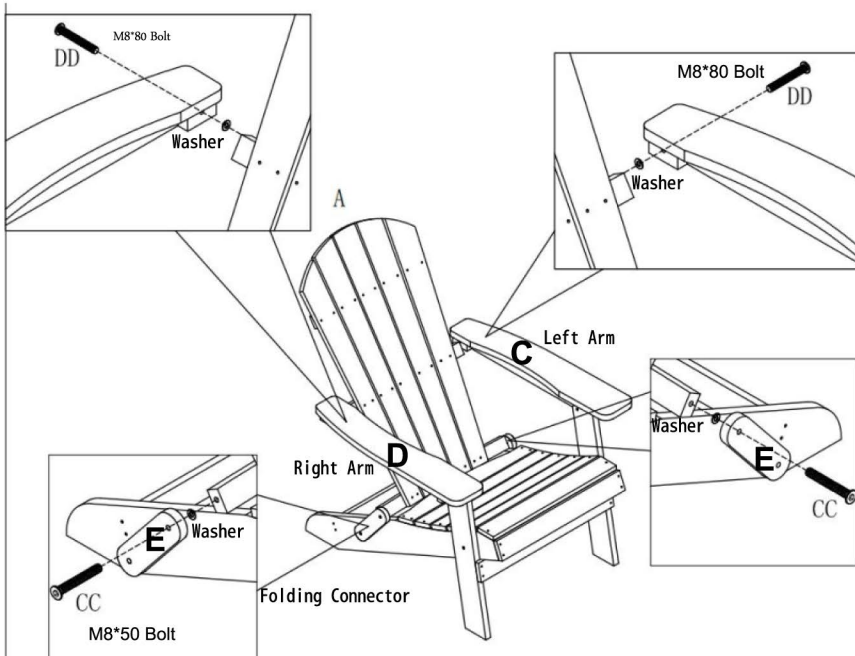

Attach the Folding Connectors (Part E) to the Backrest (Part A) using (2) M8\*50 bolt sets (Part CC). Tighten using the Allen Wrench.

## Quality and Safety Guidelines:

- Please follow the static and dynamic weight capacity limits provided on this item.
- Please use this item on a stable, level surface only. All chair legs should contact the flooring surface when in use. Do not use this item if any instability is detected.
- This chair is not intended for reclined positions. To prevent accidental tipping, do not push backward or forward while seated.
- This item is intended for sitting only, do not climb or stand on this item.
- For product longevity, product safety and product integrity, protect from extended periods of wet weather and store indoors in a dry location.