

Rocking Chair

ASSEMBLY INSTRUCTIONS

Before You Begin:

Please identify all component parts and hardware pieces required before you begin. Carefully remove all of the components from the packaging and set aside for assembly. Assemble on a soft surface to prevent scratching during assembly.

Caution:

Tighten all components securely before use. Failure to do so may result in personal injury.

DO NOT use any sharp objects to open plastic wrapped components as damage to product or components may result.

Warning:



CHOKING HAZARD - Small Parts. Adult Assembly Required.

DO NOT ALLOW CHILDREN TO CLIMB ON FURNITURE

Serious or fatal injuries can occur from furniture tipping over. You must install Tipping Restraint Hardware (where included) to help prevent the unit from tipping and causing accidental injury, instability, death or damage. The tipping restraint is intended only as a safety measure, it is not a substitute for proper adult supervision.

To help prevent furniture from tipping over it must be permanently attached to the wall. Anti-Tip Safety Wall Straps suitable for the unit weight and wall materials (if not included) should be purchased and installed.

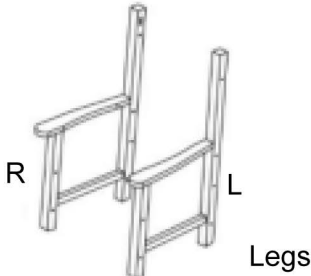
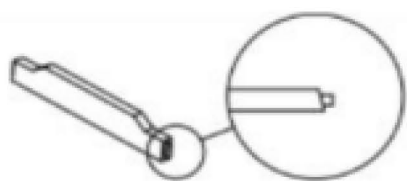
PARTS

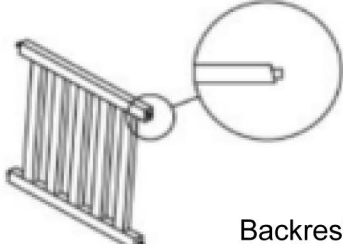
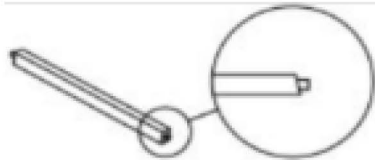
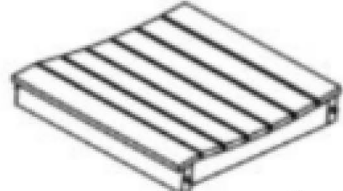
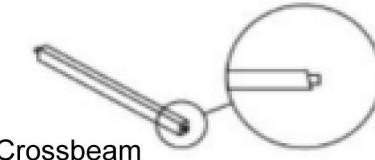

| | | | | | |
|---|---|------|---|---|-----|
| A |  <p>Legs</p> | 2PCS | E |  <p>Backrest Support Slat</p> | 1PC |
| B |  <p>Runners</p> | 2PCS | F |  <p>Backrest</p> | 1PC |
| C |  <p>Crossbeam</p> | 1PC | G |  <p>Seat</p> | 1PC |
| D |  <p>Crossbeam</p> | 1PC | | | |

TOOLS REQUIRED (not included)

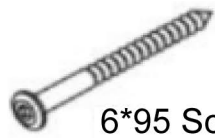
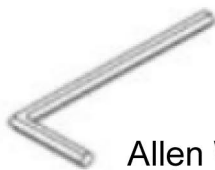

Phillips screwdriver

Hardware Included

| | | | | | |
|----|---|-------|--|---|-----|
| AA |  <p>6*95 Screw</p> | 4PCS | |  <p>Allen Wrench</p> | 1PC |
| BB |  <p>M6*50 Bolt</p> | 12PCS | | | |

***NOTE:DO NOT TIGHTEN ANY BOLTS BEFORE THE UNIT IS PUT TOGETHER.**

STEP 1

Attach the Runners (Part B) to the Legs (Part A) using (4) 6*95 Screws (Part AA) and a Philips Screwdriver.

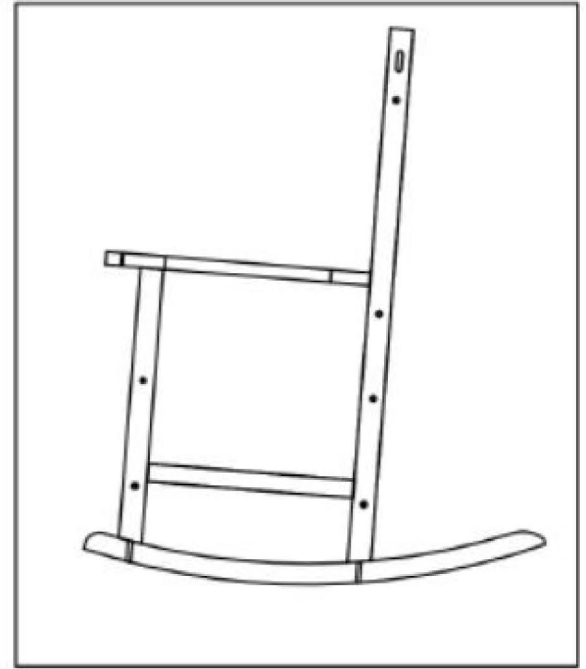
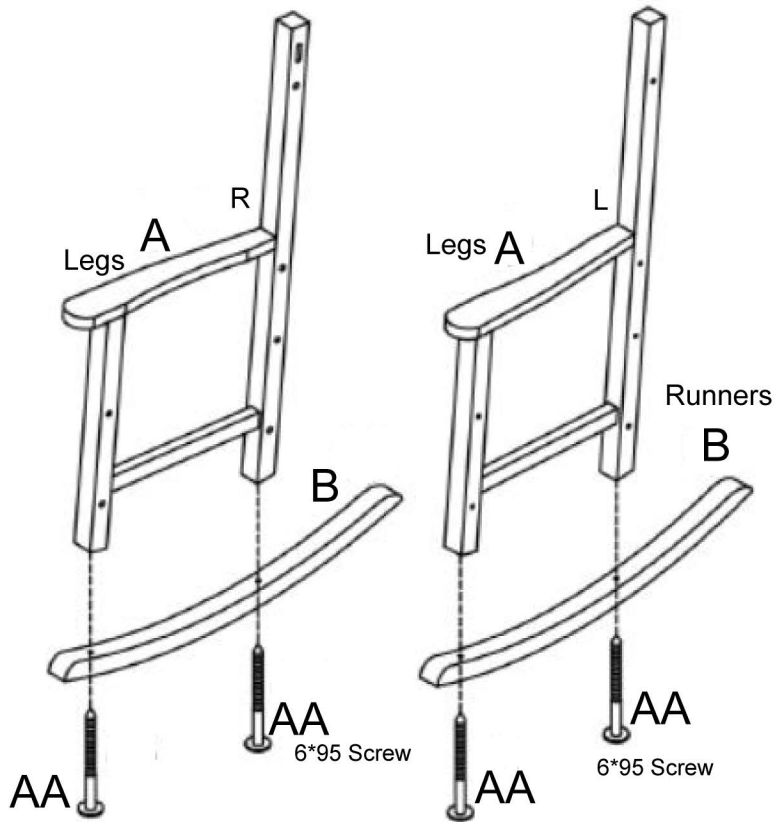

STEP 2

Attach the Backrest Support Slat (Part E) and the Backrest (Part F) to the Leg (Part A) using (2) M6*50 Bolts (Part BB).

Attach the Crossbeam (Part C) and (Part D) to the Leg (Part A) using (2) M6*50 Bolts (Part BB).

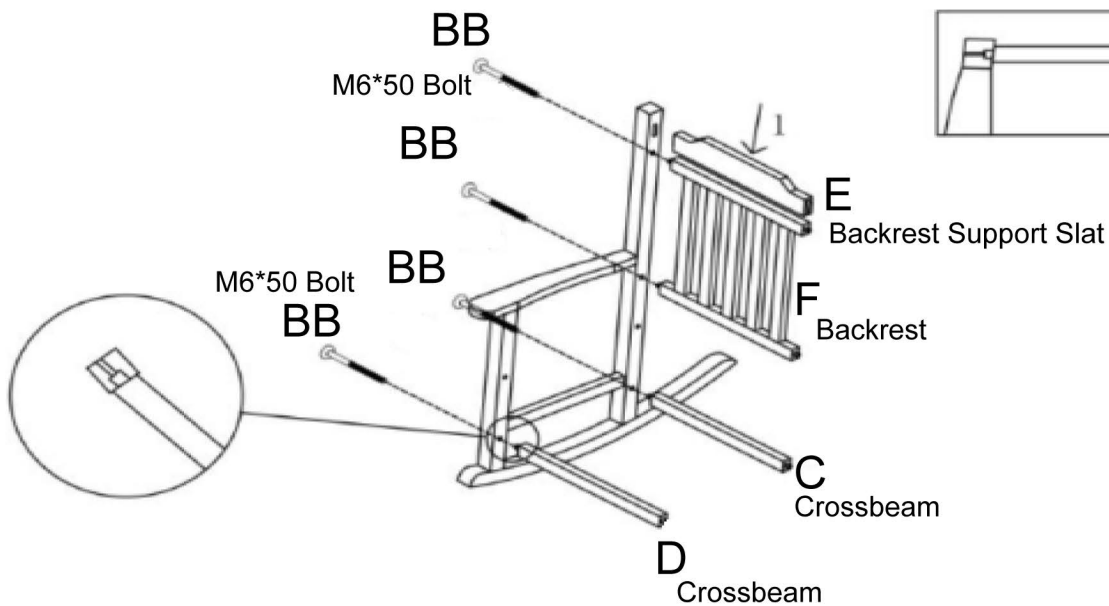

STEP 3

Attach the Seat (Part G) to the Leg (Part A) using (2) M6*50 Bolts (Part BB).

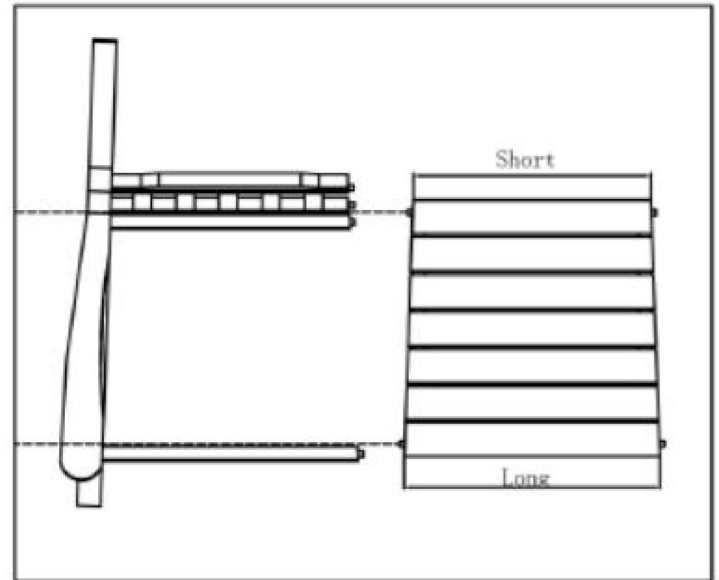
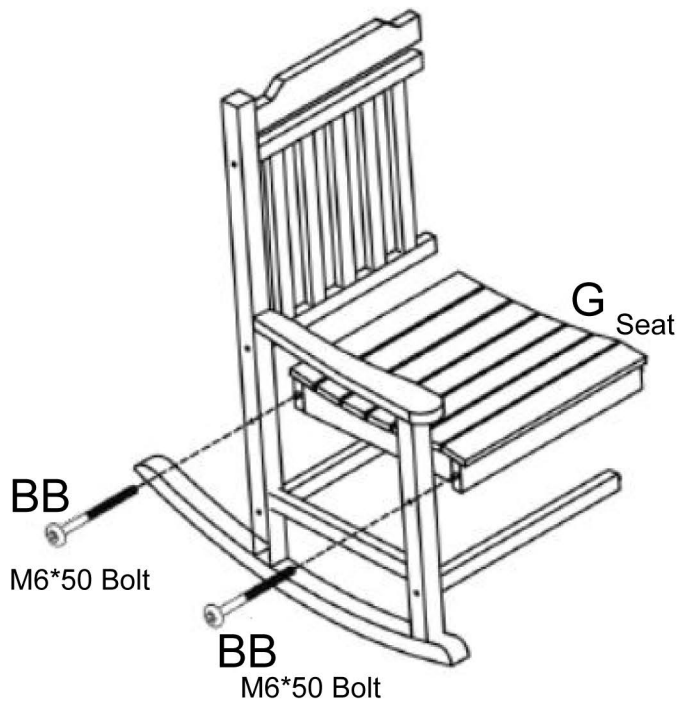

STEP 4

Attach the Seat (Part G) to the leg (Part A) using (2) M6*50 Bolts (Part BB).

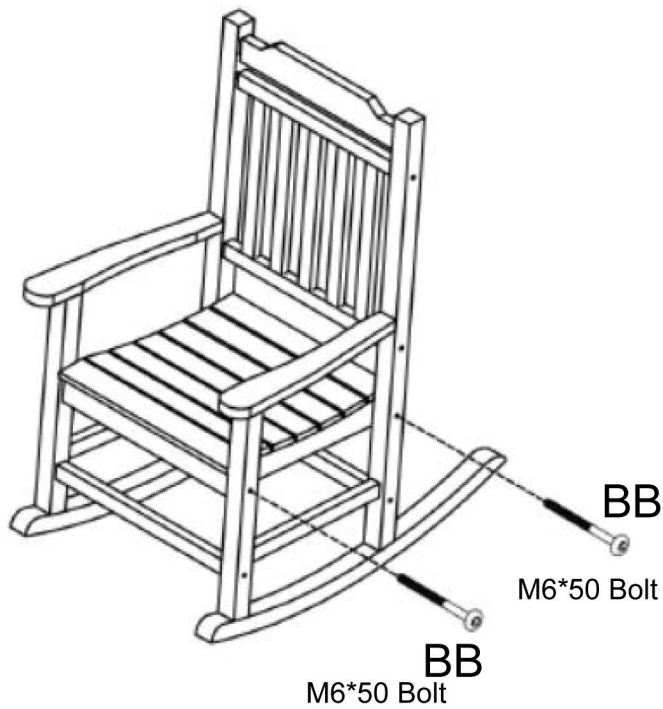

STEP 5

Attach the Backrest (Part F) to the Leg (Part A) using (2) M6*50 Bolts (Part BB).

Attach the Crossbeam (Part C) and (Part D) to the Leg (Part B) using (2) M6*50 Bolts (Part BB).

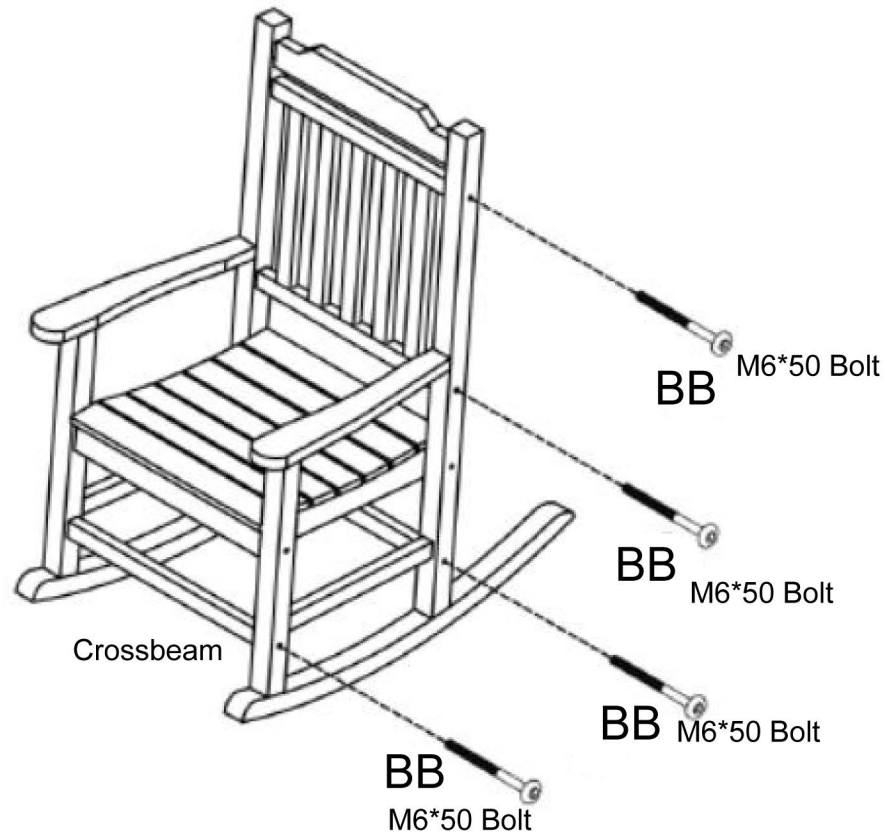

STEP 6

Tighten all bolts.

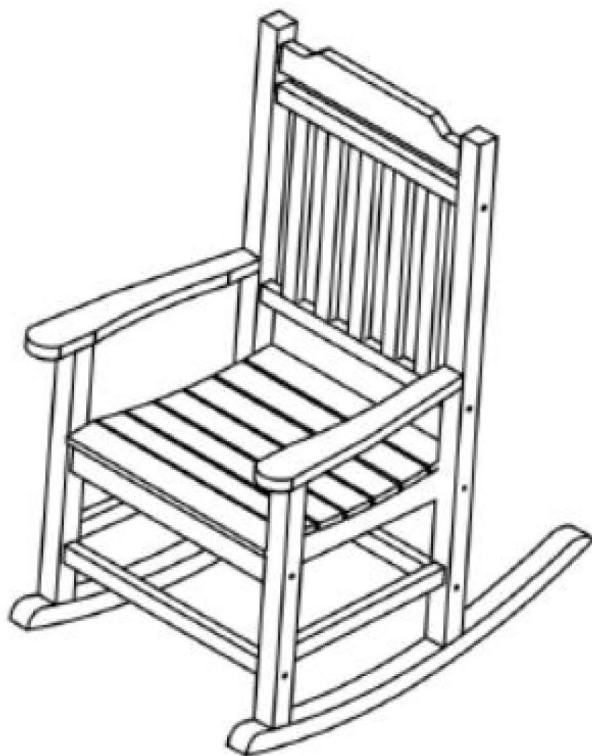

Quality and Safety Guidelines:

- Please follow the static and dynamic weight capacity limits provided on this item.
- Please use this item on a stable, level surface only. All chair legs should contact the flooring surface when in use.
- To prevent pinching or crushing injuries, ensure that the area beneath the curved rockers is clear before the chair is set into motion.
- This chair is intended for gentle rocking motions, do not use excessive force during backward or forward movement to prevent accidental tipping.
- This item is intended for sitting only, do not climb or stand on this item.
- For product longevity, product safety and product integrity, protect from extended periods of wet weather and store indoors in a dry location.