

ROHL MATHESON THERMOSTATIC SHOWER TRIM SET

ML2027LMAPC, ML2027LMPN, ML2027LMSTN

For Thermostatic Valve Rough R1085BO

INSTALLATION INSTRUCTIONS

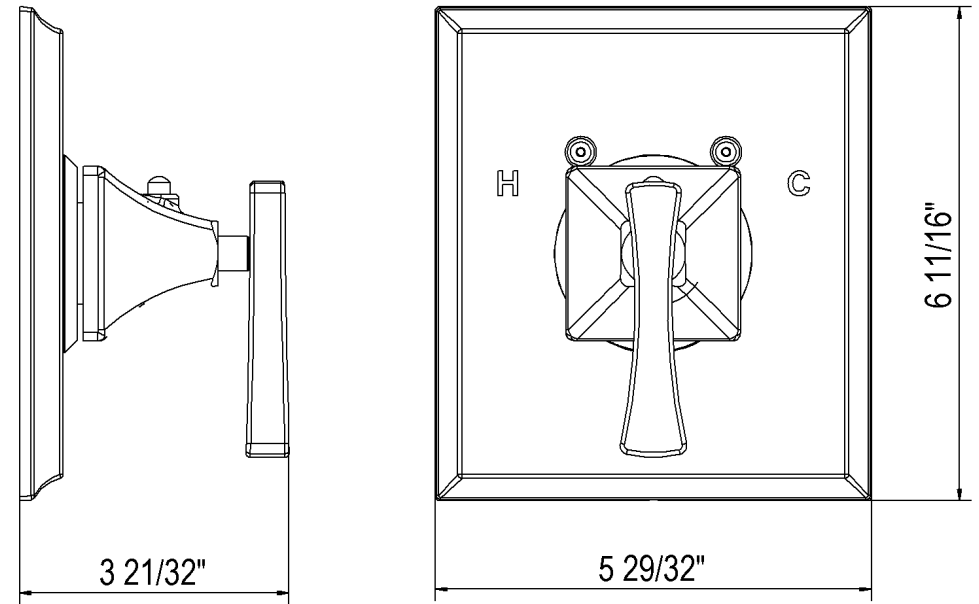

Please leave instructions with the home owner once installed.

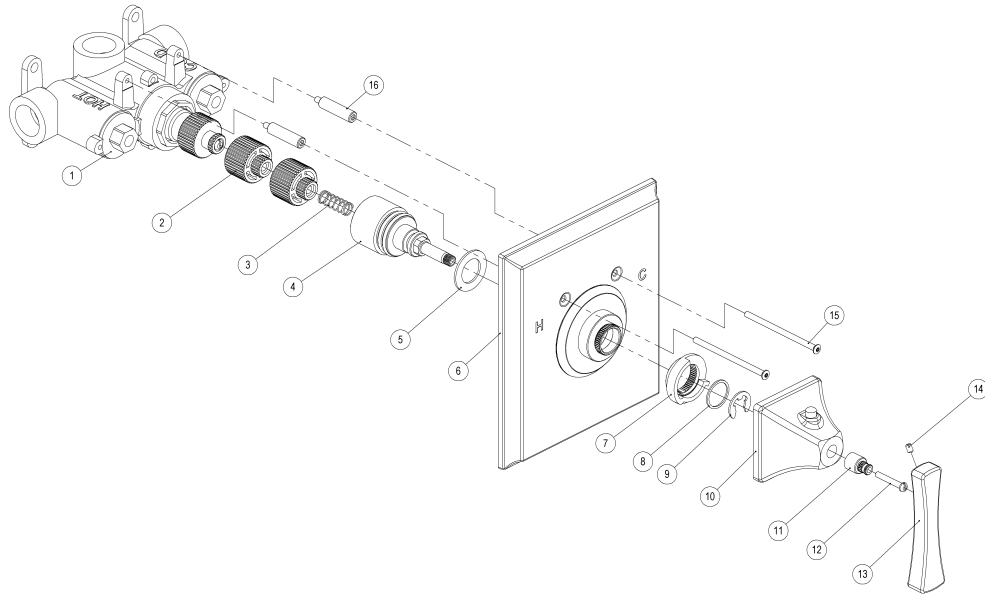

1	THERMOSTATIC VALVE (NOT INCLUDED)
2	ADAPTOR
3	SPRING
4	SPINDLE
5	PLASTIC WASHER
6	FACEPLATE
7	THERMOSTATIC STOP
8	PLASTIC WASHER
9	'C' - RING
10	LEVER ESCUTCHEON
11	LEVER INTERFACE SPACER
12	PAN HEAD SCREW
13	LEVER
14	GRUB SCREW
15	MOUNTING SCREW X 2
16	EXTENSION POLE X 2

Installation Instructions

- Attention Installer: the Thermostatic trim kit is assembled at the factory. The only loose parts are the extension kit parts, #2, #3 and #16 and the mounting screws #15.
- An exploded view is provided for parts #4 through #15.
- Please note: Parts #2, #3 and #16 are optional, if needed.
- #2 is the white nylon extension. There are two. If not needed then discard.
- #3 is a spring that helps retain #2 in the dome assembly. IF not needed, then discard.
- #15 are the face plate screw extensions. If not needed then discard.
- If the parts #2, #3 and #16 are not in the trim kit, then order C7913SET at no charge from ROHL.
- Applying a small bead of silicone on the back of the faceplate #6 is recommended.

Care and Maintenance: After use, wipe down with a soft, dry cloth.

For all chrome plated surfaces clean this product with warm soapy water and then dry with a dry soft cloth.

Nickel plated, satin and Inca brass finishes should be cleaned with a soft cloth and warm water and then dried with a dry soft cloth.

Do not use cream cleaners or cleaning agents containing a corrosive acid or scouring agent including: Softscrub, Comet, Ajax and Bonami, as these may damage the surface of the faucet.

Do not use any spray cleaners with ammonia or alcohol like Windex, 409 or Fantastik.

Any use of unsuitable cleaning agents causing damage to the surface will not be covered by the warranty.

WARRANTY: Warranty is limited lifetime. See ROHL website for details.

(www.rohlhome.com)

A basic in-line filter system is required for the house to protect any debris from entering the water supply line to the house (i.e. due to construction or service work on the street water main).