



3-FUNCTION CLASSIC HANDSHOWER

ROHL Spa Shower Collection

1151/8 (Handshower only with Brass Handle)

1150/8 (Handshower only with Resin Handle)

FEATURES

- Solid brass construction
- 3-function spray patterns
 - Classic Spray
 - Champagne
 - Massage
- 1/2" male connection
- 2.0 GPM
- Anti-calcium components
- Includes ROHL logo on handshower spray face

FINISHES

- Polished Chrome
- Polished Nickel
- Satin Nickel
- Tuscan Brass
- Inca Brass
- Old Iron*

*Old Iron finish only available for 1151/8

WARRANTY

- 2 years on manufacturer defects*

* No Warranty on Tuscan Brass Finish (TCB)

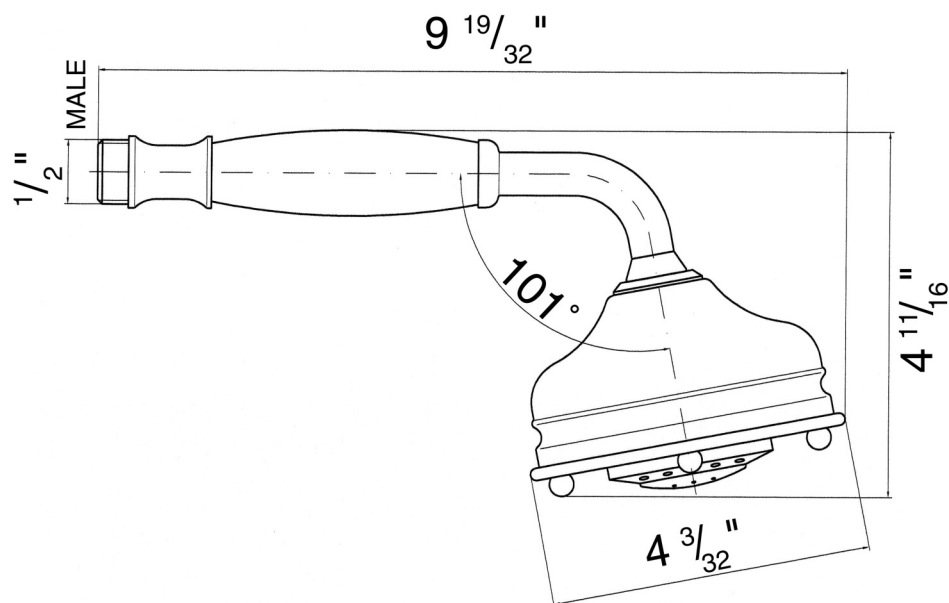



Shower Bar

ROHL Shower Collection

1200 (White resin cap on cross handle)

1201 (Brass cap on cross handle)

FEATURES

- Solid brass construction
- Wall mounting
- 24" total length
- 3/4" diameter bar
- Country style
- Sliding handshower parking bracket

COLORS/FINISHES

- Polished Chrome
- Polished Nickel
- Satin Nickel
- Tuscan Brass
- Inca Brass
- Old Iron*

WARRANTY

- Two Years on Manufacturer Defects*
- *No Warranty on Tuscan Brass Finish

*Old Iron finish only available for 1201

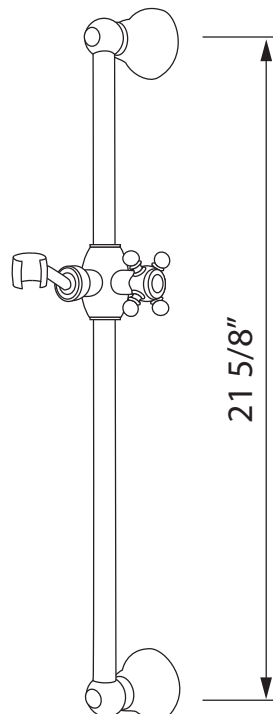



Handshower Wall Outlet

ROHL Shower Collection

1295

FEATURES

- Brass construction
- 1/2" female inlet connection
- 1/2" male outlet connection
- Sliding escutcheon

COLORS/FINISHES

- Polished Chrome
- Polished Nickel
- Satin Nickel
- Tuscan Brass
- Inca Brass
- Old Iron

WARRANTY

- Two Years on Manufacturer Defects*
- * No Warranty on Tuscan Brass Finish (TCB)

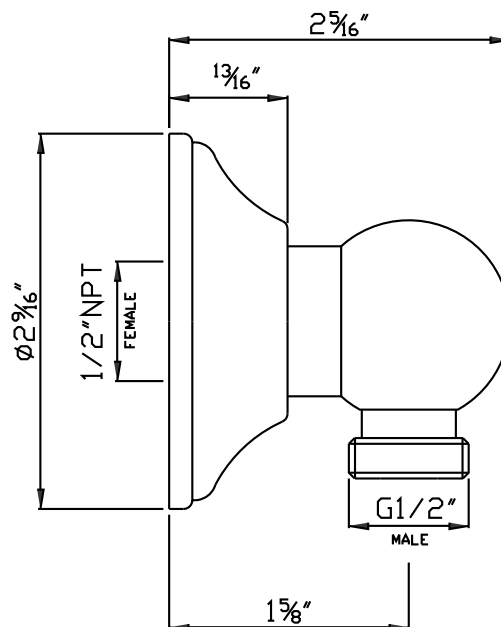



METAL SHOWER HOSE ASSEMBLY

ROHL Spa Shower Collection

16295 (59" hose)

16295/79 (79" hose)

FEATURES

- Brass outer coil
- Double spiral
- PVC lining
- Does not warp or stretch
- 1/2" female connections
- Hose length:
 - 16295 - 59"
 - 16295/79 - 79"

COLOR/FINISH

- Polished Chrome
- Polished Nickel
- Satin Nickel
- Tuscan Brass
- Inca Brass
- Matte Black
- Old Iron *

*Old Iron finish only available for 16295

WARRANTY

- 2-year Limited Warranty**
- ** No warranty on Tuscan Brass

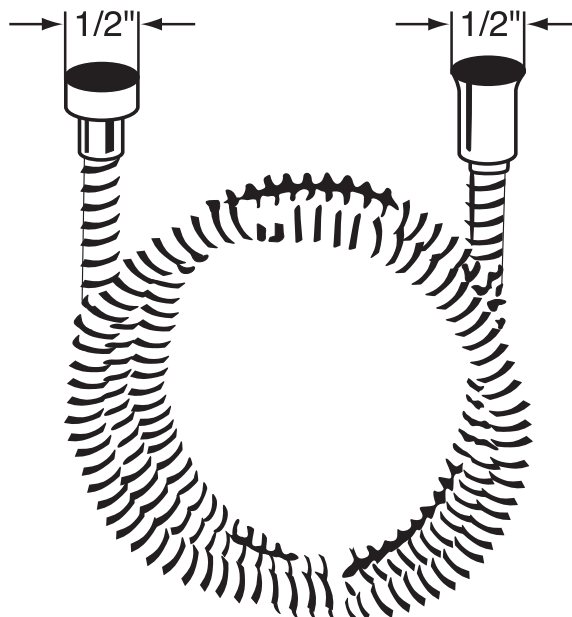



3-Function Showerhead

ROHL Shower Collection

1085/8

FEATURES

- All brass construction
- 3-function spray patterns
 - Classic Spray
 - Champagne
 - Massage
- 1/2" female connection
- 2.0 GPM
- Anti-calcium components

FINISHES

- Polished Chrome
- Polished Nickel
- Satin Nickel
- Tuscan Brass
- Inca Brass
- Old Iron

WARRANTY

- 2 years on manufacturer defects*
- * No Warranty on Tuscan Brass Finish (TCB)

1085/8

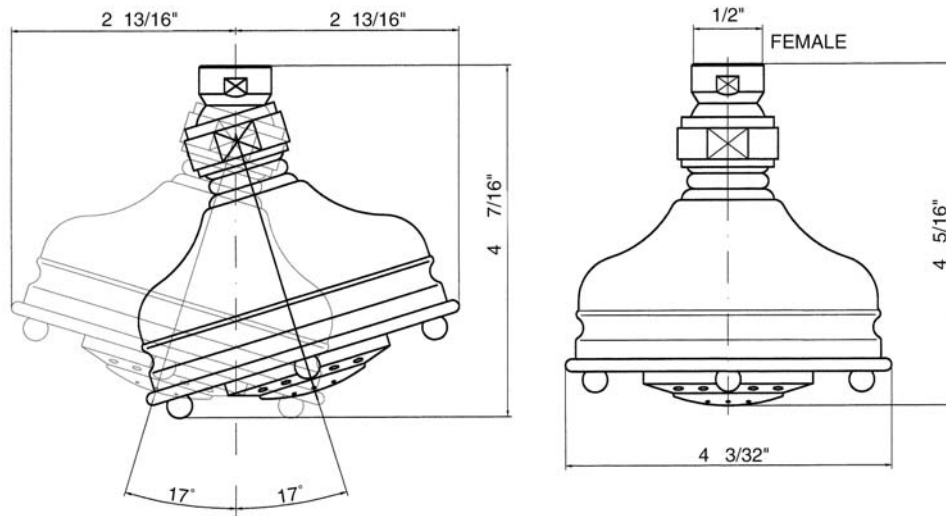

INSTRUCTION MANUAL
MANUEL D'INSTRUCTIONS
MANUAL DE INSTRUCCIONES

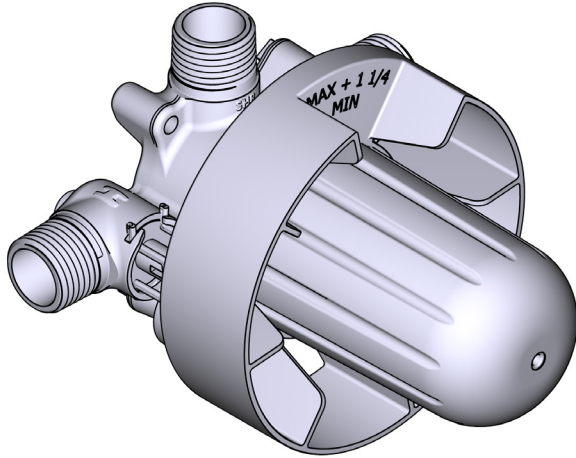

2-Way Type T/P (Thermostatic/Pressure Balance)
Coaxial Valve Rough

Brut de valve 2 voies coaxiale Type T/P
(thermo/pression équilibrée)

Válvula coaxial de dos vías tipo T/P
(termostática/equilibrio de presión)

HELPFUL TOOLS

For safety and ease of installation, the use of these helpful tools is recommended.

OUTILS UTILES

Pour des raisons de sécurité et de facilité d'installation, l'utilisation de ces outils utiles est recommandée.

HERRAMIENTAS ÚTILES

Por seguridad y facilidad de instalación, se recomienda el uso de estas útiles herramientas.

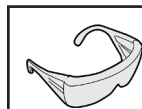

Safety Glasses
Lunettes de sécurité
Gafas de seguridad



Thread Seal Tape
Ruban d'étanchéité pour
joints filetés
Cinta de teflón

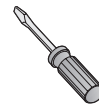

Flathead Screwdriver
Destornillador de punta chata
Tournevis à tête plate

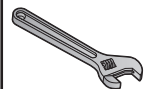

Adjustable Wrench
Clé ajustable
Llave ajustable

Parts List

- A. Valve
- B. Valve Cover
- C. Plaster Ground
- D. Service Valve

Note: Not a stop valve (may not shut off water completely)

Lista de piezas

- A. Válvula
- B. Couvercle de la valve
- C. Gabarit d'installation
- D. Valve de service

Remarque : Il ne s'agit pas d'une valve d'arrêt (elle ne peut couper entièrement l'alimentation en eau).

Liste des pièces

- A. Válvula
- B. Cubierta de la válvula
- C. Protector de válvula
- D. Válvula de servicio

Nota: No es una válvula de cierre (podría no cerrar el suministro de agua completamente)

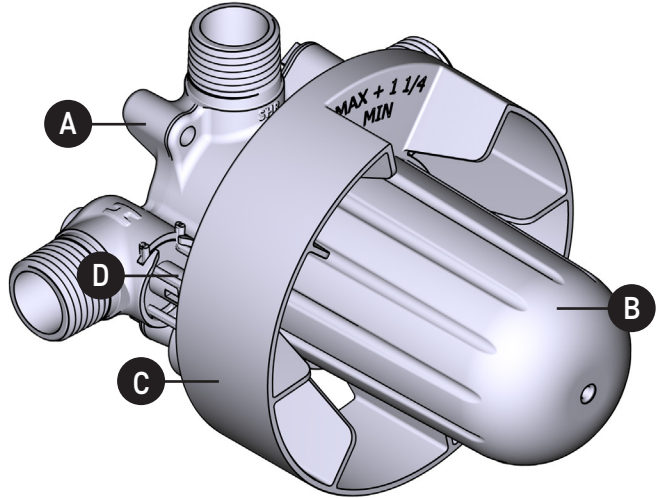

Standard Wall / Mur standard / Pared estándar

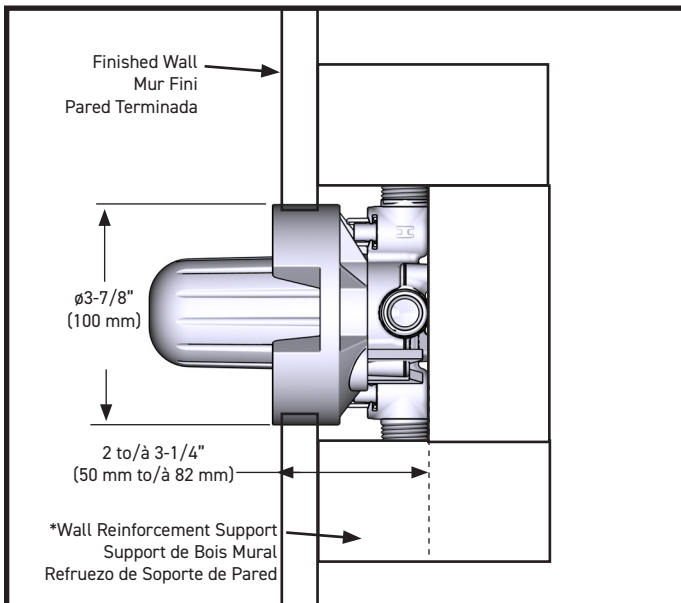

Acrylic Wall/Mur en Acrylique/Pared de Acrílico

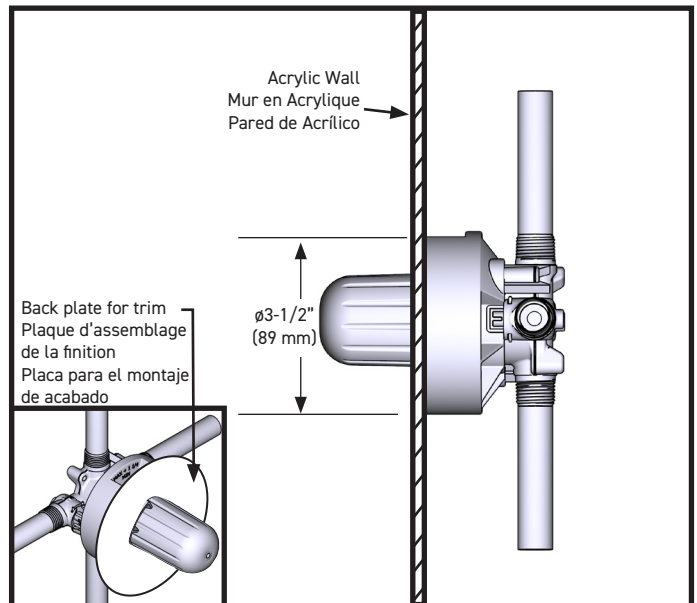

CAUTION – TIPS FOR REMOVAL OF OLD FAUCET:

Always turn water supply OFF before removing existing faucet or disassembling the valve. Open faucet handle to relieve water pressure and ensure that complete water shut-off has been accomplished.

ATTENTION – CONSEILS POUR LE RETRAIT DE L'ANCIEN ROBINET:

Toujours couper l'alimentation en eau avant de retirer ou de démonter le robinet. Ouvrir le robinet pour libérer la pression d'eau et pour s'assurer que l'alimentation en eau a bien été coupée.

PRECAUCIÓN – CONSEJOS PARA CAMBIAR LA LLAVE MEZCLADORA:

Siempre CIERRE la toma de agua antes de quitar la llave existente o desmontar la válvula. Abra la llave para liberar la presión, y asegúrese de que esté bien cerrada el agua.

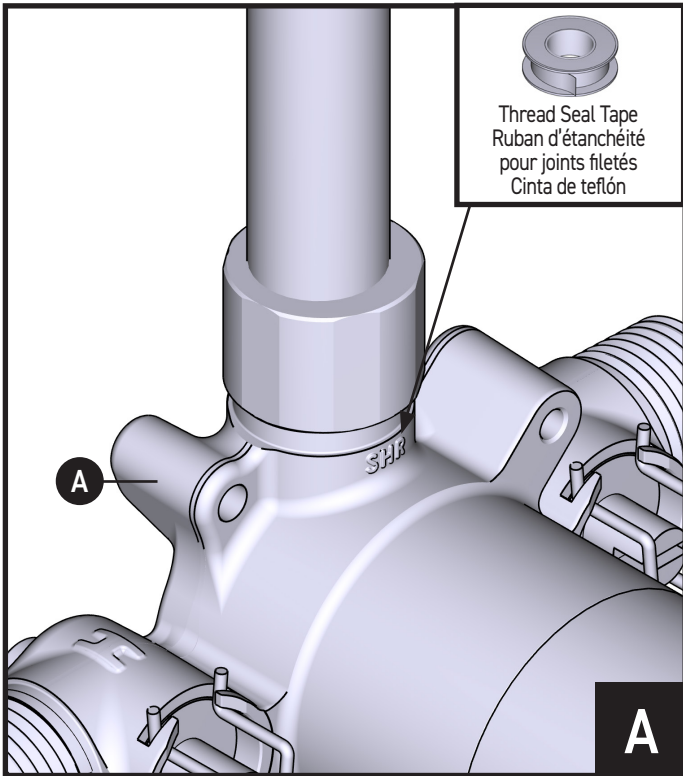

1. Apply 15-20 turns of Thread Seal Tape to threads of Valve **(A)**.
 2. Installation shows Male NPT type. Tighten with wrench.
1. Faire de 15 à 20 tours avec le ruban pour joint fileté autour des filets de la valve **(A)**.
 2. L'illustration montre une installation effectuée au moyen d'un raccord mâle de type NPT. Serrer le tout avec une clé.
1. Aplique 15-20 vueltas de cinta de teflón a la rosca de la válvula **(A)**.
 2. La instalación muestra una conexión macho de tipo NPT. Apriete con una llave.

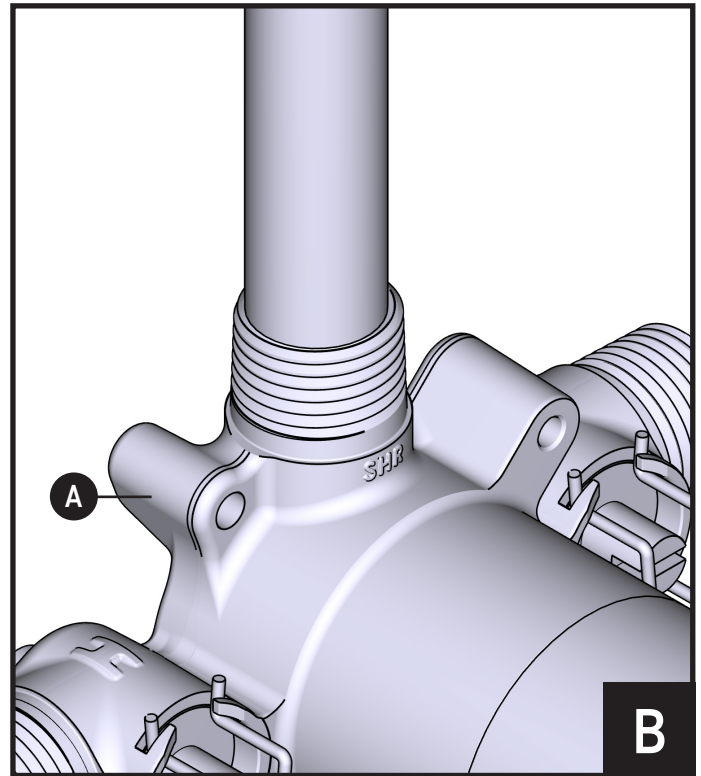

1. Connect pipes to Valve **(A)**. Installation shows soldering.
1. Raccorder les tuyaux à la valve **(A)**. L'illustration montre le résultat d'une installation effectuée au moyen d'un brasage.
1. Conecte la tubería a la válvula **(A)**. La instalación muestra una soldadura.

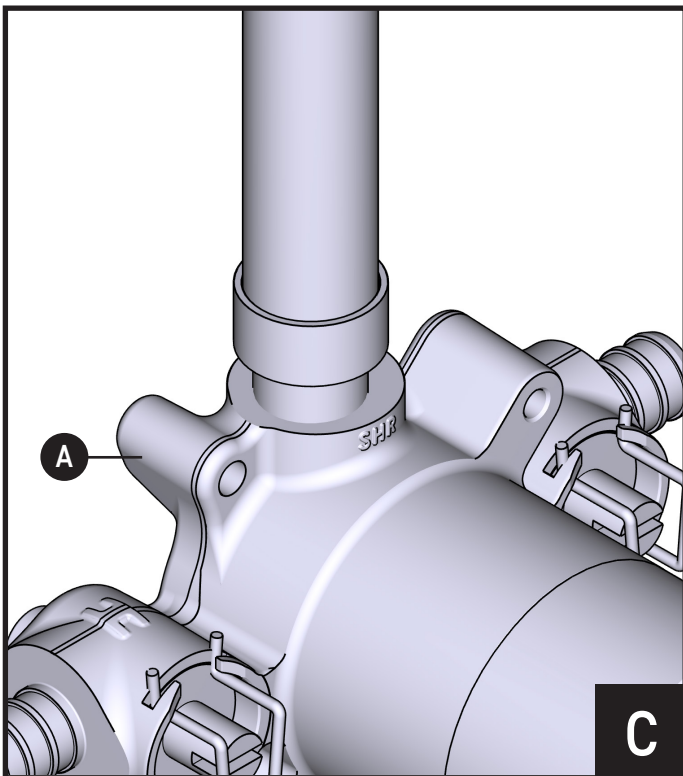

1. Connect pipes to Valve **(A)**. Installation shows PEX.
1. Raccorder les tuyaux à la valve **(A)**. L'illustration montre une installation effectuée au moyen d'un raccord PEX.
1. Conecte la tubería a la válvula **(A)**. La instalación muestra una conexión PEX.

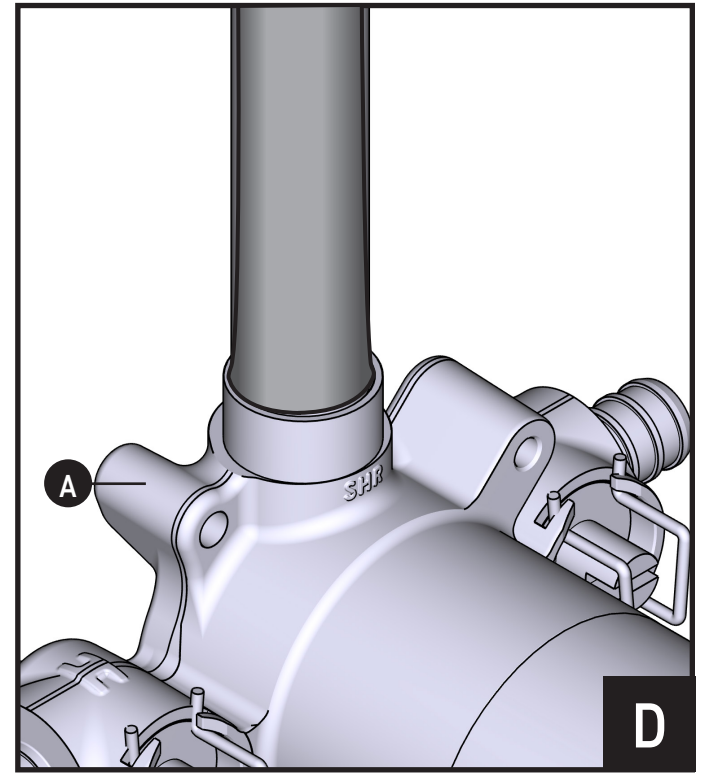

1. Connect pipes to Valve **(A)**. Installation shows CPEX (cold expansion PEX).
1. Raccorder les tuyaux à la valve **(A)**. L'illustration montre une installation effectuée au moyen d'un raccord CPEX (raccord de dilatation à froid PEX).
1. Conecte la tubería a la válvula **(A)**. La instalación muestra una conexión CPEX (con dilatación en frío PEX).

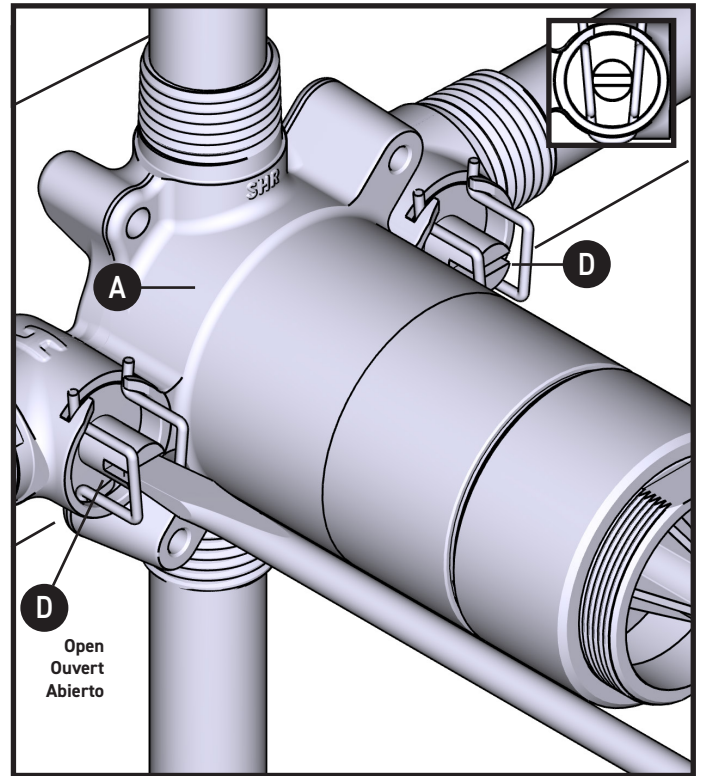
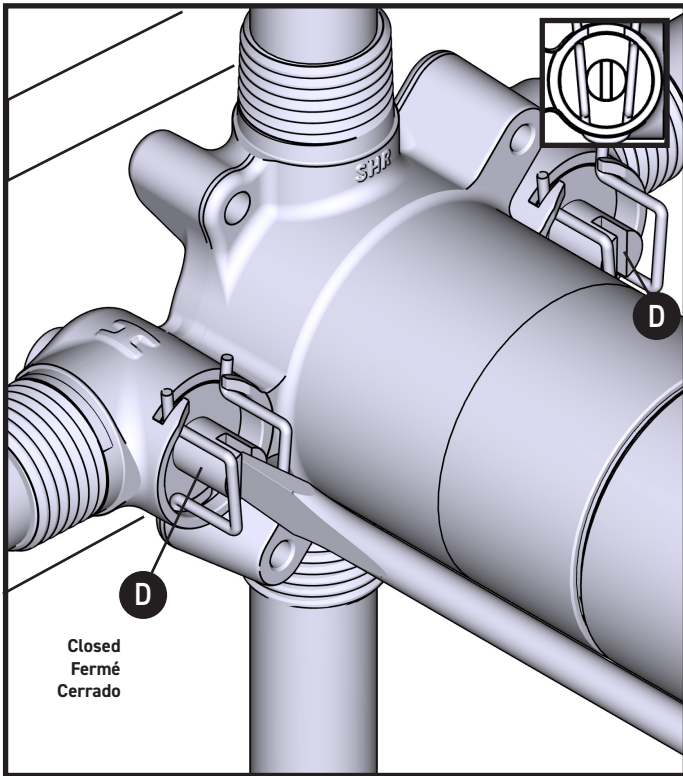

1. Using a flathead screwdriver, rotate the Service Valves (D) to the open position. (Illustration shown is the closed position.)
1. À l'aide d'un tournevis à tête plate, en faisant pivoter les valves de service (D), les placer à la position « ouverte ». (Dans l'illustration ci-dessus, les valves sont à la position « fermée ».)
1. Con un destornillador de punta plana, gire las válvulas de servicio (D) a la posición abierta. (La ilustración que se muestra está en posición cerrada).

1. Ensure Service Valves (D) are now in the open position as illustrated.
1. S'assurer que les valves de service (D) se trouvent maintenant dans la position « ouverte », comme illustré ci-dessus.
1. Asegúrese de que las válvulas de servicio (D) estén ahora en la posición abierta como se muestra.

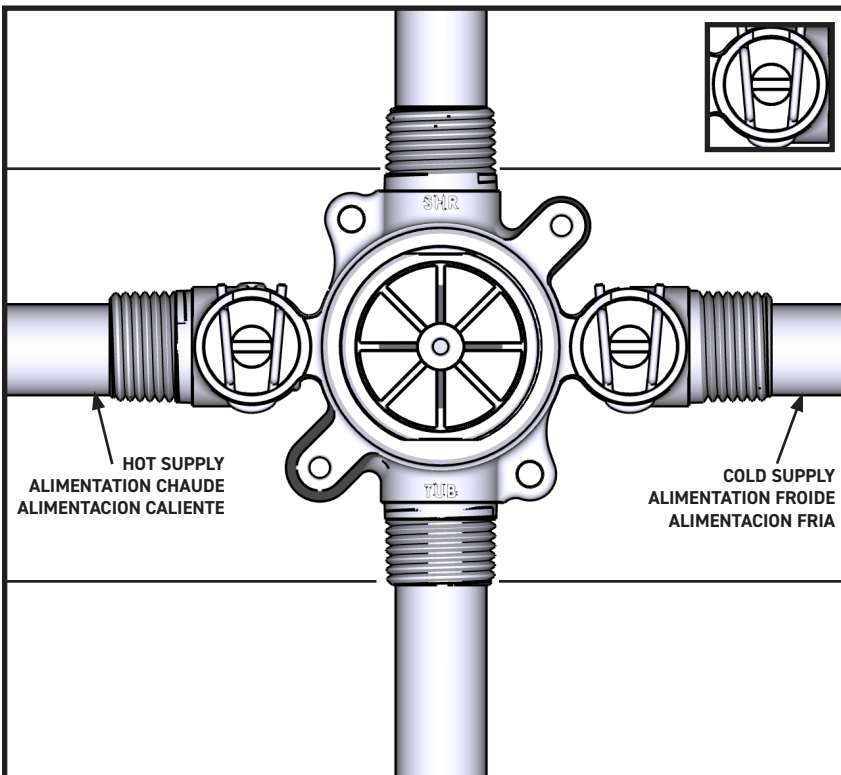

1. Check for leaks. **Cap outlets to keep under pressure.**
1. S'assurer qu'il n'y a aucune fuite. **Bloquer les sorties pour garder sous pression.**
1. Verifique que no haya fugas. **Tape las salidas para mantener baja presión.**

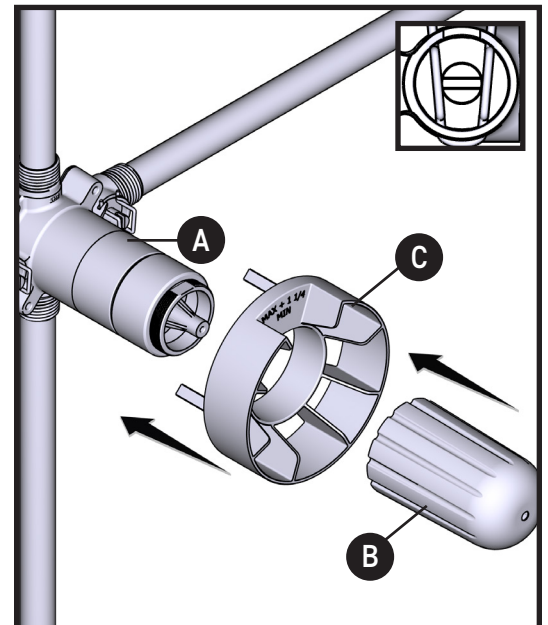

1. Install Plaster Ground (C) and Valve Cover (B) onto Valve (A).
1. Installer le gabarit d'installation (C) et le couvercle de la valve (B) sur la valve (A).
1. Instale el protector de válvula (C) y la cubierta de la válvula (B) en la válvula (A).

Standard Wall
Mur standard
Pared estándar

Ø3-7/8" (100mm)

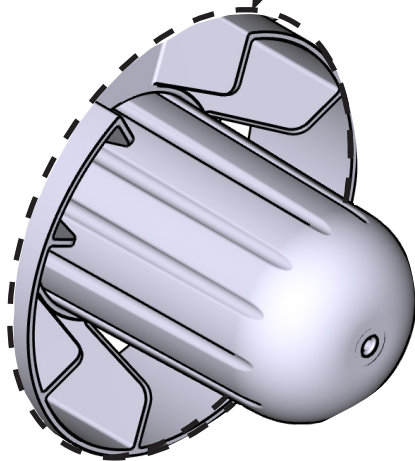

Acrylic Wall
Mur en Acrylique
Pared de Acrílico

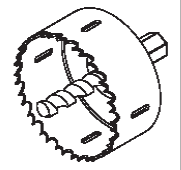

Ø3-1/2" (89mm)

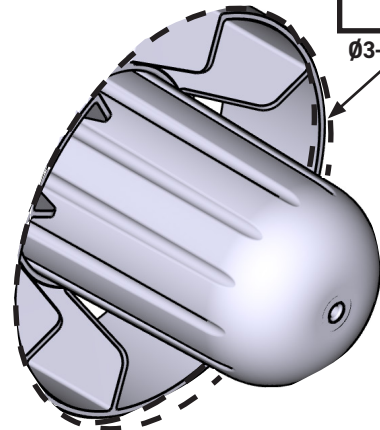

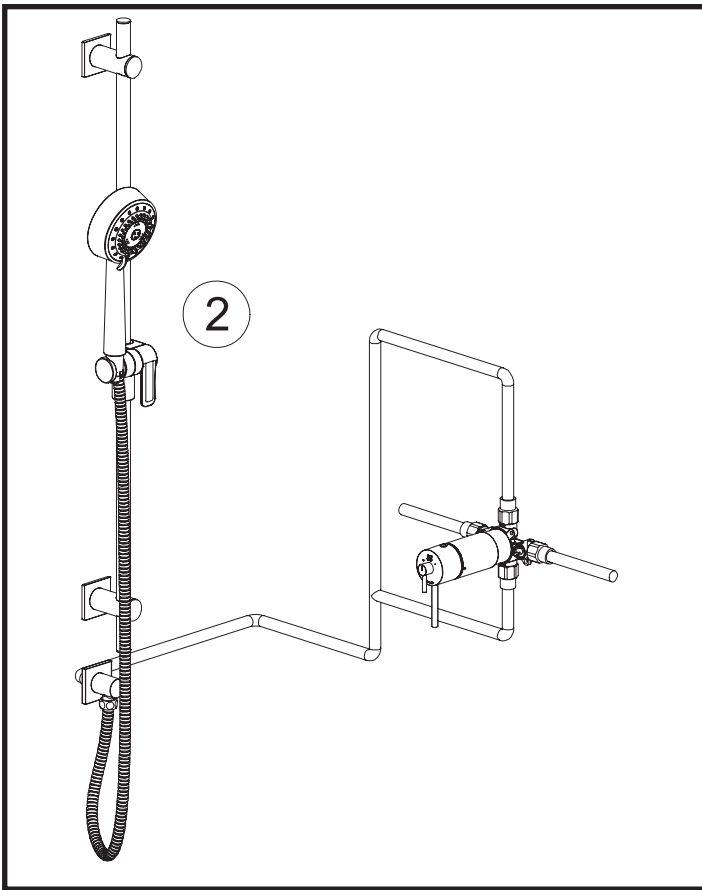

Installation A / Installation A / Instalación A

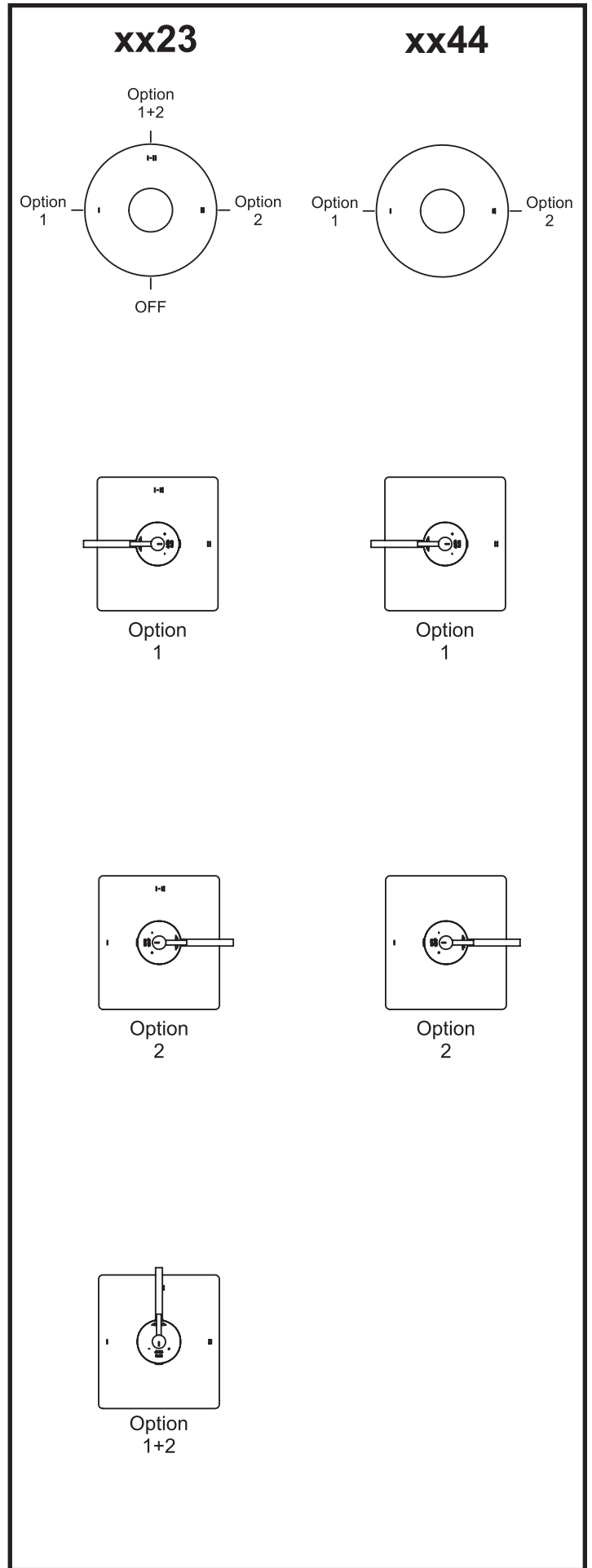
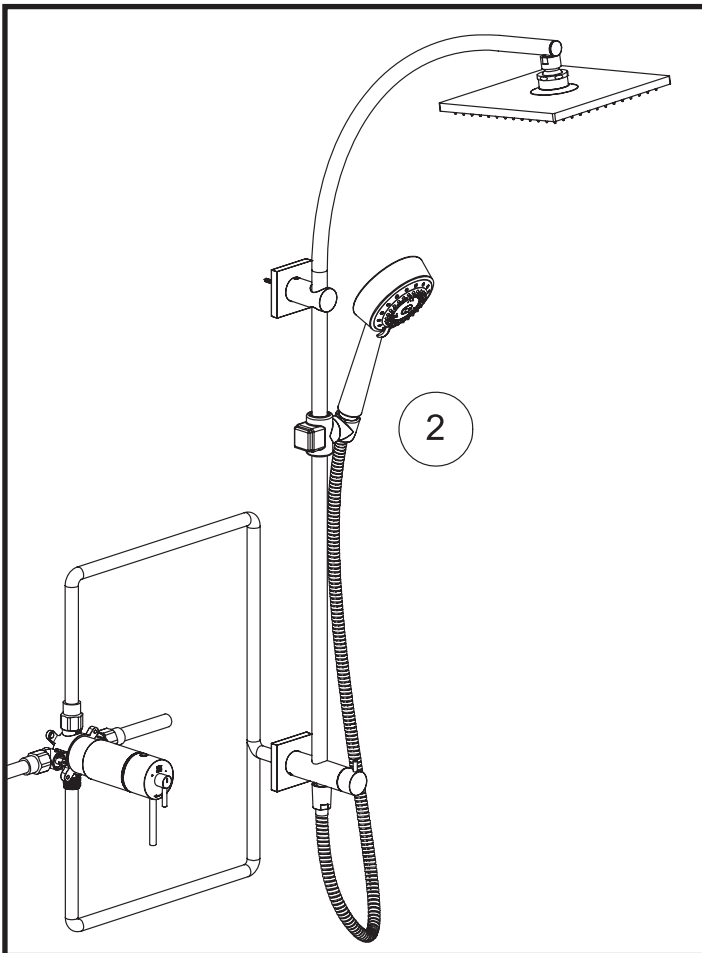

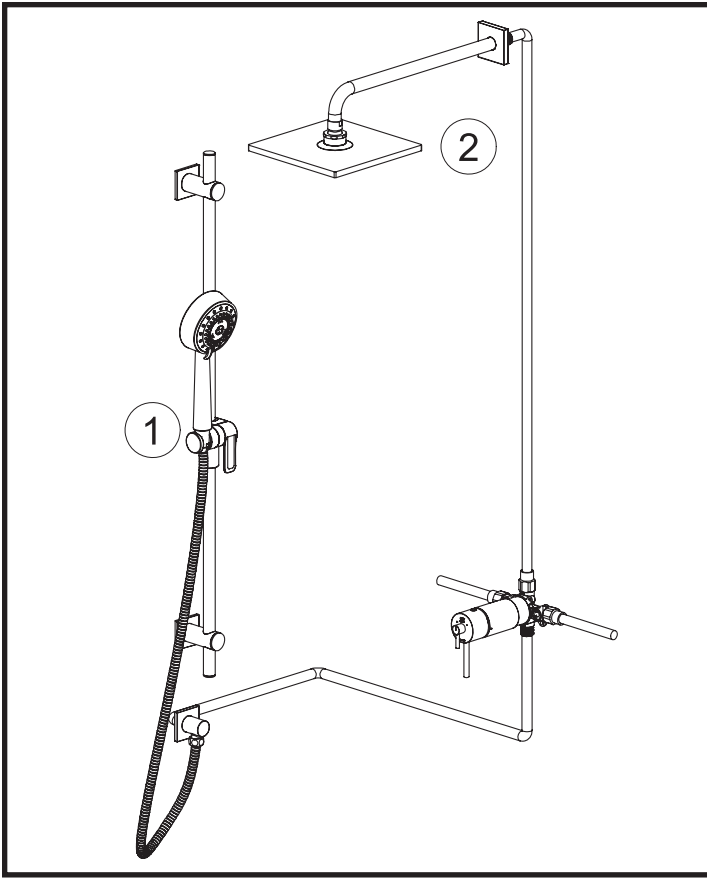

Installation A / Installation A / Instalación A

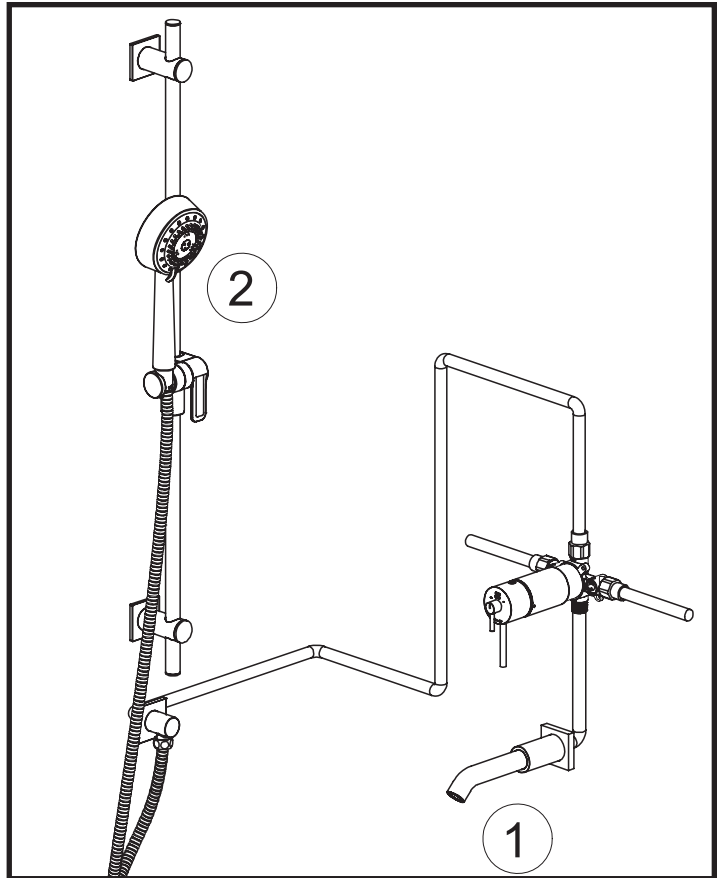

Installation A / Installation A / Instalación A



LIMITED WARRANTY GARANTIE LIMITÉE GARANTÍA LIMITADA

Most products or parts carry "Limited Warranties" against manufacturing defects.
For US Customers please visit houseofrohl.com/support and for Canadian customers please visit riobel.ca
for complete product and finish warranty.

La plupart des produits ou pièces comprend des «garanties limitées» contre les défauts de fabrication. Pour les clients des États-Unis : veuillez consulter houseofrohl.com/support; Pour les clients du Canada : veuillez consulter riobel.ca pour connaître les conditions complètes de la garantie des produits et finis.

La mayoría de los productos o piezas presentan "Garantías limitadas" contra defectos de fabricación. La mayoría de los productos o piezas cuentan con "Garantías Limitadas" por defectos de fabricación. A los clientes en EE. UU. se les recomienda visitar houseofrohl.com/support y a los clientes en Canadá, riobel.ca, para consultar las condiciones completas de la garantía de los productos y acabados.

FINISH CARE & MAINTENANCE ENTRETIEN DE VOTRE FINI CUIDADO Y MANTENIMIENTO DEL ACABADO

The finishing touch on every product is its exquisite surface. Great care has been taken to ensure that the final step in the manufacturing - whether it is a sink, faucet, fitting or an accessory - delivers perfection. Like any quality item, no matter how durable, care should be taken when cleaning and maintaining these finishes. For US Customers please visit houseofrohl.com/support and for Canadian customers please visit riobel.ca for complete finish care and cleaning instructions for your particular finish.

Ce qui distingue nos robinets des autres produits, c'est leur surface d'une beauté exceptionnelle. Un grand soin a été pris pour que la dernière étape de la fabrication - que ce soit pour un évier, un robinet, une composante ou un accessoire - soit fait à la perfection. Comme pour tout article de grande qualité, quelque soit sa durabilité, des précautions doivent être prises lors du nettoyage et de l'entretien des finis. Pour les clients des États-Unis : veuillez consulter houseofrohl.com/support; Pour les clients du Canada : veuillez consulter riobel.ca pour connaître les instructions complètes d'entretien et nettoyage des finis.

El toque final de todo producto es su exquisita superficie. Se ha tenido sumo cuidado para asegurar que el último paso de la fabricación - ya sea de un fregadero, una mezcladora, un herraje o un accesorio - tenga como resultado la perfección. Como con cualquier artículo de calidad, no importa cuán duradero, se debe tener ciertos cuidados al limpiar y mantener estos acabados. A los clientes en EE. UU. se les recomienda visitar houseofrohl.com/support y a los clientes en Canadá, riobel.ca, para ver las instrucciones completas de cuidado y mantenimiento de su acabado particular.

CUSTOMER CARE SERVICE À LA CLIENTÈLE ATENCIÓN AL CLIENTE

The House of Rohl® Customer Care Team is committed to efficiently serve and support; and to do so with respect, honesty, and genuineness. We will passionately work together to always exceed our customers' expectations. We strive to delight and surprise our customers, as well as our business partners. To contact one of our Customer Care Team members:

L'équipe du Service à la clientèle de House of Rohl® s'engage à servir et à soutenir nos clients de manière efficace, respectueuse, honnête et authentique. Nous travaillons avec acharnement pour toujours dépasser les attentes de nos clients afin de les ravir et de surprendre, ainsi que celles de nos partenaires d'affaires. Pour contacter le département du Service à la clientèle :

El equipo de Atención al Cliente de House of Rohl® tiene el compromiso de atender y apoyar eficientemente, y de hacerlo con respeto, honestidad y autenticidad. Juntos trabajaremos con entusiasmo para superar siempre las expectativas de nuestros clientes. Nos esforzamos por sorprender agradablemente tanto a nuestros clientes como a nuestros socios comerciales. Para ponerse en contacto con los miembros de nuestro equipo de Atención al Cliente:

U.S.A.
HOUSEOFROHL.COM
1-800-777-9762

QUEBEC / WEST CANADA / ATLANTIC CANADA
HOUSEOFROHL.CA
1-866-473-8442

ONTARIO
HOUSEOFROHL.CA
1-888-287-5354

A DISTINCTIVE MEMBER OF THE HOUSE OF ROHL
UN MEMBRE DISTINCTIF DE HOUSE OF ROHL
MIEMBRO DISTINTIVO DE LA FAMILIA HOUSE OF ROHL



Wall Mounted Shower Arm

Rohl Shower Collection

1455/6 (6" Shower Arm)

1455/12 (12" Shower Arm)

1455/20 (20" Shower Arm)

FEATURES

- 1/2" male inlet, 1/2" male outlet
- Brass construction
- Sliding escutcheon
- Modern style escutcheon available, order ROGSCO14

COLORS/FINISHES

- Polished Chrome
- Polished Nickel
- Satin Nickel
- Tuscan Brass
- Inca Brass
- Old Iron*

*Old Iron finish not available for 1455/6

WARRANTY

- 2 Years on manufacturers defects*
- * No Warranty on Tuscan Brass Finish (TCB)

1455/6

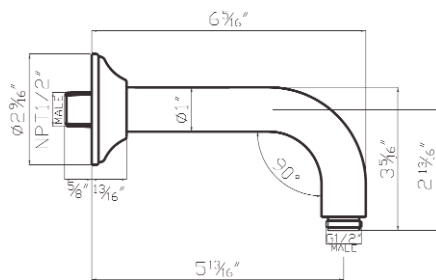

1455/12

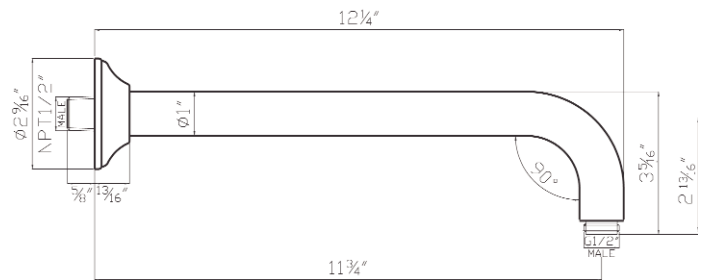

1455/20

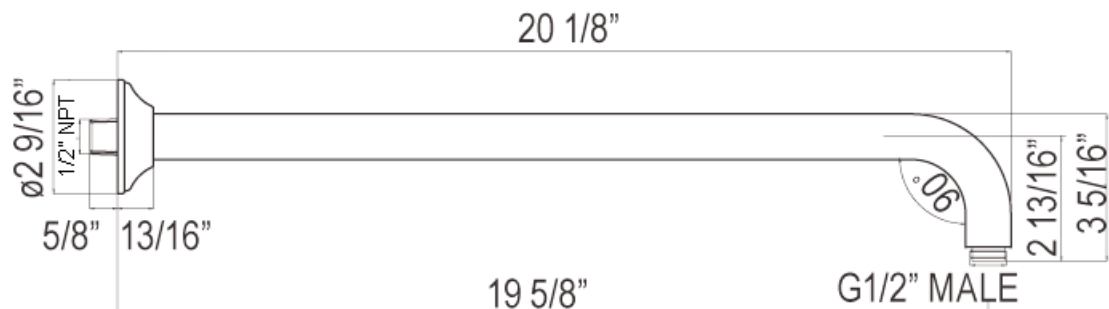

ROHL

Authentic Luxury for Kitchen and Bath®

www.rohlhome.com



BORDANO ANTI-CAL SHOWERHEAD

ROHL Shower

- 1017/8 (5" Showerhead)
- 1027/8 (6" Showerhead)
- 1037/8 (8" Showerhead) (shown)
- 1047/8 (12" Showerhead)

FEATURES

- Single-function Rain showerhead
- Flexible calcium resistant nozzles on spray face allow for easy removal of hard water build-up
- 1/2" female inlet with swivel connection
- Serviceable faceplate except 1037/8
- Flow rate 2.0 GPM
- Swivel ball replacement part #: 1590/8 (FINISH)
- Meets EPA WaterSense® criteria to conserve water without sacrificing performance

COLORS/FINISHES

- Polished Chrome
- Polished Nickel
- Satin Nickel
- Tuscan Brass
- Inca Brass
- Old Iron*

WARRANTY

- 2 years on manufacturer defects*
- *No warranty for Tuscan Brass (TCB)

*Old Iron only available on the 1037/8

1017/8 (5")

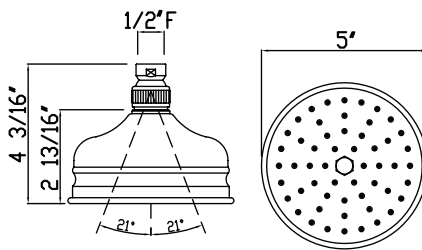

1027/8 (6")

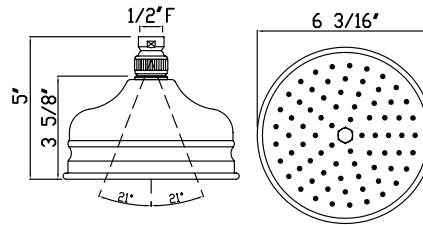

1037/8 (8")

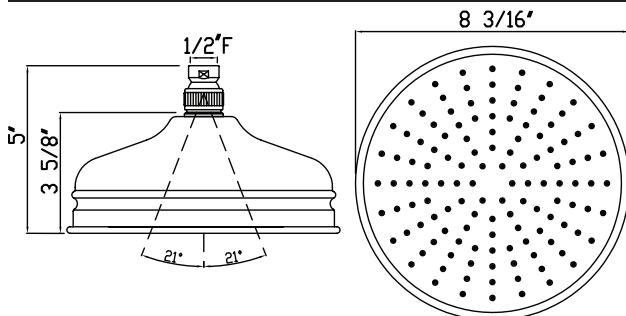

1047/8 (12")

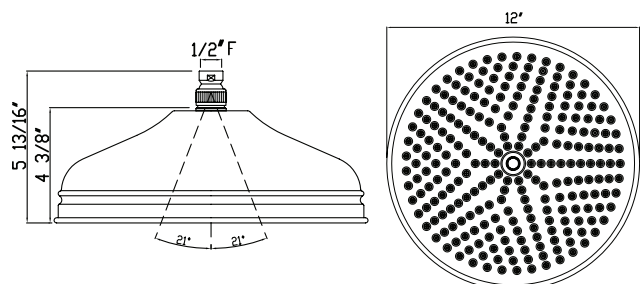

Consult your local ROHL showroom for additional information and specifications. For complete warranty details and a list of showrooms, go to www.rohlhome.com.



SPECIFICATIONS

DESCRIPTION

- Combines both thermostatic and pressure balance technologies
- "Set it and forget it" temperature control
- Temperature and volume control with diverter
- 2 dedicated functions and 1 shared function
- Rough-in valve sold separately:
 - Order R23 therm & pressure balance rough-in valve
 - 1-1/4" R23 extension kit available, order EXT23KIT114
 - 3/4" R23 extension kit available, order EXT23KIT34

CARTRIDGE

- 0-925 (Included)

WARRANTY

- Most products or parts carry "Limited Warranties" against manufacturing defects. For US customers please visit houseofrohl.com/support and for Canadian customers please visit houseofrohl.ca/support for complete product and finish warranty.

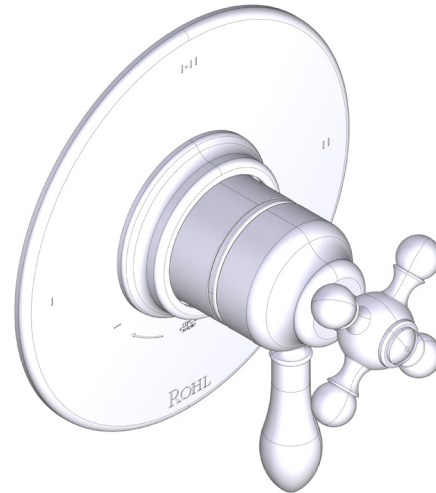

Arcana™ 1/2" Therm & Pressure Balance Trim with 3 Functions (Shared)

CORE MODEL: TAC23W1LM

UPC®

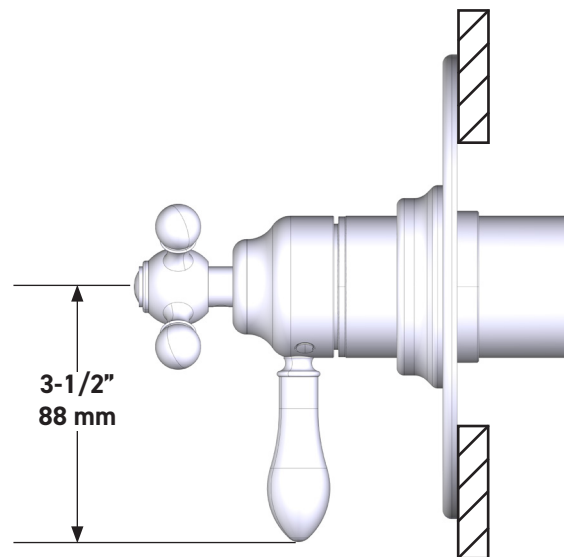
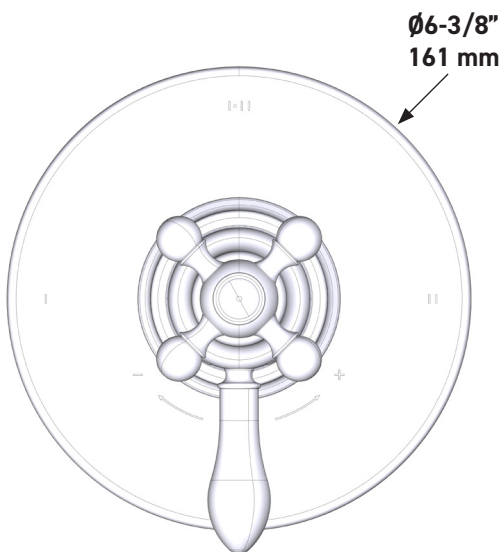

For warranty or additional information, contact:

US Customers

U.S.A.
houseofrohl.com/support
1-800-777-9762

Canadian Customers

QUEBEC / MARITIMES / WESTERN CANADA
QUÉBEC / MARITIMES / OUEST CANADIEN
QUEBEC / MARITIMOS / CANADA OCCIDENTAL
houseofrohl.ca/support
1-866-473-8442

ONTARIO
houseofrohl.ca/support
1-800-287-5354

SPÉCIFICATIONS

DESCRIPTION

- Combine à la fois les technologies thermostatique et d'équilibrage de la pression
- Contrôle de la température du type préréglage absolu
- Contrôle de la température et du débit avec inverseur
- 2 fonctions distinctes et 1 fonction partagée
- Soupape de plomberie brute vendue séparément :
 - Commander une soupape de plomberie brute thermostatique à équilibrage de pression no R23
 - Trousse de rallonge de la soupape n° R23 de 1 1/4 po disponible, commander la trousse n° EXT23KIT114
 - Trousse de rallonge de la soupape n° R23 de 3/4 po disponible, commander la trousse n° EXT23KIT34

CARTOUCHE

- 0-925 (Inclus)

GARANTIE

- La plupart des produits ou pièces comprend des «garanties limitées» contre les défauts de fabrication. Pour les clients des États-Unis : veuillez consulter houseofrohl.com/support; Pour les clients du Canada : veuillez consulter houseofrohl.ca/support pour connaître les conditions complètes de la garantie des produits et finis.

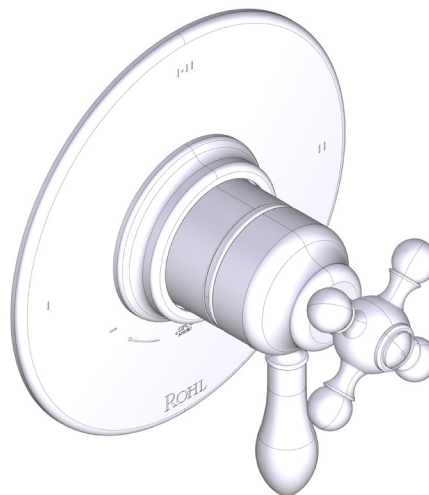

Garniture de soupape thermostatique à équilibrage de pression de 1/2 po, à 3 fonctions (partagées) Arcana^{MC}

MODÈLE DE BASE : TAC23W1LM

UPC®

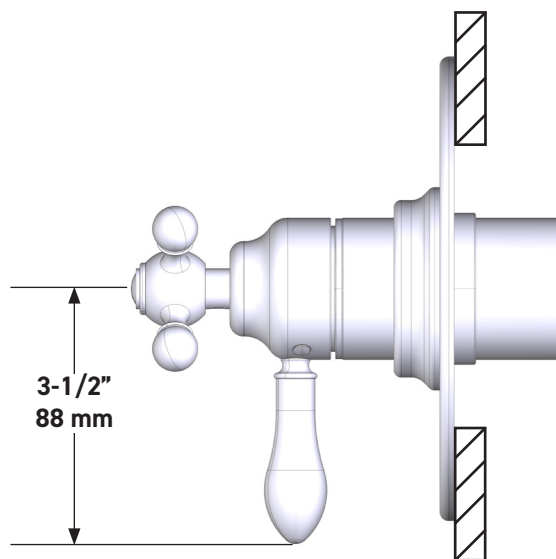
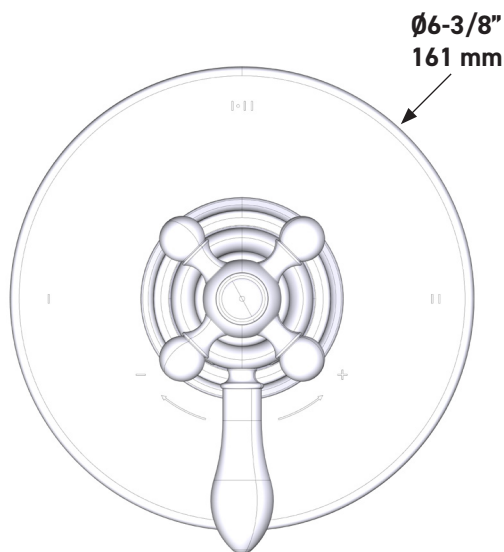

For warranty or additional information, contact:

US Customers

U.S.A.
houseofrohl.com/support
1-800-777-9762

Canadian Customers

QUEBEC / MARITIMES / WESTERN CANADA
QUÉBEC / MARITIMES / OUEST CANADIEN
QUEBEC / MARITIMOS / CANADA OCCIDENTAL
houseofrohl.ca/support
1-866-473-8442

ONTARIO
houseofrohl.ca/support
1-800-287-5354

ESPECIFICACIONES

DESCRIPCIÓN

- Combina tecnologías termostáticas y de equilibrio de presión
- Control de temperatura de configuración única
- Control de temperatura y volumen con desviador
- 2 funciones exclusivas y 1 función compartida
- La válvula empotrada se vende por separado:
 - Pida la válvula empotrada de equilibrio térmico y de presión R23
 - Kit de extensión R23 de 1-1/4" disponible, pida el kit EXT23KIT114
 - Kit de extensión R23 de 3/4" disponible, pida el kit EXT23KIT34

CARTUCHO

- 0-925 (Incluido)

GARANTÍA

- La mayoría de los productos o piezas cuentan con "Garantías Limitadas" por defectos de fabricación. A los clientes en EE. UU. se les recomienda visitar houseofrohl.com/support y a los clientes en Canadá, houseofrohl.ca/support, para consultar las condiciones completas de la garantía de los productos y acabados

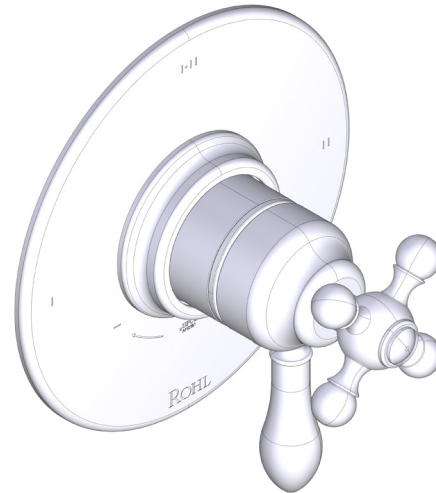

Moldura Arcana^{MR} de equilibrio térmico y de presión de 1/2" con 3 funciones (Compartida)

MODELO DE BASE: TAC23W1LM

UPC®

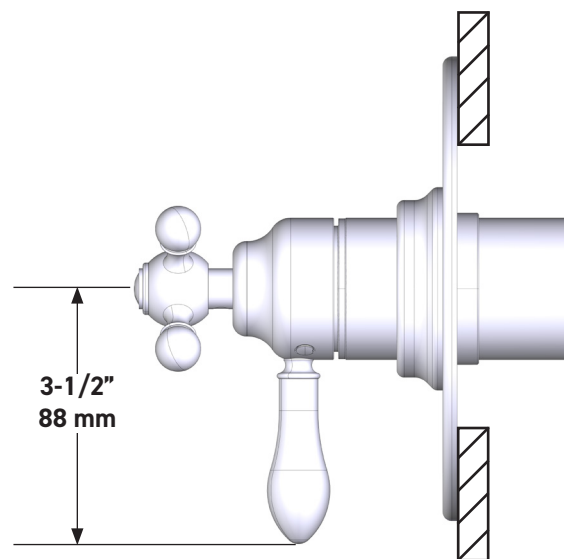
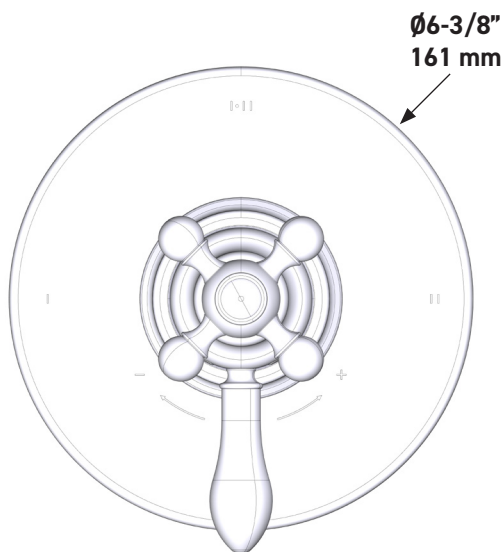

For warranty or additional information, contact:

US Customers

U.S.A.
houseofrohl.com/support
 1-800-777-9762

Canadian Customers

QUEBEC / MARITIMES / WESTERN CANADA
 QUÉBEC / MARITIMES / OUEST CANADIEN
 QUEBEC / MARITIMOS / CANADA OCCIDENTAL
houseofrohl.ca/support
 1-866-473-8442

ONTARIO
houseofrohl.ca/support
 1-800-287-5354