



WALK-IN BATHTUB SERIES

INSTALLATION AND OPERATION INSTRUCTIONS

Ristorre
14525 Monte Vista Avenue
Chino, CA 91710
1-844-883-2839
www.ristorre.com

Contents

Contents 2

Product Information 2

Important Safety Instructions 3

Inspection and Testing 4

Framing and Support 5

Subfloor 6

Electrical Connections 6

Prior to Installation 6

Installation Procedures 6030/5230/5433/3137 Models 6

Leveling Feet Adjustment 7

Optional Extension Kit Installation 5433 7

Back Panel Shelf Installation 5433 8

3-Wall Alcove Installation 6030 9

Final Steps 10

Installation Clean Up 10

Door Operation 10

Faucetry Installation 11

General Operation Information 11

Controls 12

Controlling Whirlpool Direction and Flow 12

Light Instructions 12

Operations 13

Aromatherapy Use 13

Removable Skirt Instructions 14

Adjustable Skirt Height Option 15

Heater 15

Cleaning 15

Ozone Sanitation System 15

Shower Information 16

Maintenance 16

Troubleshooting Procedures 16

WIT Reference Diagrams 17

Authorized Service 18

Warranty 19

Warranty Registration 22

Product Information

NOTE

Save these instructions for future use. Use the form below to record your model and serial number for future reference.

Date Purchased _____

Purchased From _____

Installed By _____

Serial Number _____

Model _____

Installer: Leave the manual for the homeowner.
Homeowner: Read this manual and keep for future reference.

Dealer/Installer
Information

Important Safety Instructions

This is a professional grade product. A working knowledge of construction techniques, plumbing and electrical installation according to codes are required for proper installation and user satisfaction. We recommend that a licensed contractor perform the installation of all Ristorre™ products. Our warranty does not cover improper installation related problems.

READ AND FOLLOW ALL INSTRUCTIONS. SAVE THESE INSTRUCTIONS.

Use this unit only for its intended use as described in this manual. Do not use attachments not recommended by the manufacturer. Never drop or insert any object into any opening.

DANGER

RISK OF ACCIDENTAL INJURY OR DROWNING! Do not permit children to use this unit unless they are closely supervised at all times. Do not use hydromassage bathtubs unless all suction guards are installed to prevent body and hair entrapment. Never operate the hydromassage bath if the suction cover is broken, damaged or missing. Do not operate this unit without the guard over the intake for the circulation pump (suction cover/strainer).

DANGER

RISK OF SEVERE INJURY FROM ELECTRIC SHOCK OR DEATH FROM ELECTROCUTION! Combos must be connected only to a supply circuit that is protected by two 20 amp ground fault circuit interrupter (GFCI). Whirlpools must be connected to a supply circuit that is protected by a 15 amp ground fault circuit interrupter (GFCI). Such a GFCI should be provided by the installer and should be tested on a routine basis. Follow the manufacturer's instructions when testing the GFCI. The GFCI should interrupt power. Push the reset button. Power should be restored. If the GFCI fails to operate in this manner, the GFCI is defective. If the GFCI interrupts power to the bathtub without the test button being pushed, a ground current is flowing indicating a possibility of an electric shock. Do not use this hydromassage bathtub. Disconnect the hydromassage bathtub and have the problem corrected by a qualified service representative before using.

DANGER

RISK OF ELECTRIC SHOCK! Do not permit electrical appliances (such as a hair dryer, lamp, telephone, radio or television) within 60" (1524mm) of this hydromassage bathtub. Connect only to a circuit protected by a ground fault circuit interrupter (GFCI). (For permanently connected units) A green colored terminal (or a wire connector) marked "G," "GR," "GROUND," or "GROUNDING") is provided within the terminal compartment. To reduce the risk of electric shock, connect the terminal or connector to the grounding terminal of your electric service or supply panel with a conductor equivalent in size to the circuit conductors supplying the equipment.

DANGER

PROLONGED IMMERSION IN HOT WATER MAY INDUCE HYPERTHERMIA! Hyperthermia occurs when the internal temperature of the body reaches a level several degrees above the normal body temperature of 98.6°F (37°C). The symptoms of hyperthermia include an increase in the internal temperature of the body, dizziness, lethargy, drowsiness and fainting. The effects of hyperthermia include:

- A. Failure to perceive heat.
- B. Failure to recognize the need to exit the bath.
- C. Unawareness of impending hazard.
- D. Fetal damage in pregnant women.
- E. Physical inability to exit the bath.
- F. Unconsciousness resulting in danger of drowning.







DANGER

This equipment is intended for indoor use only. Install the equipment in accordance with these instructions. Use supply wires that are suitable for 167°F (75°C), including the temperature rating of the supply conductors to be used. This unit should be electrically grounded and installed by a licensed contractor, electrician, and plumber. Building materials and wiring should be routed away from the motor/pump or blower or other heat producing components of this unit. A pressure wire connector is provided on the exterior of the motor/pump and heater to permit connection of an No. 8 AWG solid copper bonding conductor between this unit and all other electric equipment and exposed metal in the vicinity, as needed to comply with local requirements.

DANGER

Risk of fetal injury. Pregnant or possibly pregnant women should consult a physician before using a hydromassage bathtub equipped with a heater.

Important Safety Instructions (Continued)

-  **CAUTION** Keep body and hair a minimum of 6" (152mm) away from the suction fitting at all times when the hydromassage system is in operation. Hair longer than shoulder length should be secured close to the head.
-  **CAUTION** Do not immerse the controls by overfilling the bath.
-  **CAUTION** To avoid injury, use care when entering and exiting the hydromassage bathtub.
-  **CAUTION** Do not use drugs or alcohol before or during the use of a hydromassage bathtub equipped with a heater. Possible drowning may occur.
-  **CAUTION** Do not use a hydromassage bathtub equipped with a heater immediately following strenuous exercise.
-  **CAUTION** Use this unit only for its intended use as described in this manual. Do not use attachments not recommended by the manufacturers. Do not tamper with user-operated controls or such devices.
-  **CAUTION** Water temperature in excess of 104°F (40°C) may be injurious to your health. Check and adjust water temperature before use.

SAVE THESE INSTRUCTIONS.

The Company has obtained applicable code (standards) listings generally available on a national basis for products of this type. It is the responsibility of the installer/owner to determine specific local code compliance prior to installation of the product. Proper installation of the units is the responsibility of the installer. Ristorre is not responsible for water damage due to improper installation. Product specifications are subject to change without notice.

Inspection and Testing**Visual Inspection**

- 1 Remove the bathtub from the shipping carton. Be careful not to scratch the surface of the bathtub on exposed staples. Remove the staples or fold them into the carton. Retain the carton until satisfactory inspection of the product has been made. Do not lift the bathtub by the plumbing at any time; handle by the frame only.
- 2 Inspect the shell and bathtub components. Should inspection reveal any damage or defect in the finish or visible damage to any components, do not install the bathtub. Damage or defect to the finish claimed after the bathtub is installed is excluded from the warranty. Ristorre's responsibility for shipping damage ceases upon delivery of the products in good order to the carrier.
- 3 Refer any claims for damage to the carrier. For explanation of warranty coverage and limitations, refer to the published warranty information packed with the product or in the back of this manual.

Bathtub Water and Operational Test

All bathtub units are factory tested for proper operation and watertight connections prior to shipping. However, the unit must be retested by the installer prior to installation. Ristorre is not responsible for any defect that could have been discovered, repaired, or avoided by following this inspection and testing procedure:

- 1 Place the bathtub on a level surface, near appropriate electrical supply, water supply, and water drainage. A driveway is a suitable choice.
- 2 Cover the drain and overflow hole with tape or a stopper and fill the bathtub to the bottom of the overflow hole.
- 3 Allow bathtub to stand for 5 minutes.
- 4 Plug in motor/pump and turn unit on. Confirm that all features function as described in the Operation section of this manual. Do not install the bathtub if bathtub fails to operate as described.
- 5 Visually inspect all joints for leaks. Do not install the bathtub if leaks are detected.
- 6 Return bathtub to box or otherwise protect from damage until time of installation.

Framing and Support

READ ALL INSTALLATION INSTRUCTIONS COMPLETELY. IMPROPER INSTALLATION WILL VOID THE WARRANTY.

IMPORTANT

Make sure that walls and floor meet fire safety requirements of local building code and/or FHA/HUD Minimum Property Standards.

Observe all governing codes and ordinances.

- 1 Proper installation is your responsibility. Have a qualified technician install this bath.
- 2 Installation using a ground-fault circuit-interrupter (GFCI) is required.
- 3 It is the installer's responsibility:
 - To contact a qualified electrical installer.
 - To assure that electrical installation is adequate and in conformance with National Electrical Code (NEC).
 - To assure that plumbing installation is adequate and in conformance with the Uniform Plumbing Code (UPC).

A Technical Specification has been included with your bathtub. The Technical Specification will contain pertinent information regarding your Ristorre™ product. Locate the Technical Specification at this time.

NOTES

Finished alcove must have correct interior dimensions, as shown in the rough-in diagrams in the Technical Specification, to properly install unit. For three wall alcove installations, use an integral molded three-sided tiling flanged bathtub. Ristorre does not recommend utilizing bathtubs without an integral tiling flange in an alcove installation where a shower head would be installed above the unit and utilized as a shower.

- In remodeling, if necessary, add studs at each end to provide a vertical nailing surface for the side nailing flange of bath fixture product.
- To avoid obstructions during installation make sure that supply lines, spout pipe and valve plumbing do not project into alcove.
- Bathtub requires a 4" x 14" (102mm x 356mm) recommended floor opening for the 1 1/2" (38mm) drain, waste and overflow (DWO) kit.
- Be sure floor opening location matches bathtub fixture drain location.
- The unit must be supported from the bottom of the bathtub and not solely from the bathtub rim.
- Per UPC code, access must be provided to the pump/motor for your specific model (Figure 1). It is the responsibility of the installer, building contractor, or owner to provide access for service. Ristorre is not responsible for any costs related to obtaining access for repair. The owner shall bear such costs and, if appropriate, must seek recovery from the installer. Primary and secondary service access locations are shown in the rough-in diagrams contained in the Technical Specification.
- Provide adequate ventilation for cooling and supply sufficient air for the pump/motor. Do not insulate around the equipment.

Fig. 1

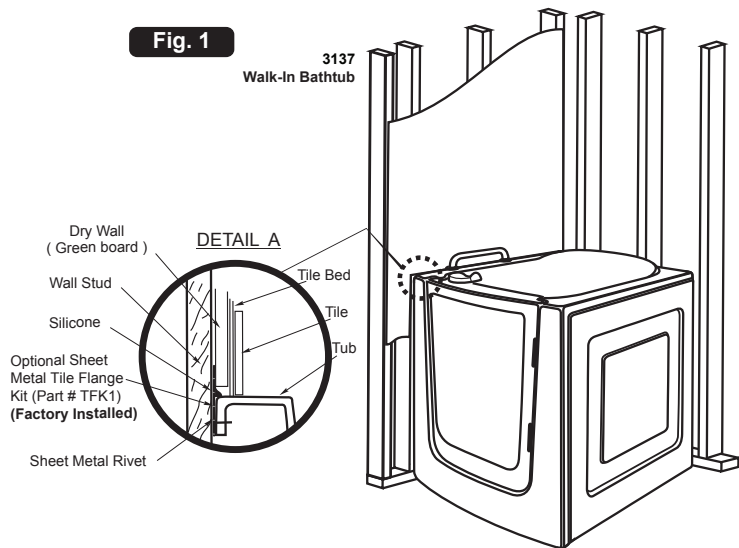

5433 Walk-In Bathtub (with optional filler extension kit)

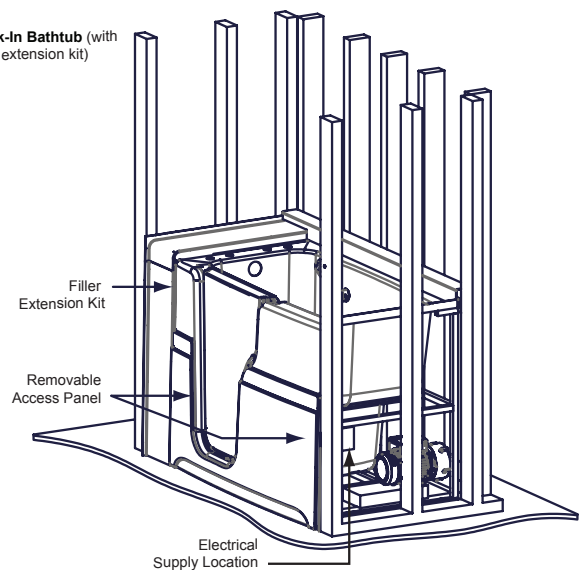

5230/6030 Walk-In Bathtub

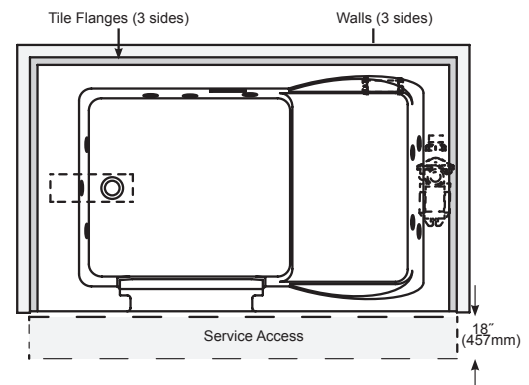

Subfloor

- 1 Prepare the subfloor for the drain and ensure that the area is level. The drain/overflow of the bathtub extends below the bottom of the bathtub. Identify the drawing in the Technical Specification that corresponds with your bathtub.
- 2 The bathtub must remain level in order for it to drain properly and must make contact with the leveling feet.
- 3 Floor must support seventy five pounds (75 lbs) per square foot load.

Electrical Connections

⚠ DANGER

Risk of electric shock. Connect only to a circuit protected by a GFCI.

⚠ CAUTION

- Electrical outlet must be mounted 4" (101mm) above the floor line and 12" max (305mm) inside from the edge of the bathtub, or in accordance with local building and electrical codes.
- Risk of component overheat. Do not use electric extension cord to power this unit. Operating the pump without enough water in the bathtub can cause permanent damage to the pump/motor.
- If the GFCI unit indicates a malfunction, per manufacturer's instructions, turn OFF power and do not attempt to use the bathtub until the source of the problem has been identified and corrected.

Fig. 2

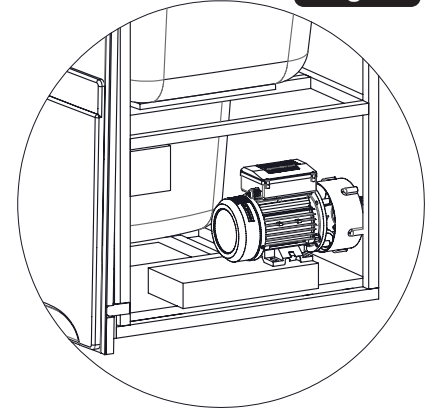

NOTES

When using electrical products, basic precautions should always be followed:

- Always follow local building and electrical codes. Grounding is required. The unit should be installed and grounded by a qualified electrician.
- Combination Models: Two separate dedicated 120VAC GFCI protected circuits are required to supply the pre-installed plug box.
- Whirlpool Models: A dedicated 120VAC GFCI protected is required for pump/motor. A separate 120VAC GFCI protected circuit is required for the heater.

Prior to Installation

NOTE

Before you begin your installation, please read the following:

- Proper installation of the spout plumbing and compliance with local codes are the responsibility of the installer. Ristorre does not warrant connections of water supply fittings and piping, fill systems, or drain/overflow systems. Nor is it responsible for damage to the bathtub which may occur during installation.
- Provide adequate ventilation around the equipment to ensure sufficient air flow and cooling. Do not block blower intake for any reason. Do not insulate the blower for any reason. Keep blower clear of all debris.
- It may be necessary to level the Walk-In Bathtubs. Use the leveling feet to adjust the levelness of the bathtub. The leveling feet operate in a similar manner as those for an appliance.
- It is important to check the level prior to water testing. The unit must be level for water testing, as this helps with the door seal alignment. The adjustment nut allows you to adjust the height of the base. The locking nut allows you to lock in the desired height by tightening the nut. Under no circumstances will it be necessary to remove the leveling feet.
- 50 Gallon water heater recommended. Consult with your installer/plumber for your household's specific requirements.

Installation Procedures 5433/3137 Models

- 1 Make sure framed-in alcove is of proper size per Ristorre dimensions, square, and plumb; check floor for levelness (Figure 3). Rough-in should be kept to a minimum until the unit is on the job site. Measurements may vary +0 or -3/8" from original specifications.
- 2 Sufficient clearance must be provided for access to service connections (pump/motor, controls, heater plumbing and electrical hook ups).

Height "H" Dimensions

- 5433: 37.5"
- 3137: 36.5"

Fig. 3

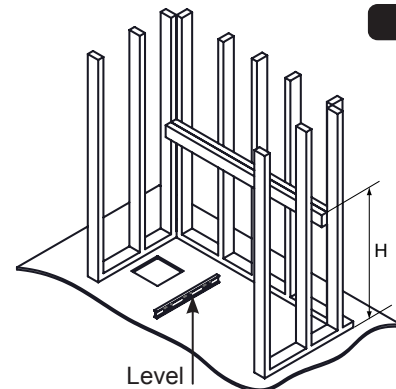

Installation Procedures 5433/3137 Models (Continued)

NOTES

Place the tub in the alcove with the front skirt firmly on the floor. The bathtub must be set level. To check, use a level on top of the ledges on both ends of tub and on top of dam (Figure 4).

All adjustable feet must come in contact with the floor.

All plumbing hardware (drain/waste overflow, water supply) must be installed prior to setting the bathtub in place.

Fig. 4

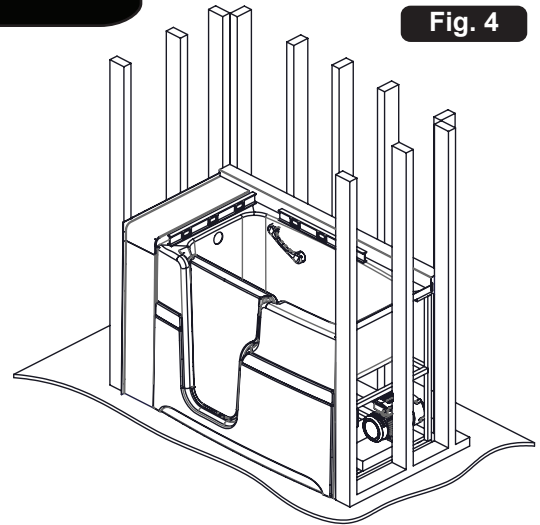

IMPORTANT

Tile flange unit is required in a 3-wall alcove installation setting.

Leveling Feet Adjustment

NOTES

The 3137/5433 comes factory pre-leveled; however, it may be necessary to make adjustments to the leveling feet. The leveling feet operate in a similar manner as those for an appliance.

It is important to check the level prior to water testing.

- 1 The adjustment nut allows you to adjust the height of the base. The locking nut allows you to lock in the desired height by tightening the nut.
- 2 If it is necessary to level the bathtub, start by leveling the (1) center back wall leg, then move to the (4) corner legs, then finish at the front center leg.
- 3 Check the bathtub for levelness. If the bathtub is level, tighten the locking nut (Figure 5).
- 4 If the bathtub is not level, repeat the above steps.
- 5 **For optional reverse plumbing installations 5433 only:** Raise leveling feet to 3" as shown (Z) and install per local uniform plumbing code (UPC) requirements.

Fig. 5

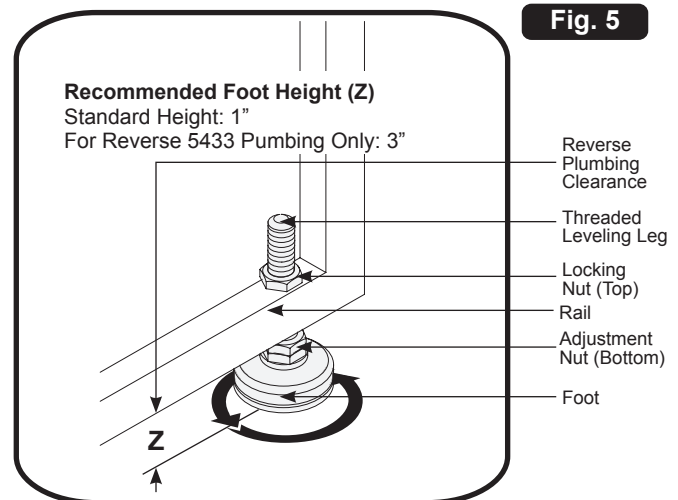

- Rotate the leveling foot clockwise to lower the unit.
- Rotate the leveling foot counter-clockwise to raise the unit.

Optional Extension Kit Installation 5433

NOTES

Pre-drilling flange is recommended to avoid cracking of the acrylic unit. The front extension panel must be installed prior to installing the top extension panel. The illustration (Figure 6) is shown from the inside of the unit for clarity purposes. All work shown may be accessed from the top of the unit or through the access panel cutouts.

Fig. 6

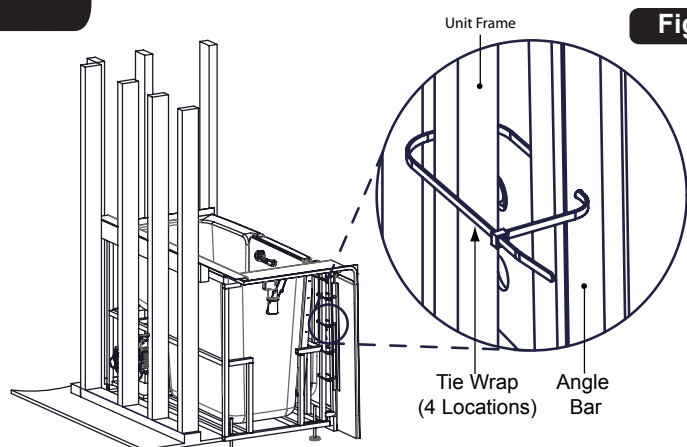

Optional Extension Kit Installation 5433 (Continued)

English

Front Panel Installation -

- 1 Use cable ties to attach the front extension panel to the frame of the unit.
- 2 Route the cable tie around the frame and through the pre-drilled angle bar (Figure 6 page 7). Repeat in four (4) locations.
- 3 Insert the tip of the cable tie into the receiving end of the cable tie.
- 4 Once the tip has been inserted, pull the cable tie tight until the front extension panel is resting completely against the unit (Figure 6 page 7).
- 5 Complete the fastening through vertical side flange approximately 8" (205mm) on center (Figure 8).

Fig. 7

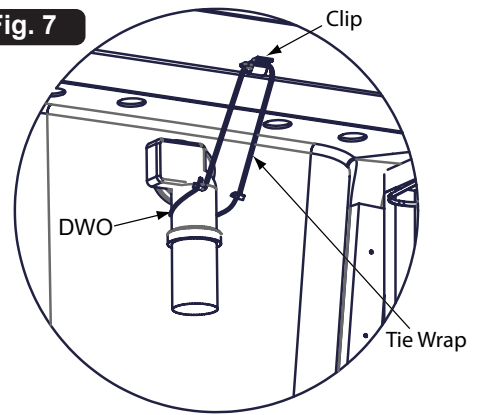

Fig. 8

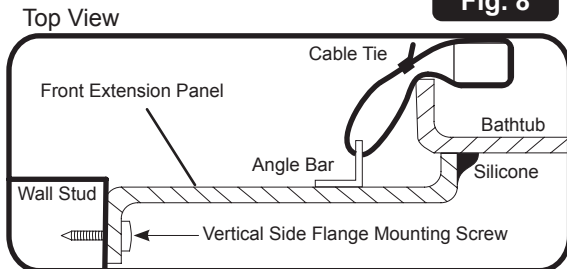
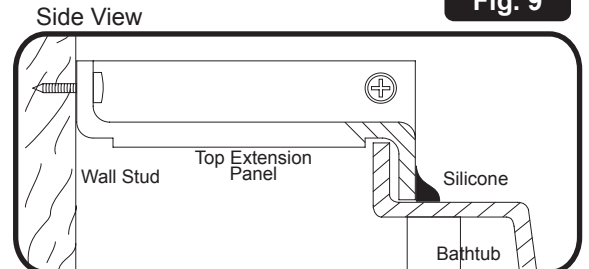

Fig. 9



Top Panel Installation -

- 1 Route the cable tie around drain waste overflow (DWO) and through the plastic clip as illustrated (Figure 7).
- 2 Place the top extension panel over the opening and fasten through the topside flange at each stud 16" (405mm) on center, working from both ends toward back center (Figure 9).
- 3 Once complete, apply a continuous bead of silicone sealant around the entire seam between the top and front extension panels and the bathtub rim. Allow sealant to cure according to manufacturer's instructions.

Back Panel Shelf Installation 5433

- 1 Fasten Angle to Studs as illustrated (Figure 10). Fasten at every stud.
- 2 Place Acrylic back shelf over Ledge as illustrated (Figure 10).
- 3 Apply a bead of Silicone to all seams.

Fig. 10

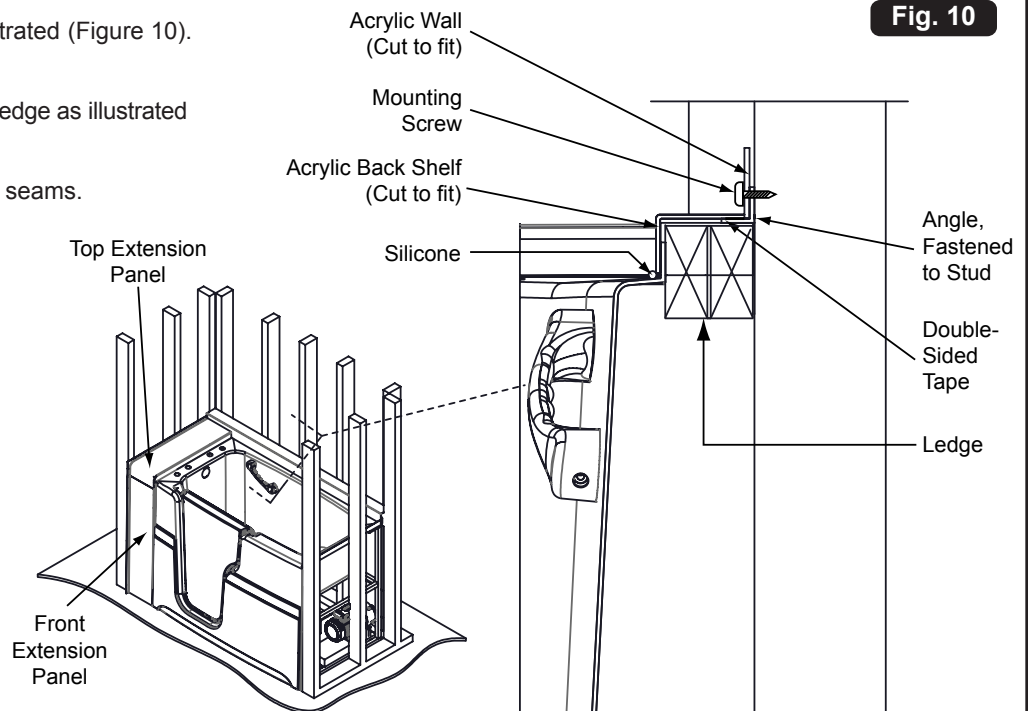

3-Wall Alcove Installation 6030

- 1 Install the drain/overflow according to the manufacturer's instructions. Refer also to the Technical Specification Manual.



Watertight installation of the drain is the installer's responsibility. Drain leakage is excluded from the Ristorre warranty of this product.

- 2 Install the faucet at this time. It is recommended that the faucet be installed by a qualified plumber.
- 3 Install the flange (purchased separately) according to the instructions that are included with the kit. If the bathtub is equipped with an integrated flange skip this step.
- 4 Turn off the power supply to the GFCI protected circuit.
- 5 Insulation may be placed within the bathtub surround, except around the motor/pump.
- 6 Connect flex water supply lines to faucet and plug power cords into GFCI outlet.
- 7 Place the bathtub into the niche. Screw the flange to the wood stud (Figure 11A). It may be necessary to shim the unit to close up any gaps between the wood stud and the flange.
- 8 Align the bathtub and connect the drain.
- 9 Inspect all fittings, plumbing, and control lines after inserting the bathtub to insure the components are not damaged, disconnected, or contacting the finish surface substrate or support members (Figure 11B).
- 10 Turn on the power supply to the dedicated GFCI protected circuits and check system operation.
- 11 Complete all finish work around the perimeter of bathtub to seal the space between the rim and the finished deck.
- 12 Turn on the power supply to the dedicated GFCI protected circuits and check system operation.



The tub comes factory pre-leveled; however, it may be necessary to make adjustments to the leveling feet. The leveling feet operate in a similar manner as those for a washer/dryer (Figure 11C).



It is important to check the level prior to water testing. The unit must be level for water testing, as this helps with the door seal alignment.

- 13 If it is necessary to level the bathtub, start by leveling the outside four (4) legs, and then move to the two (2) legs on the door. The unit is pre-leveled prior to shipment and should not be tampered with, if not required.



The adjustment nut allows you to adjust the height of the base. The locking nut allows you to lock in the desired height by tightening the nut.



Under no circumstances will it be necessary to remove the leveling feet.

Fig. 11A

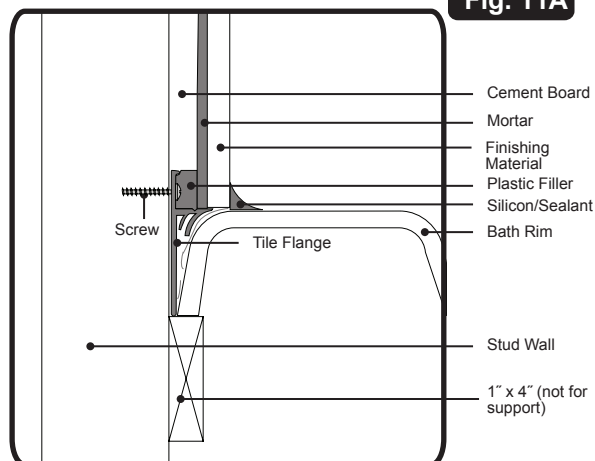

Fig. 11B

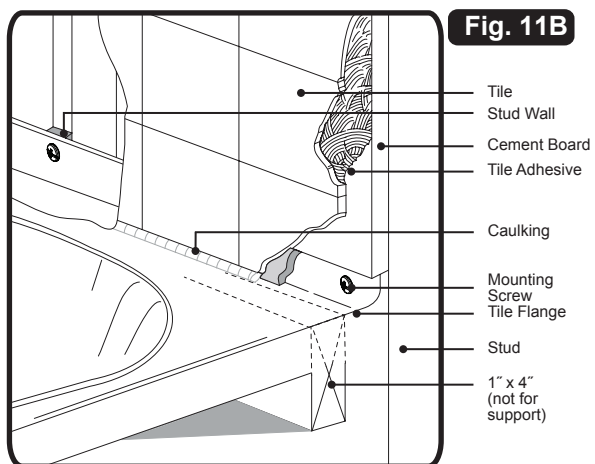
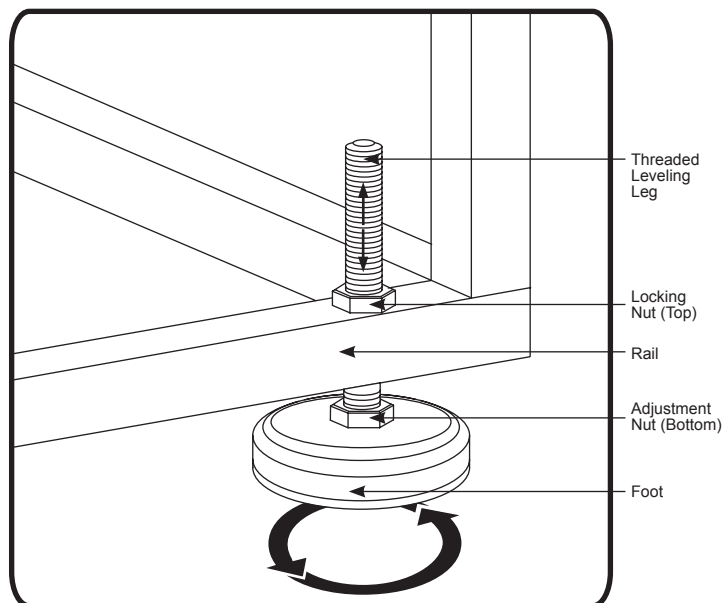

Fig. 11C



Final Steps

- 1 Finishing of other trades should be done in conformance with applicable codes and generally accepted building practices.
- 2 Inspect all fittings, plumbing, and control lines after inserting to insure the components are not damaged, disconnected, or contacting the finish surface substrate or support members. *Note: Tubs are factory pre-drilled for deck mounted tub fittings.* Connect flex water supply lines to faucet, connect bathtub drains and plug power cords into GFCI outlets.
- 3 Turn on the power supply to the dedicated GFCI protected circuits and check system operation.
- 4 Water test all fixtures, run pump, and test operation. Apply a continuous bead of silicone sealant around the entire seam between the counter and the bathtub rim (Figure 12). *Note: Silicone bead represented by dashed lines.* Allow sealant to cure according to manufacturer's instructions.
- 5 Finally, apply a bead of silicone along the left, right and top seams of the removable front skirt panel. Wipe off all excess silicone and allow it to cure according to manufacturer's instructions.

Fig. 12

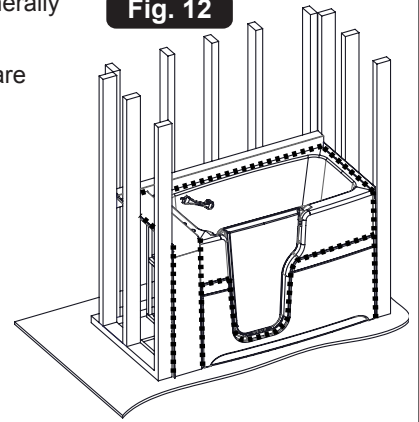

Installation Clean Up

To avoid dulling and scratching the surface of the bathtub, never use abrasive cleaners. For most soiled surfaces, a mild liquid detergent and warm water is sufficient. The following is also recommended:

- Remove spilled plaster with a wood or plastic edge. Spots left by plaster or grout can be removed if lightly rubbed with detergent on a damp cloth or sponge. Do not use metal scrapers, wire brushes or other metal tools, as they will damage the bathtub's surface.
- Paint, tar, or other difficult stains can be removed with Fantastik® or soapy water.
- Minor scratches which do not penetrate the color finish can be removed by lightly sanding with 600-grit wet/dry sandpaper. You can restore the glossy finish to the acrylic surface of the bathtub with a special compound, Meguiar's #10 Mirror Glaze. If that is not available, use automotive rubbing compound followed by an application of automotive paste wax.
- Major scratches and gouges which penetrate the acrylic surface will require refinishing. Call Ristorre to find a service agent in your area for repairs (1-844-883-2839).

Door Operation

NOTE

- 1 The door opens to the inside of the bathtub. Use the inside door handle to engage the locking mechanism (Figure 13).
- 2 Seal will prevent leakage. Provide a visual check and clean any debris from the seal area before filling the bathtub with water (see illustrations).
- 3 The door opens to the outside of the bathtub. Use the handle on top of the door to engage locking mechanism (3137 only).
- 4 Do not open door until all water has been drained from the bathtub.
- 5 Be sure tub door remains in the open position when not in use. Failure to do so could deform door gasket causing the tub door to leak.

Fig. 13

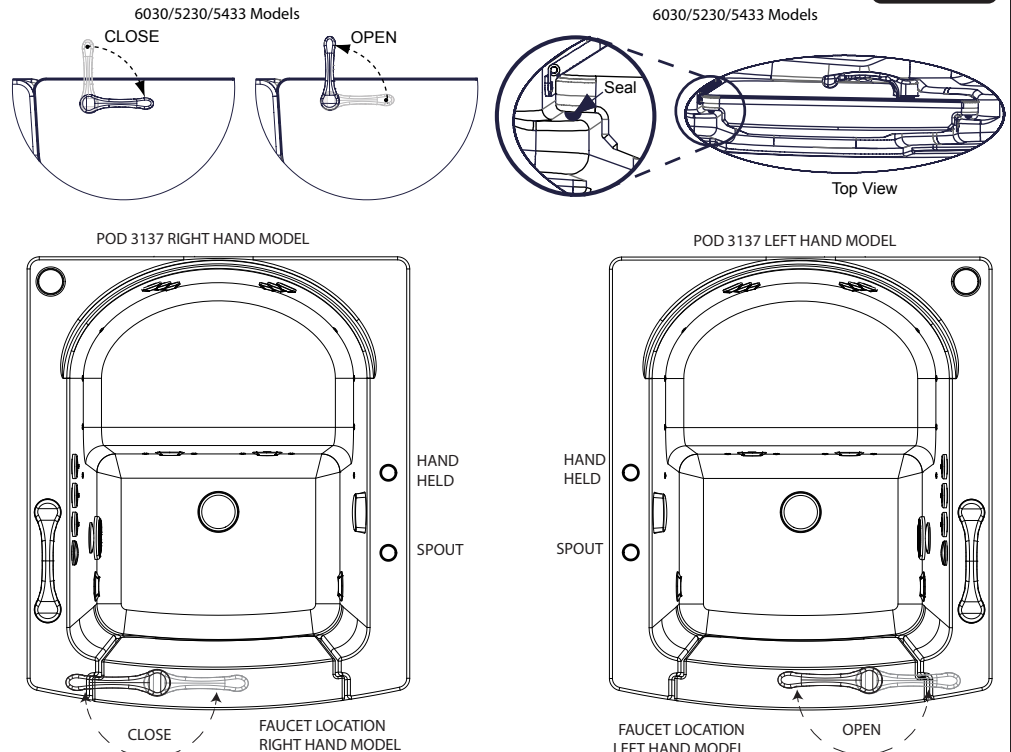

Faucetry Installation

Install the faucetry and drain/waste overflow trim (DWO) at this time (please see installation instructions that came packaged with these items).

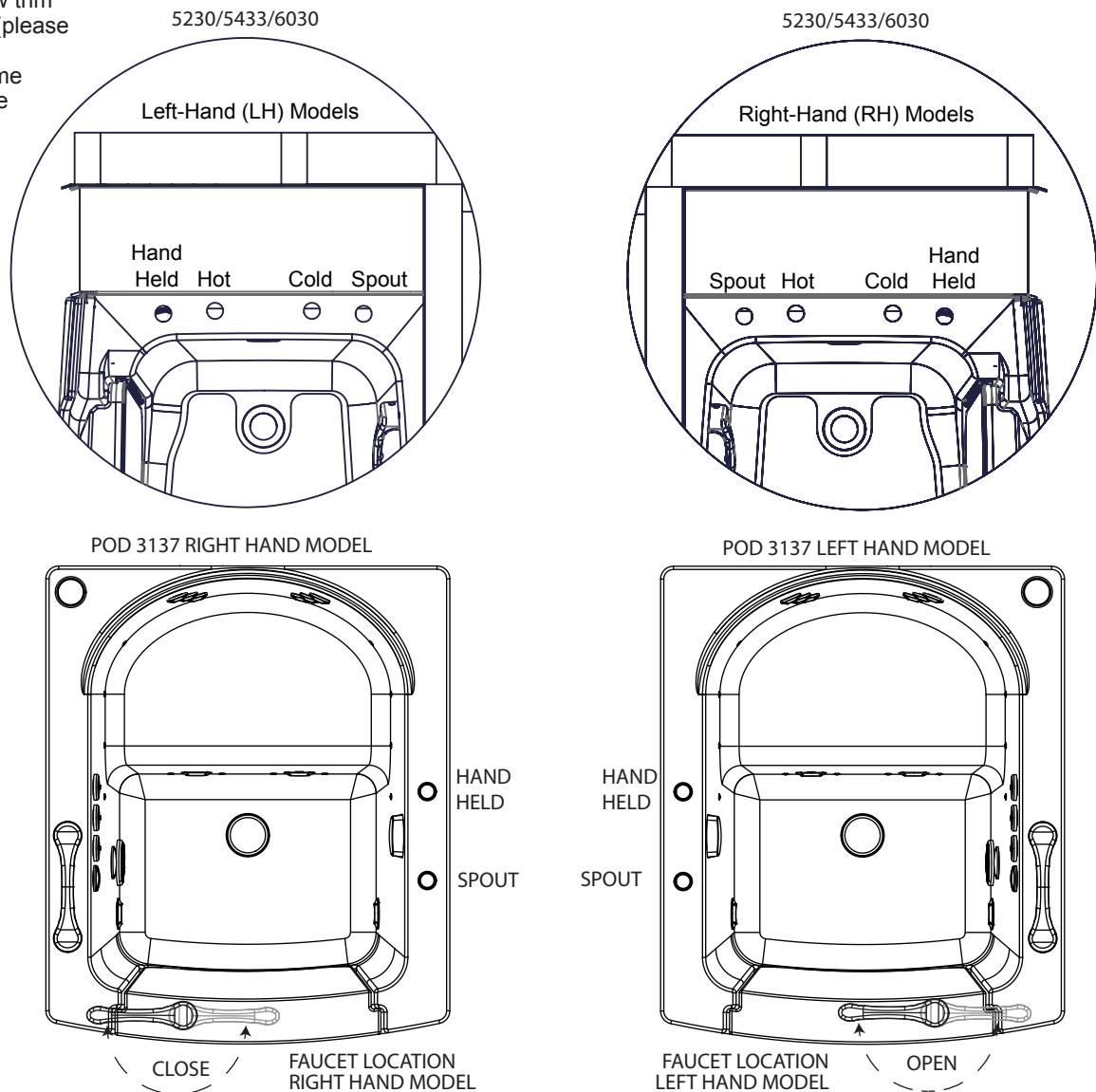
Fig. 14

General Operation Information

All Ristorre™ bathtubs manufactured are designed for "fill and drain," which means the bathtub should be drained after each use and filled with fresh water by the next bather. This is a health precaution, as these bathtubs are not designed to hold water continuously like pools or spas.

Close the drain and fill the bathtub until water is at least 1" to 2" (25mm to 51mm) above the highest jet (see water line indicated in the illustration - Figure 15). Do not turn on the whirlpool system at any time if the jets are not completely immersed in water. Running the whirlpool system when there is insufficient water in the bathtub could result in water spraying outside the bath area and will damage the recirculating pump.

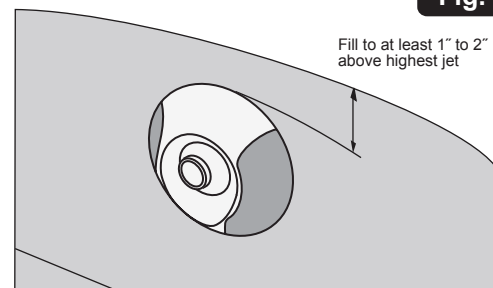
Fig. 15

Controls

NOTE

For Combination models, Whirlpool On/Off, Pure Air, Light and Air Control control operations are applicable. For Whirlpool models, only Whirlpool On/Off Air Control operations are applicable.

Fig. 16

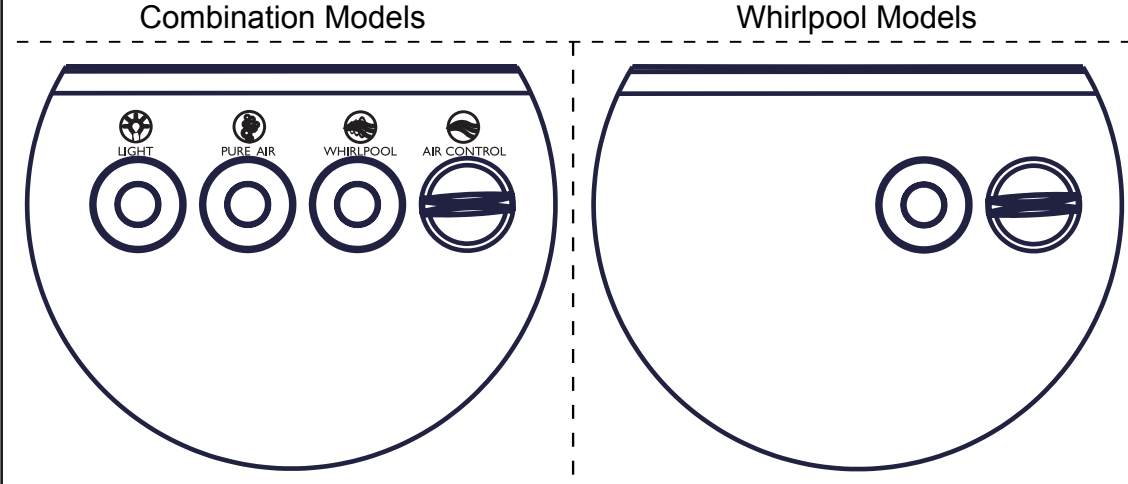

Controlling Whirlpool Direction and Flow

Direction (Figure 17A)

To change the direction of the water flow, swivel the jet nozzle to the desired angle.

Water Force (Figure 17B)

Increase the force of the flow by rotating the jet face to the left (counterclockwise). Decrease the force of the flow by rotating the jet face to the right (clockwise). *Note: Jet face spins 360°. Turn 180° clockwise to close and 180° counterclockwise to open.*

CAUTION

Never run the whirlpool system with all the jets closed.

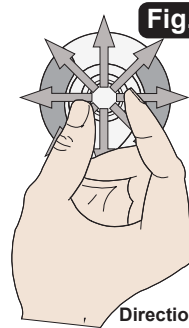

Fig. 17A

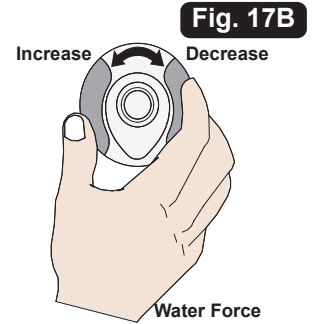
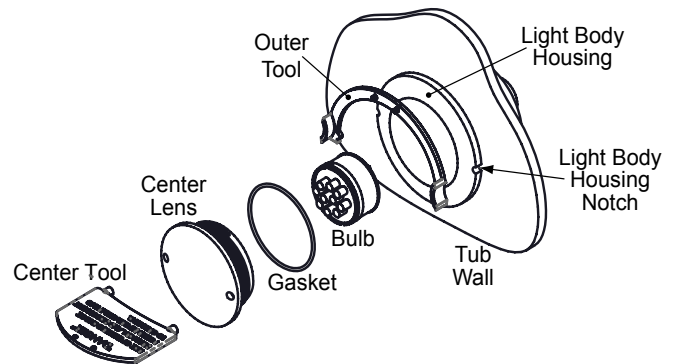

Fig. 17B

Light Instructions

To change a bulb after installation, follow the instructions engraved on the Hydro Tool (Center Tool). The outer tool holds the light body from turning (Figure 18). Insert the two tabs into the two notches on the outside diameter of the light body while using the inner tool to turn the front lens of the light assembly (counter-clockwise to remove, clockwise to install).

Fig. 18



Operations

Combination Operation:

Pump/Motor Operation:

To turn the Pump/Motor ON, press the Pump/Motor button once. To turn the Pump/Motor OFF, press the Pump/Motor button again (Figure 21).

Blower Operation:

To turn the Blower ON, press the Blower button once. To turn the Blower OFF, press the Blower button again (Figure 20).

Light Operation:

To turn the light ON, press the Light button once. To turn the light OFF, press the Light button again (Figure 19). Light will cycle a different color every time you press the Light ON. See below for sequence.

Light Color Sequence: 1. Ocean Blue, 2. Majestic Gold, 3. Shamrock Green, 4. Fiery Red, 5. Chameleon Mode, 6. Party Mode, 7. Bright White, 8. Aqua Blue, and 9. Soothing Violet.

Whirlpool Operation: In the closed position (Figure 22), the jets massage with only water. In the open position, air mixes with water to create a deep, wide plume of massaging bubbles.

NOTE

After use, drain and press the Blower button once to turn the Blower ON, then quickly press the Blower button again to turn OFF. This will purge the lines.

Fig. 19

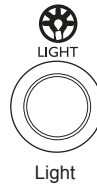

Fig. 20



Fig. 21



Fig. 22

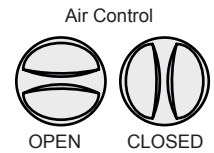

Whirlpool Operation:

ON: Press the Pump/Motor button once to turn the whirlpool jets ON.

OFF: Press the Pump/Motor button a second time to turn the whirlpool jets OFF (Figure 23).

Whirlpool Control (Figure 24)

In the closed position, the jets massage with only water.

In the open position, air mixes with water to create a deep, wide plume of massaging bubbles.

Fig. 23



Fig. 24

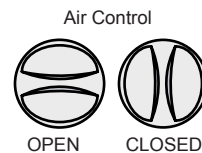

Aromatherapy Use

To use the aromatherapy feature:

Fig. 25

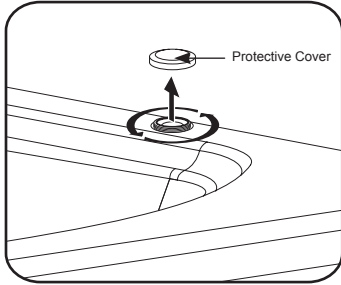

Remove the protective cover from the housing receptacle (located on the deck of the bathtub). An aromatherapy cartridge comes pre-installed in the unit.

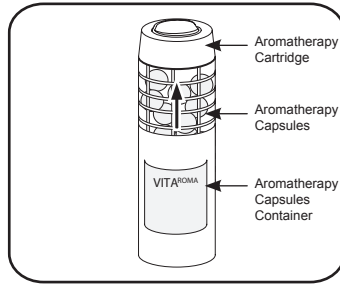

Remove the aromatherapy cartridge from the aromatherapy capsules container.

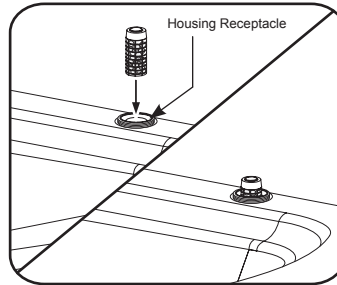

Place the aromatherapy cartridge into the housing receptacle until the aromatherapy cartridge is completely inside the housing.

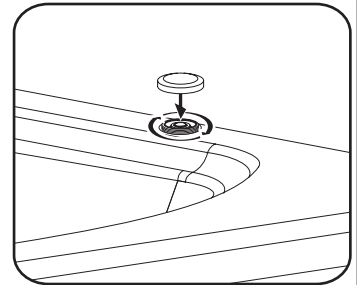

Reattach the protective cover. The aromatherapy feature is now ready to use.

CAUTION

Do not remove cap while blower is operating.

Removable Skirt Instructions

To remove the front skirt panel, you must release it by carefully cutting through the silicone bead at the left, right and top seams. Then grasp an edge and pull to separate (Figure 26A). Prior to reinstallation, you must clean and remove any old silicone from the removable panel and underlying surface.

Skirt Panel Adjustment (Figure 26B):

To reinstall skirt panel, align the six (6) posts on the panel with the six (6) receptor sockets on the tub and press into place. Insert a flat head screwdriver into each receptor socket. Turn clockwise to tighten and counter-clockwise to loosen. Apply a new bead of silicone at the left, right and top seams to complete panel installation.

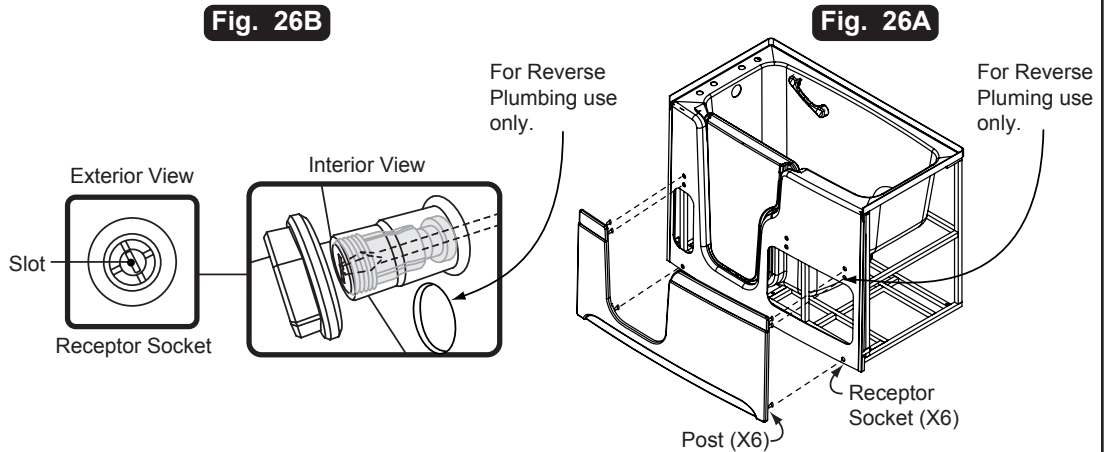

Skirt Panel Removal for Ristorre™ 6030 Models Only (Figure 26C):

To remove the front access panels, grasp an edge and pull toward you to separate. The access panels are magnetically secured.

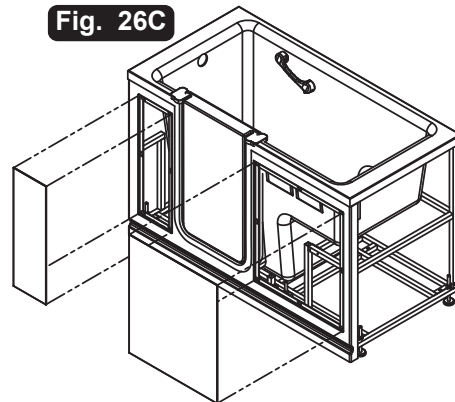

Ristorre™ 6030 ONLY

Optional Adjustable Skirt Height Adjustment

For optional reverse plumbing installations only: Remove the top three skirt receptors (Figure 26B) and reinstall them 2" lower into the factory drilled holes.

Adjustable Skirt Height Option 5433

These instructions are intended for use when the factory-standard height of the unit must be raised. This is to allow for proper drainage of rough-in plumbing located away from the unit.

- 1 Remove the skirt access panel and set aside to gain access to the leveling feet. Your unit is factory preset to a height of 37.0 inches. You must raise all leveling feet by 2.0 inches by performing step 6 in the Leveling Feet Adjustment section (Page 7).
- 3 Next, you will need to relocate the top three skirt receptors by removing their nut on the back side. Move each receptor down 2" to the factory-drilled holes, then reinstall each until snug. See Removable Skirt Instructions (Page 14).
- 4 Reattach the skirt. Notice that you will only be using the top three holes to mount it. The lower posts are now located below the unit (this is acceptable). Refer to Removable Skirt Instructions (Page 14) for further adjustments to the panel.
- 5 Silicone the perimeter of the removable skirt to finish installation.
- 6 For reverse plumbing, install per local Uniform Plumbing Code (UPC) requirements.

Heater

The heater turns ON automatically anytime whirlpool operation is active. Heater operation is not displayed on the control panel. There is a visible indicator light on the heater itself that signifies the heater is operating. The heater will help maintain the temperature of the water in the bathtub (Figure 27).

Vacuum Switch

The heater is equipped with a preset vacuum switch which will not allow the heater to turn ON if the pump is not running and water is not flowing through the whirlpool system.

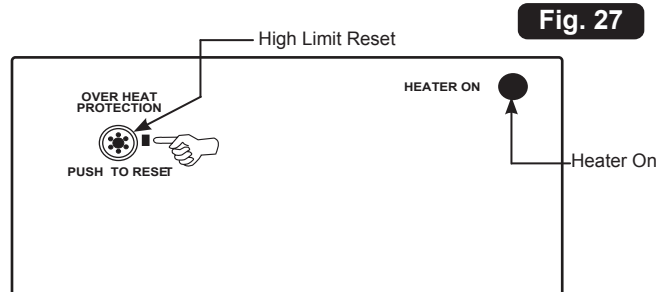

High-Limit Switch

The heater includes an exclusive High-Limit switch. This safety circuit will not false trip from hot tap water. It will only turn OFF the heater if the thermostat fails. To reset, press the button. If the high-limit trips frequently, please contact us at www.ristorre.com, or at 1-844-883-2839.

Cleaning



Do not use oil or oil-based bathtub additives. Never use abrasive or caustic household cleaners on any Ristorre™ bathtub.

If you want to use any kind of bathtub additive, use only a small amount of low-foaming powder; the whirlpool action intensifies the foaming properties of soaps.

The use of certain bathtub oils, bubble baths, and bathtub additives may increase the level of accumulations of bathtub residue in the whirlpool system and may cause false reading of the water level sensors (applicable only for units equipped with water level sensor). If excess accumulations persist, you should discontinue use of these products.

To remove accumulations of bathtub residue from the whirlpool system, it is recommended that a bathtub be cleaned regularly. For best results, however, we recommend that you clean your bathtub after each use using Systems Clean™, an exclusive two-part plumbing system cleaner made specifically for whirlpool bathtubs. Systems Clean™ is available through an authorized Ristorre Distributor, by calling us direct at 1-844-883-2839 or online at www.ristorre.com.

Ozone Sanitation System

Some units have a sanitation system installed. Electrical connections and power supply for the ozone sanitation system are incorporated into the control design of the unit. No additional connections are required for the ozone sanitation system. *Note: This system only operates while the whirlpool pump is running.*

Shower Information

Because of the Ristorre™ Walk-In Bathtub's unique design, a rigid shower door cannot readily be installed. If a shower is desired, we recommend using the hand-held shower supplied with the unit in conjunction with a shower curtain, as this will allow the user to control the direction of the spray.

NOTE

Proper installation of a shower is the responsibility of the installer. Ristorre is not responsible for damage to the unit or for water damage which might occur due to its installation.

Maintenance

To clean your bathtub, simply use a mild, nonabrasive liquid detergent solution as mentioned in the cleaning section above. You can protect and restore the gloss to a dulled acrylic surface by applying Meguiar's #10 Mirror Glaze, a product specifically designed for use on acrylic finishes. If Meguiar's is not available, use a fine grade automotive rubbing compound followed by an application of clear automotive paste wax.

Minor scratches which do not penetrate the color finish can be removed by lightly sanding with 600-grit wet/dry sandpaper. Restore the gloss using Meguiar's Mirror Glaze or automotive paste wax. Major scratches and gouges which penetrate the acrylic surface will require refinishing. Call Ristorre to find a service agent in your area for repair (1-844-883-2839).

Suction Cover/Strainer Maintenance

Clean the suction cover/strainer of hair and debris when necessary (Figure 28).

- ① Remove the center screw and detach the suction cover.
- ② Clean the cover by back flushing debris from the holes.
- ③ Reinstall the suction cover immediately after cleaning.

WARNING

Keep hair a minimum of 6 inches (152 mm) away from the suction fitting at all times when the whirlpool system is operating. Hair longer than shoulder length should be secured close to the head, or a bathing cap should be worn.

WARNING

Do not operate the whirlpool system with the suction cover/strainer removed! It is a safety device and must always be in place on the suction fitting to minimize the potential hazard of hair and body entrapment.

Fig. 28

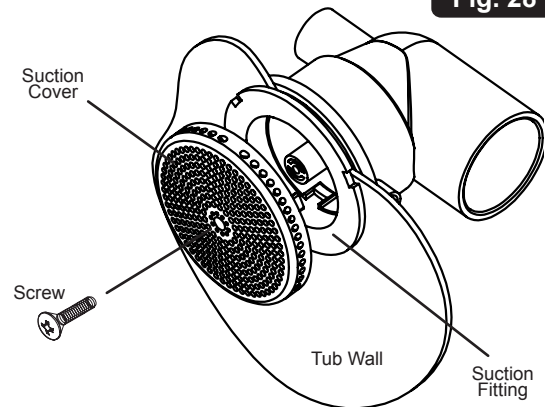

Troubleshooting Procedures

Symptoms	Problems	Solutions
Motor will not start	GFCI or breaker in OFF position Disconnected or defective wiring	Reset GFCI or breaker Check and reconnect if needed
Breaker trips repeatedly	Short between bath and breaker GFCI or breaker defective	Check for short in wiring Replace GFCI or breaker
Motor does not reach full speed	Low voltage Wiring too small	Contact an electrician Contact an electrician
Motor overheats	Low voltage Wiring too small Inadequate ventilation	Contact an electrician Contact an electrician Create ventilation to motor
Leaking around pump	Loose unions O-ring missing	Hand tighten unions Replace O-ring
No pressure from back jets	Jet is closed position	Turn jet face ½-turn counter clockwise
Hot or cold water does not run	Debris in line	Flush lines clean and reinstall cartridge faucet. Technical support:1-844-883-2839

NOTES

If the unit is within the warranty period, contact Ristorre Service Support at 1-844-883-2839 with your bath's serial number before work is started. The serial number is located on the Specification/Serial Number Label (the label is located on the wall of the bathtub near the blower and/or motor).

WIT Reference Diagrams

Combination Models (3137/5230/5433/6030)

Fig. 29

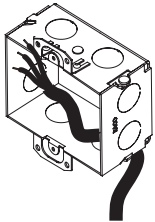
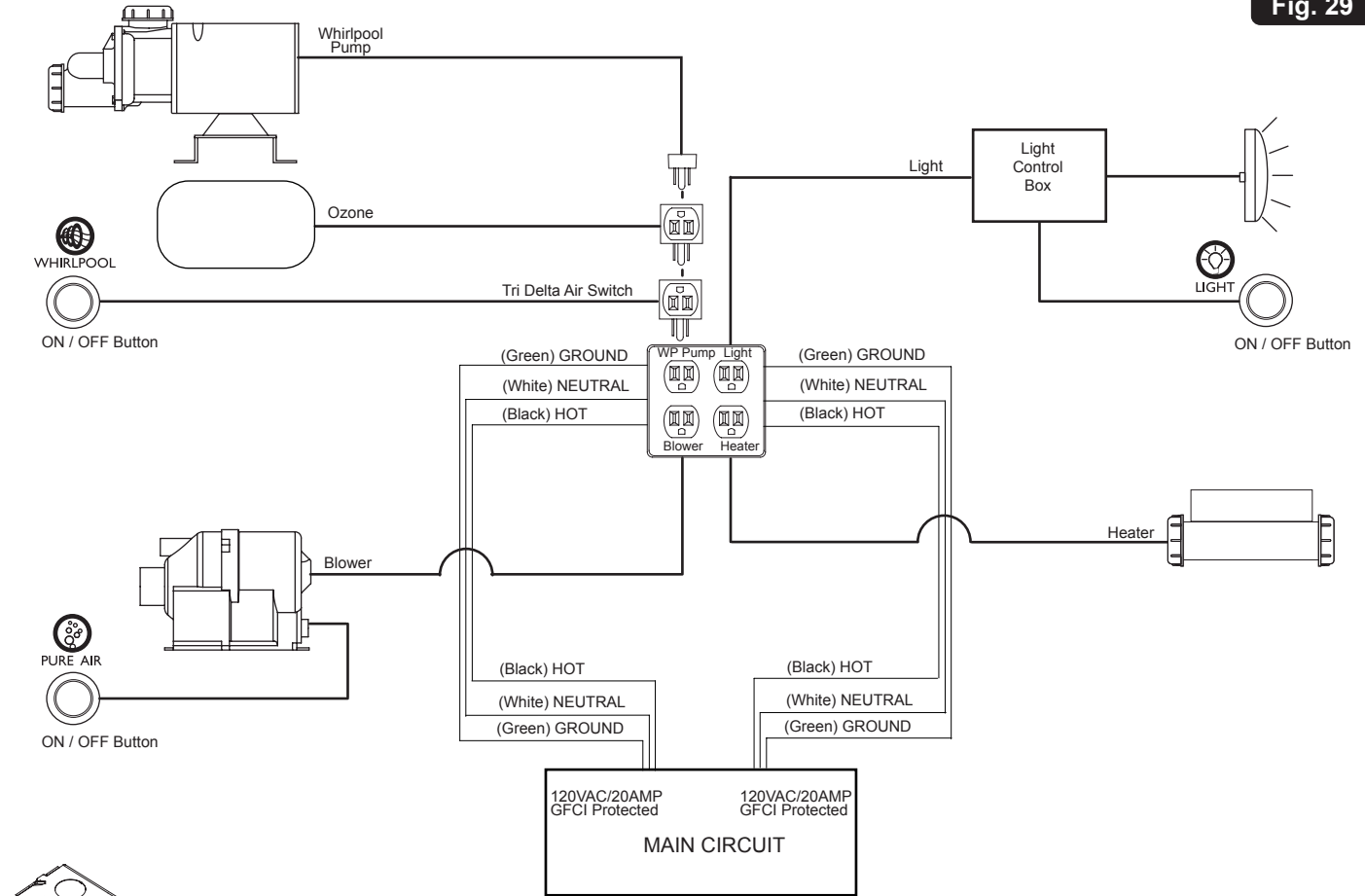

NOTE

CANADIAN MODELS ONLY:
The components must be hardwired in the J-Boxes (supplied) that are located on the unit.

Whirlpool Models (5230/5433/6030)

Fig. 30

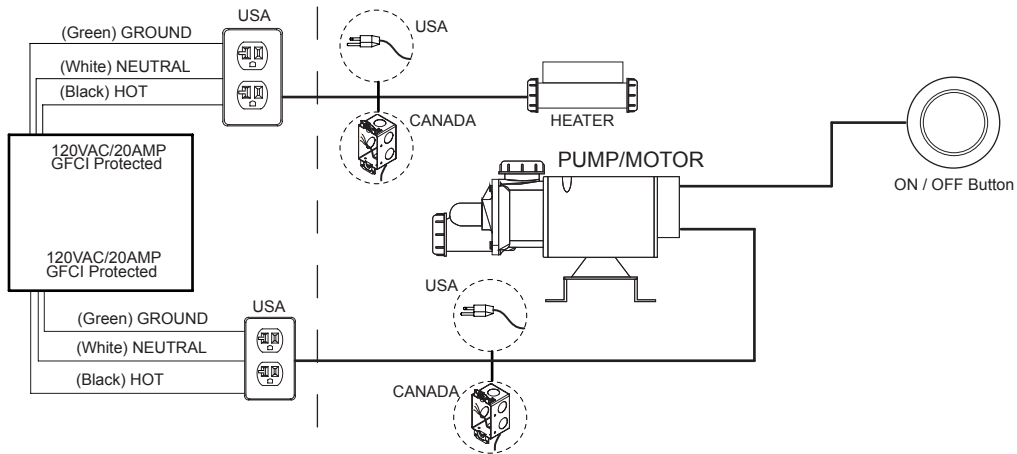

NOTE

Electrical J-Box purchased separately.

Authorized Service

If you need a referral for a service company near you, or need assistance with operation or maintenance-related questions, please call our Service Support Department at 1-844-883-2839. Visit our website at <http://www.ristorre.com/> for products, services, and an online copy of these Installation and Operation Instructions.

When requesting service or technical assistance please have available both the model and serial number of your unit. This information can be obtained from the product registration card provided with your unit. If the card has been misplaced, this information can be obtained from the specification/serial number label on the unit itself. The label is located on the wall of the bathtub near the blower and/or motor.

SPECIFICATION/SERIAL NUMBER LABEL

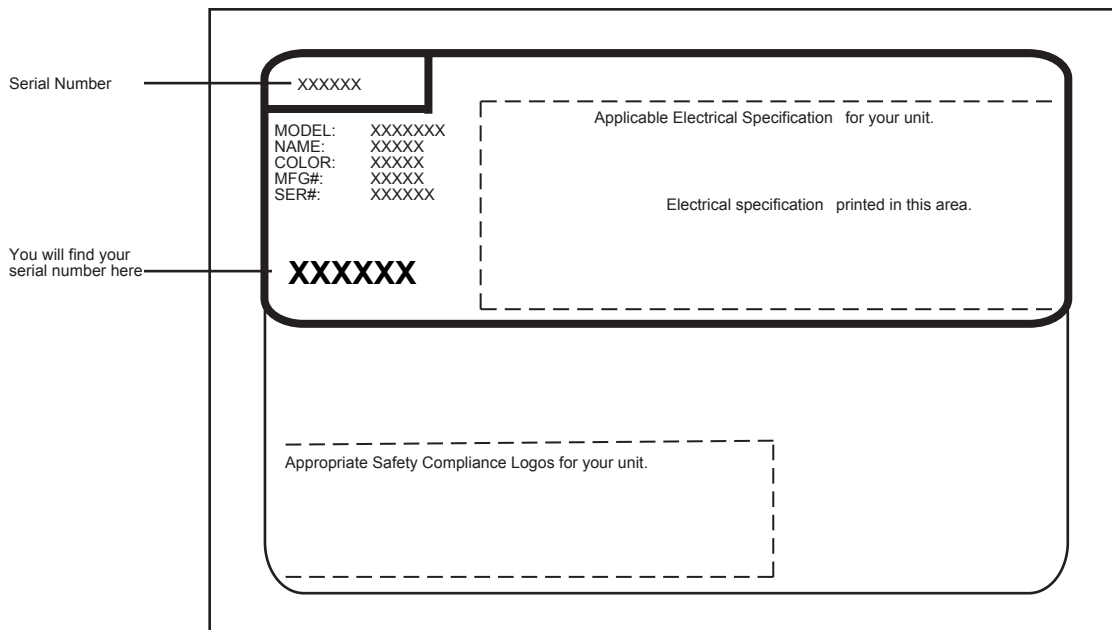

PRODUCT SPECIFICATIONS ARE SUBJECT TO CHANGE WITHOUT NOTICE.
USE TECHNICAL SPECIFICATIONS MANUAL SUPPLIED WITH PRODUCT

Ristorre has obtained applicable code (standards) listings generally available on a national basis for products of this type. It is the responsibility of the installer/owner to determine specific local code compliance prior to installation of the product. Ristorre makes no representation or warranty regarding, and will not be responsible for any code compliance.

Ristorre
14525 Monte Vista Avenue
Chino, California, 91710
1-844-883-2839
www.ristorre.com

Limited Warranty on Ristorre™ Branded Baths

WARRANTY COVERAGE

Ristorre (the "Company") offers the following limited warranty to the original purchaser ("User") of a Ristorre™ model 6030/5230/5433/3137 Walk-In Bath. Please read this entire Limited Warranty, as exclusions and conditions apply. The Company will repair or replace, at its sole option, the Bath or any of its covered equipment in accordance with the following terms and conditions. This warranty does not apply to non Ristorre™ branded bath products manufactured by the Company.

LIMITED LIFETIME WARRANTY ON BATHS SHELL AND SPECIFIC COMPONENTS

The Company extends to the User of the Bath a non-transferable limited lifetime warranty that the shell will maintain its structural integrity and configuration and be free of water loss due to a defect in the bathtub shell. This warranty covers only the bathtub shell and the manufacturer installed pump, jets, controls, and blower against defects in material or workmanship, and does not include labor. This warranty does not apply to any display models or to any options or accessories. Warranty coverage begins on the date the unit was originally purchased by the User. Please register your bathtub within 30 days of delivery.

1 YEAR LIMITED LABOR WARRANTY FOR FACTORY INSTALLED COMPONENTS

Company's limited labor warranty is for a period of one (1) year from the date the unit was originally purchased by the User, but not more than two (2) years from date of manufacture (which can be found on the product ID label), whichever is earlier. Labor warranty only covers labor charges associated with the repair or replacements of factory installed components (e.g., pump, motor, blower, and plumbing) due to defects in materials and workmanship. The labor warranty covers service of the bathtub, but does not cover removal or reinstallation of the bathtub, if removal and reinstallation is needed to perform the repair.

NINETY DAY (PARTS ONLY) LIMITED WARRANTY ON OPTIONS AND ACCESSORIES

Company provides a limited repair and replacement warranty on Ristorre provided options and accessories purchased with a Ristorre™ bathtub for ninety (90) days (LABOR IS NOT COVERED). The limited warranty covers options and accessories manufactured by other companies (e.g., drain fill spout kits, trim kits, skirts, optional heaters and other third party options and accessories) against defects in material or workmanship. Warranty coverage begins on the date the option or accessory was originally purchased by the User with a Ristorre™ tub. These items may be covered by warranty offered by the manufacturer of the option or accessory which may have longer duration than this limited warranty. Please confirm with the manufacturer the duration of the appropriate warranty for options and accessories.

WARRANTY LIMITATIONS

Company's limited warranty does not cover defects, damage, or failure caused by a common carrier, installer, User, or other person, pet, or rodent, or resulting from, without limitation, any of the following: careless handling (e.g., lifting unit by plumbing, abrading finish, etc.); modification of any type whatsoever made to the product, option or accessory for any reason (including but not limited to modification to meet local codes and any deletion or addition to the Bath); improper installation (including installation not in accordance with instructions and specification provided with the unit); connections supplied by the installer of the equipment; improper voltage supply or unauthorized electrical modification; misuse; incorrect operation, or lack of proper routine maintenance; operation of the unit without specified minimum amount of water or at inappropriate water temperature; use of abrasive or improper cleaners; or acts of God, such as lightning, floods earthquakes, etc.

IN ADDITION, THE COMPANY EXPRESSLY DISCLAIMS AND WILL NOT BE RESPONSIBLE FOR INCIDENTAL OR CONSEQUENTIAL DAMAGES OR LOSSES ARISING FROM ANY CAUSE (E.G., WATER DAMAGE TO CARPET, CEILING, TILES, MARBLE, LOSS OF USE, ETC.) INCLUDING ITS OWN NEGLIGENCE; DAMAGES TO, RESPECTING, OR RESULTING FROM PLATED PARTS WHEN POOL AND/OR SPA CHEMICALS ARE USED IN THE UNIT, DAMAGE CAUSED BY HARD WATER CONDITIONS; OPTIONAL BATH EQUIPMENT NOT MANUFACTURED BY THE COMPANY BUT SUPPLIED BY DEALER, INSTALLER OR THE COMPANY; THE UNIT'S PRIOR USAGE AS AN OPERATIONAL DISPLAY; OR DEFECTS THAT SHOULD HAVE BEEN DISCOVERED BEFORE INSTALLATION.

This limited warranty does not include: labor, transportation, or other costs incurred in the removal and/or reinstallation of the original unit and/or installation of a replacement unit; any costs relating to obtaining access for repair; or loss of use damage, including loss of sales, profit or business advantage of any kind under any circumstances. Warranty coverage is provided in the United States of America and Canada only.

EXCLUSION OF IMPLIED WARRANTIES

IMPLIED WARRANTIES OF MERCHANTABILITY AND FITNESS FOR A PARTICULAR PURPOSE ARE EXPRESSLY DISCLAIMED ALTOGETHER OR TO THE FULLEST EXTENT ALLOWED BY LAW.

NOTICE: This warranty gives you specific legal rights, and you may also have other rights which vary from state to state. This Limited Warranty takes the place of all other warranties, express or implied, in fact or at law. There are no other warranties applicable to Ristorre™ products. The Company will not be responsible for any statements or representations made in any form that go beyond, are broader than or are inconsistent with any authorized literature or specification furnished by the Company. Some states do not allow limitations on how long an implied warranty lasts, disclaimer of certain warranties, or the exclusion or limitation of incidental or consequential damages, so some of the above limitations and exclusions may not apply to you.

RETURN OF WARRANTY REGISTRATION

To register your product, complete the registration card below and mail it to Ristorre at the address provided. Please return your product registration within 30 days of delivery.

RESPONSIBILITIES OF OTHERS

Inspecting the unit prior to installation is the responsibility of the installer or building contractor who acts on behalf of the User. They are responsible for ensuring the unit is free of defect or damage. Notices are placed on and in the unit and on the shipping carton advising the installer of this responsibility. In the event of a problem, the unit must not be installed. THE COMPANY IS NOT RESPONSIBLE FOR FAILURES OR DAMAGE THAT COULD HAVE BEEN DISCOVERED, REPAIRED, OR AVOIDED BY PROPER INSPECTION AND TESTING (INCLUDING PROPER WATER TESTING) PRIOR TO INSTALLATION.

Damage occurring in transit is the responsibility of the carrier. The User or installer MUST open the crate and inspect the unit for damage when it is delivered. If damage is discovered, it must be reported immediately to the seller and the carrier in writing, and an inspection requested. Failure of the carrier to respond should be reported to the seller and the carrier. Any freight claims should be filed promptly thereafter.

Damage occurring to the unit during installation is the responsibility of the installer and/or building contractor and damage occurring during or after installation is the responsibility of the User.

Failure of any optional equipment is the sole responsibility of the equipment manufacturer except as provided above, and this warranty shall not extend to or apply to any replacement parts for the Options and Accessories. Warranty for any replacement parts shall be covered by the equipment manufacturer only.

The Distributor or Dealer (not Company) is responsible for knowing local code requirements and notifying the installing contractor and/or User of these requirements at the time of purchase. The Company is not responsible for costs to modify any product to obtain any code approval, such as city, county, or state building codes in U.S.A. or municipal or provincial codes in Canada.

WARRANTY SERVICE

For the User's benefit the Company maintains a list of independent service personnel to perform required warranty service repairs. Such firms are not agents or representatives of the Company and cannot bind the Company by words or conduct.

The Company will provide the warranty service described above when the following conditions have been met: the failure is of the nature or type covered by the warranty; the User has informed an Authorized Ristorre™ Service Agent or Warranty Service Department Representative of the nature of the problem during the warranty period; conclusive evidence (e.g., proof of purchase or installation) is provided to the foregoing by the user proving that the failure occurred or was discovered within the warranty period; and an authorized independent service person or Company representative has been permitted to inspect the unit during regular business hours within a reasonable time after the problem was reported by the User. In order to obtain warranty service, contact Ristorre at:

www.ristorre.com
or
Ristorre
Warranty Service Department
14525 Monte Vista Avenue
Chino, California 91710
Call: (844) 883-2839

To obtain warranty replacement for factory-installed components of Company supplied options and accessories manufactured and supplied by the Company, call or write the above. Provide a description of the problem and proof of purchase. You will be instructed how to obtain replacements and where to return, at your expense, the failed component(s), option(s), or accessory(ies).

All replacement parts, equipment, and repairs shall assume the remaining warranty period of the part(s) replaced.

The Company's warranty obligation shall be discharged upon tender of replacement or repair, at Company's sole discretion. The customer's refusal to accept the tender terminates the Company's warranty obligation.

Ninety-Day
Parts Only
Limited Warranty
On
Accessory(ies)



Ristorre
14525 Monte Vista Avenue
Chino, California 91710

Ristorre™ WARRANTY REGISTRATION CARD

A JACUZZI COMPANY

To complete your registration fill out and mail this card to the address printed on the other side within thirty (30) days from date of purchase in order for this warranty to become effective.

Purchaser's Name _____

Purchaser's Address _____

City _____ State __ Zip _____

Home Phone: _____

Cell Phone: Email: _____

Date of Purchase _____

Model Name _____

Serial Number _____

Dealer's Name _____

Dealer's Address _____

1. How did you first hear about this Ristorre™ product?

- Advertisement Article in Magazine/Newspaper
- Visited Dealer/Plumbing Supplier Yellow Pages
- Builder/Plumber/Remodeler Decorator/Architect
- Visited Retailer/Home Center Store
- Word of Mouth . . . Friend/Relative/Acquaintance
- Other (Please Describe) _____

2. Who first gave you specific information about this product (specifications prices, etc.)?

- Dealer/Plumbing Supplier Builder Remodeler
- Plumbing Contractor Retailer/Home Center Store
- Decorator/Architect Already Installed

3. What was the main reason for purchase?

- Styling Warranty Service Product Features
- Brand Name Price Hydrotherapy
- Home Resale _____
- Other _____

4. Who finally decided which product you would buy?

- Self Spouse Self and Spouse Together Other Family Member Designer/Architect
- Builder/Plumber/Remodeler Already Installed

5. Who installed? Already installed/New Home

- Contractor/Plumber when remodeling
- Self/Spouse when remodeling
- Other _____

6. What is the current market value of this property?

Please estimate \$ _____

7. What is the age of the head of the household? Years _____

8. What other manufacturers did you consider?

- Eljer Lasco Price Pfister Aqua Glass
- Kohler American Standard Sterling
- Other (Specify) _____

9. How long did you shop before purchasing unit?

- 1 day 2 months- 6 months
- 2-7 days 6 months- 1 year
- 1 week- 2 weeks 1 year- 2 years
- 2 weeks- 4 weeks +2 years
- 1 month- 2 months

10. Approximately how long have you lived in this home _____?

11. Please indicate, approximately, the total annual income of your household.

- Up to \$24,999 \$50,000 to \$74,999
- \$25,000 to \$29,999 \$75,000 to \$99,999
- \$30,000 to \$39,999 \$100,000 to \$149,999
- \$40,000 to \$49,999 \$150,000 and Above

12. Was your purchase process?

- Very easy Easy Difficult Very Difficult



Ninety-Day
Parts Only
Limited Warranty
On
Accessory(ies)

Ristorre™
RS21000