

11" SOFT-CLOSE PULLOUT WITH BLUM TANDEM SLIDES WITH BLUMOTION

TOOLS REQUIRED:

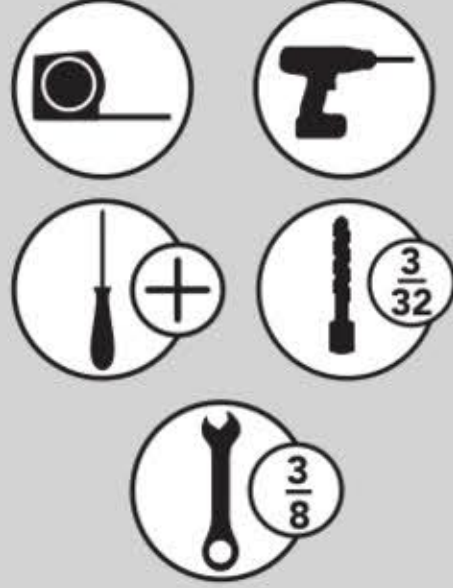

ESTIMATED ASSEMBLY TIME:

30 MIN

CARE AND MAINTENANCE:

Clean with a damp cloth and wipe parts dry.

PARTS LIST

- Frame/Slide Assembly
- (4) #6 x 1/2" Flat Head Screws
- (4) #8 x 3/4" Deep Thread Pan Head Screws
- Template
- Rub Bushing Kit

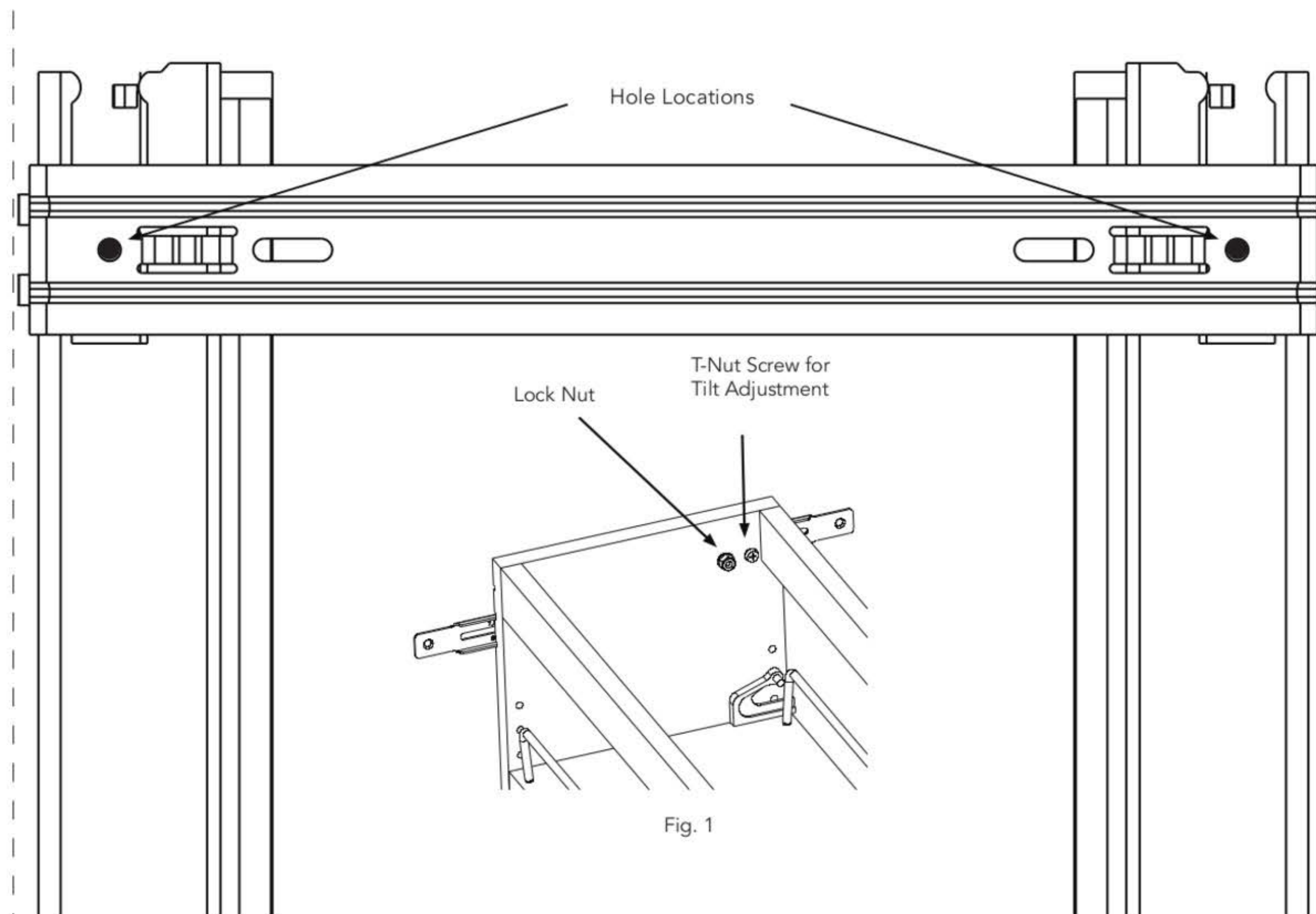

Attaching slide to cabinet

- 1) Use the hole locations on the template to pre-drill (4) holes using a 3/32" drill bit.
- 2) Remove template and attach the slide assembly to the floor of the cabinet using (4) #8 x 3/4" deep thread pan head screws provided.
- 3) With the slides in the fully closed position, place the frame on the slides and push back until you feel the slides engage the locking devices (you will hear a click sound). Fully cycle the unit a few times.

Attaching the cabinet door

- 1) Loosen the (4) lock nuts (3/8" wrench) inside the front wall of the unit (See Fig. 1).
- 2) Position the Adjustable Door Mounting Brackets to ensure that you are mounting to the "thick" portion of the cabinet door (Front of pullout should line up with front of face frame).
- 3) Use the (4) #6 x 1/2" flat head screws provided to attach the door to the pullout unit.
- 4) If the door needs to be adjusted to lay flush against the face frame, loosen the 8 mm lock nut and turn the "T-Nut" screw. Re-tighten 8 mm lock nut. Each corner can be adjusted independently. (Note: It is recommended that door bumpers be used on each corner to ensure quiet operation)

Install rub bushings using enclosed kit and instructions (Note: Chassis may need to be removed for proper installation)

