

This drawing is the property of Rev-A-Shelf (RAS) and is disclosed in confidence to the extent its subject matter is original to RAS. Any vendor receiving this drawing from RAS shall hold and use this drawing for the sole benefit of RAS and shall not disclose it to, or use or reproduce it for any third party, or perform any act adverse to the interest of RAS with respect to this drawing without the express written permission of RAS. Vendors shall not revise any physical, dimensional or performance characteristic unless authorized by Rev-A-Shelf Engineering.

REV.	DATE	BY	DESCRIPTION OF CHANGE

INCH [MM]	AMERICAN PROJECTION	DRAWN	BY	DATE	REV-A-SHELF, INC.
		LKW	LKW	7-9-19	
TOLERANCES					DRAWING NO.
MAT.	DEC.	ANGLES		SCALE	
(WOOD)	.XX ±.03 [.8mm]	±1/2°		0.200	
(OTHER)	.XX ±.02 [.5mm]			PART NO.	
(ALL)	.XXX ±.005 [.13 mm]				4WBDP18-25
FRACTIONS ±1/32 [.8 mm]					SHEET OF
					1 2

CUSTOMER DRAWING

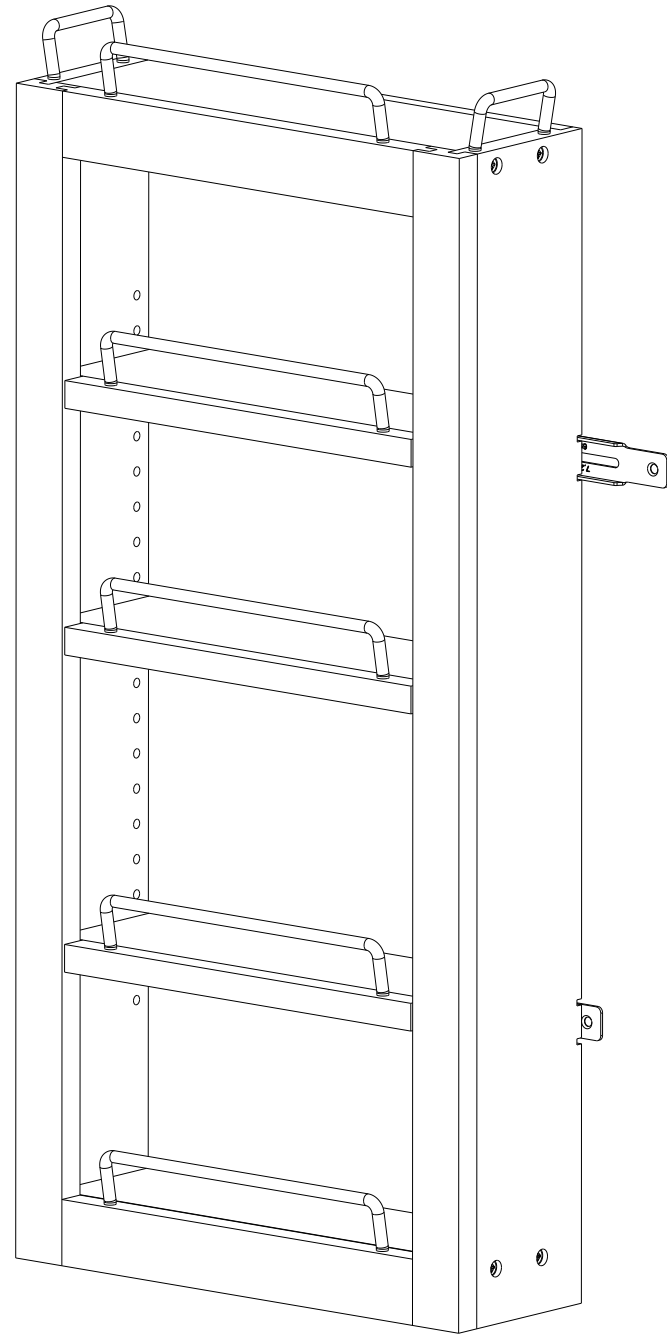

PART DIMENSIONS	
WIDTH	12.00 [304,8]
DEPTH	4.00 [101,6]
HEIGHT *	25.00 [635]

\* HEIGHT W/ TOP RAILS: 26.20 [665,4]

MIN CABINET OPENING				
	FACE FRAME	FRAMELESS	INSET FACE FRAME	INSET FRAMELESS
WIDTH	15.25 [387]	15.25 [387]	15.25 [387]	15.25 [387]
DEPTH	4.25 [108]	4.25 [108]	5.00 [127]	5.00 [127]
HEIGHT **	25.75 [654]	25.75 [654]	25.75 [654]	25.75 [654]

\*\* IF USING TOP RAILS: 26.75 [679,5]

NOTES:

1. SLIDES: N/A
2. 3 SHELVES ARE ADJUSTABLE
3. BOTTOM SHELF NOT ADJUSTABLE

CUSTOMER DRAWING

This drawing is the property of Rev-A-Shelf (RAS) and is disclosed in confidence to the extent its subject matter is original to RAS. Any vendor receiving this drawing from RAS shall hold and use this drawing for the sole benefit of RAS and shall not disclose it to, or use or reproduce it for any third party, or perform any act adverse to the interest of RAS with respect to this drawing without the express written permission of RAS. Vendors shall not revise any physical, dimensional or performance characteristic unless authorized by Rev-A-Shelf Engineering.

REV.	DATE	BY	DESCRIPTION OF CHANGE

INCH [MM]	AMERICAN PROJECTION	DRAWN	BY	DATE	REV-A-SHELF, INC.
			LKW	7-9-19	
TOLERANCES		MATERIAL	DRAWING NO.		SCALE
MAT.	DEC.		FINISH	4WBDP18-25	
(WOOD) .XX ±.03 [8mm]	(OTHER) .XX ±.02 [5mm]	PART NO.		SHEET OF	
(ALL) .XXX ±.005 [13 mm]	FRACTIONS ±1/32 [8 mm]	4WBDP18-25		2 2	
ANGLES ±1/2°					

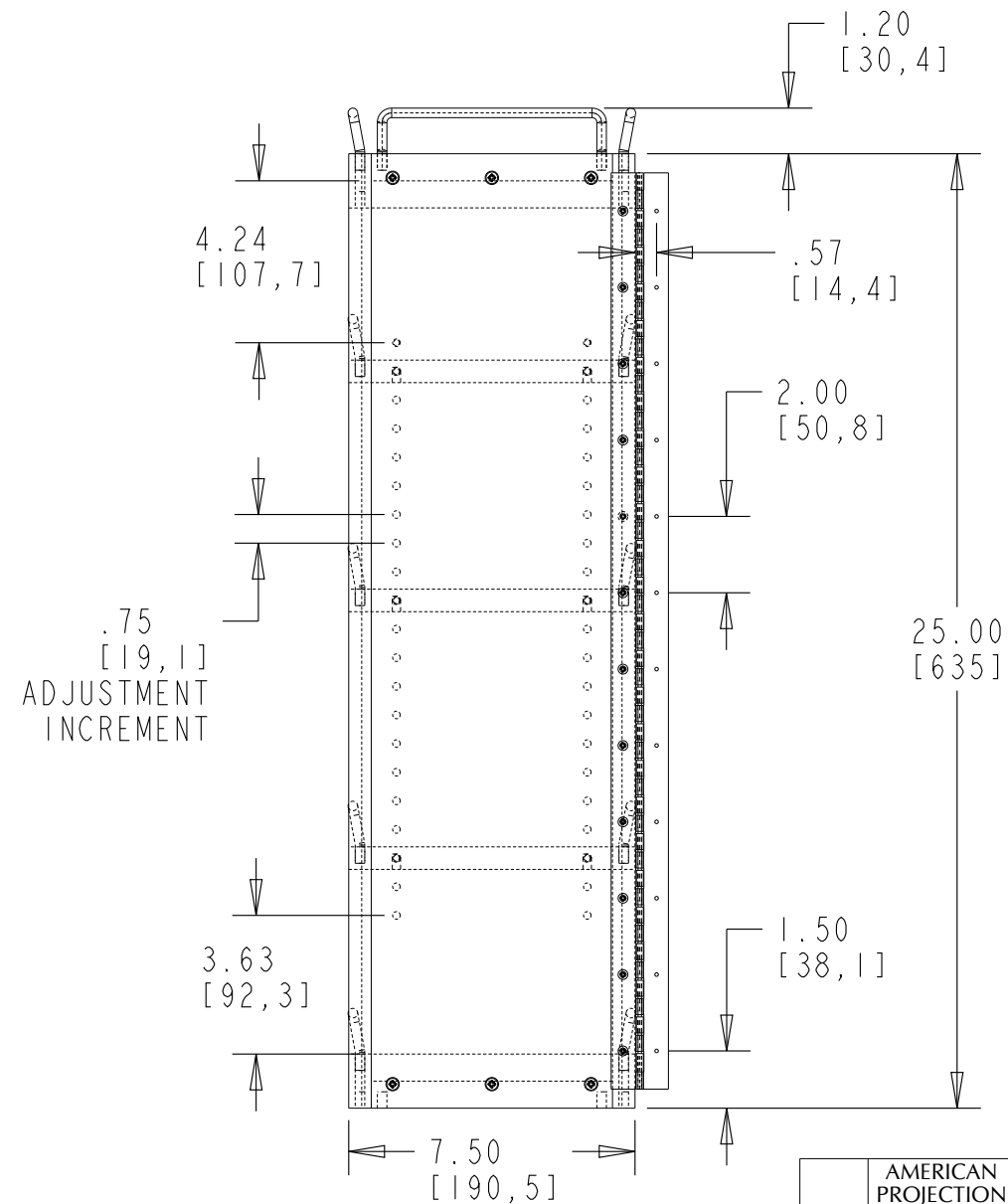
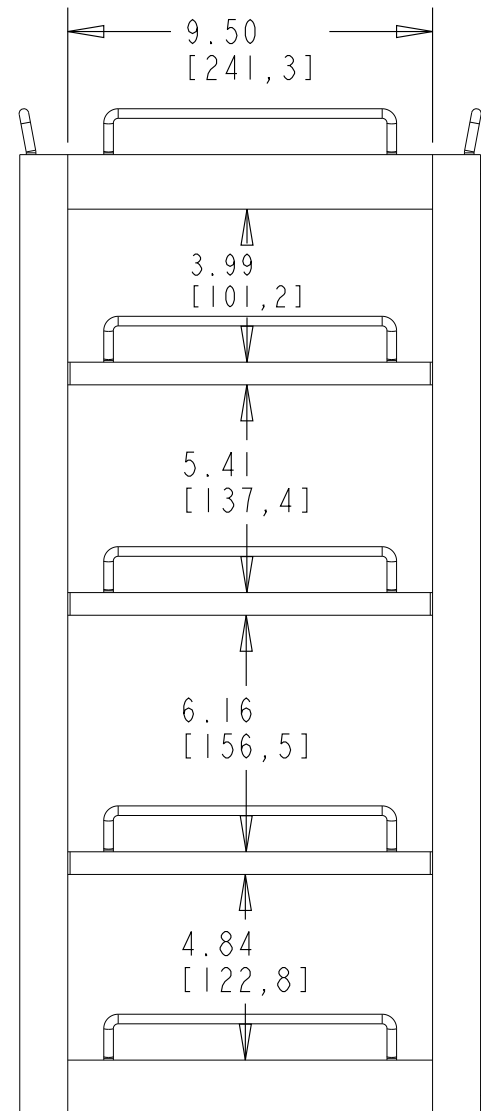
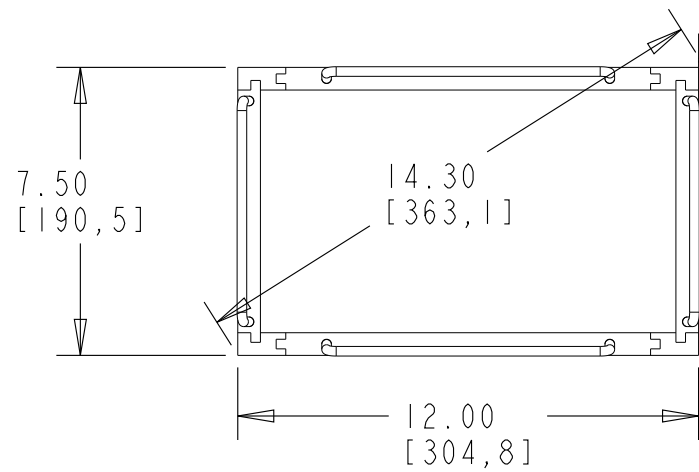

CUSTOMER DRAWING

This drawing is the property of Rev-A-Shelf (RAS) and is disclosed in confidence to the extent its subject matter is original to RAS. Any vendor receiving this drawing from RAS shall hold and use this drawing for the sole benefit of RAS and shall not disclose it to, or use or reproduce it for any third party, or perform any act adverse to the interest of RAS with respect to this drawing without the express written permission of RAS. Vendors shall not revise any physical, dimensional or performance characteristic unless authorized by Rev-A-Shelf Engineering.

REV.	DATE	BY	DESCRIPTION OF CHANGE

INCH [MM]	AMERICAN PROJECTION 	DRAWN	BY	DATE	REV-A-SHELF, INC.
			LCS	8/03/22	
					SIZE B
					25" PANTRY SWING OUT SINGLE WOOD UNIT WITH HARDWARE
					DRAWING NO. 4WBSP18-25
					SCALE 0.200
					PART NO. 4WBSP18-25
					SHEET OF 1 2

TOLERANCES  
 MAT. DEC.  
 (WOOD) .XX ±.03 [.8mm]  
 (OTHER) .XX ±.02 [.5mm]  
 (ALL) .XXX ±.005 [.13 mm]  
 FRACTIONS ±1/32 [.8 mm]

ANGLES  
±1/2°

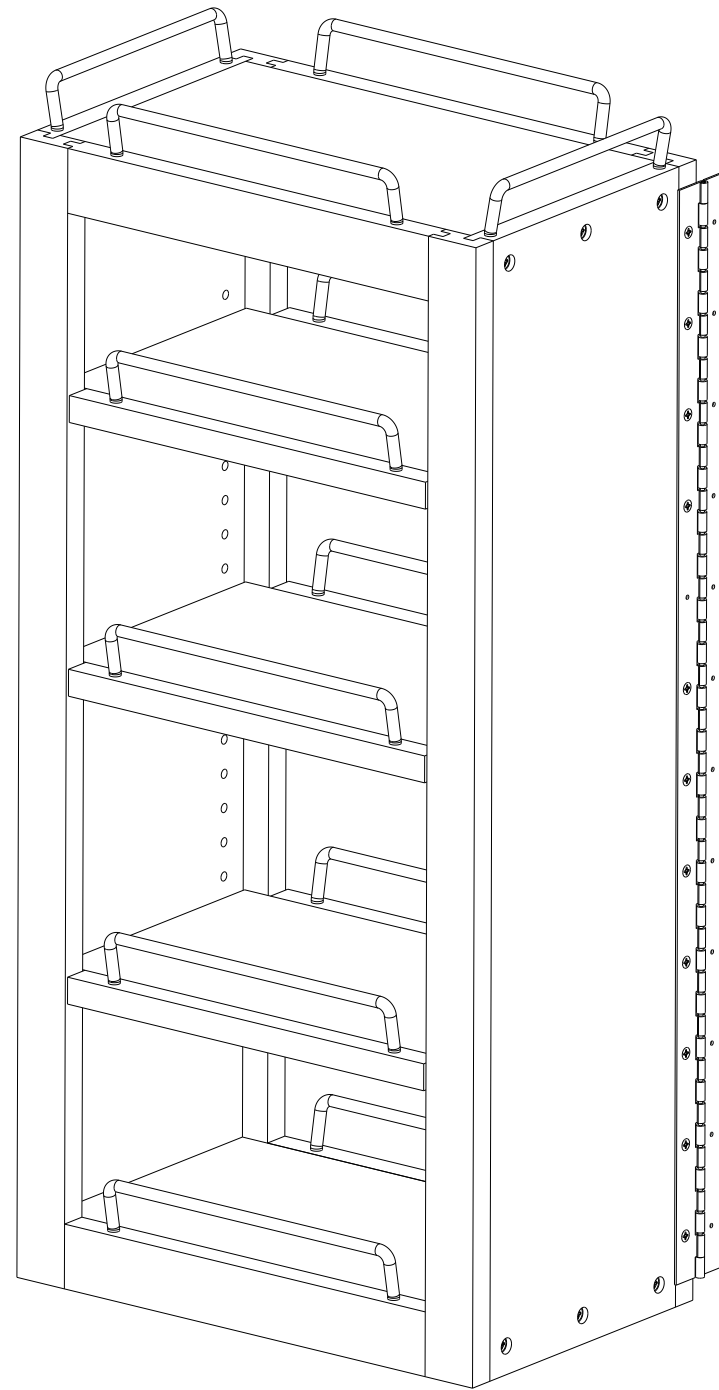

PART DIMENSIONS	
WIDTH	12.00 [304,8]
DEPTH	7.50 [190,5]
HEIGHT *	25.00 [635]

\* HEIGHT W/ TOP RAILS: 26.20 [665,4]

MIN CABINET OPENING				
	FACE FRAME	FRAMELESS	INSET FACE FRAME	INSET FRAMELESS
WIDTH	33.00 [838]	33.00 [838]	33.00 [838]	33.00 [838]
DEPTH	7.75 [197]	7.75 [197]	8.50 [216]	8.50 [216]
HEIGHT **	25.75 [654]	25.75 [654]	25.75 [654]	25.75 [654]

\*\* IF USING TOP RAILS: 26.75 [679,5]

NOTES:

1. SLIDES: N/A
2. 3 SHELVES ARE ADJUSTABLE
3. BOTTOM SHELF NOT ADJUSTABLE

CUSTOMER DRAWING

This drawing is the property of Rev-A-Shelf (RAS) and is disclosed in confidence to the extent its subject matter is original to RAS. Any vendor receiving this drawing from RAS shall hold and use this drawing for the sole benefit of RAS and shall not disclose it to, or use or reproduce it for any third party, or perform any act adverse to the interest of RAS with respect to this drawing without the express written permission of RAS. Vendors shall not revise any physical, dimensional or performance characteristic unless authorized by Rev-A-Shelf Engineering.

REV.	DATE	BY	DESCRIPTION OF CHANGE

INCH [MM]	AMERICAN PROJECTION 	DRAWN	BY	DATE	REV-A-SHELF, INC.
		LCS		8/03/22	
TOLERANCES		MATERIAL	DRAWING NO.		SCALE
MAT.	DEC.		4WBSP18-25		
(WOOD)	.XX ±.03 [.8mm]	FINISH	PART NO.		SHEET OF
(OTHER)	.XX ±.02 [.5mm]		4WBSP18-25		
(ALL)	.XXX ±.005 [.13 mm]				
FRACTIONS	±1/32 [.8 mm]				