

Please go to www.quoise.com for product cleaning tips. Go to the **Care + Maintenance** selection.

Tools Required: Flathead screwdriver, Phillips screwdriver, pliers, wire cutters, wire strippers, electrical tape, safety glasses.

Light Source: (4) B10 Candelabra Base bulbs 60W Maximum.

Estimated Assembly Time: 20-30 minutes

Preparation: Identify and inspect all parts before beginning installation. Check package content list and diagrams below to ensure all parts are present. If any parts are missing or damaged, do not attempt to assemble, install, or operate the fixture. Contact customer service for replacement parts.

Fixture can only be mounted in the direction indicated on page 2.

⚠ Warnings and Cautions

Turn off electricity at circuit breaker or main fuse box before installation. Consult a licensed electrician if in doubt.

These instructions are provided for your safety. It is very important you read them completely before installing the fixture. We strongly recommend that a licensed, professional electrician perform the installation.

Disconnect fixture from power source before replacing bulbs. Make sure bulbs are given sufficient time to cool before removal.

Package Contents

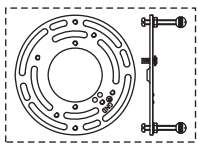

A Crossbar Assembly x 1

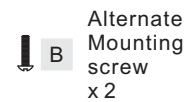

B Alternate Mounting screw x 2



C Glass Panel x 4

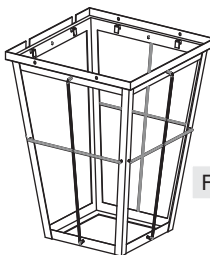

F Cage x 1

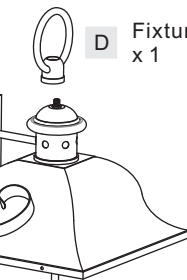

D Fixture Loop x 1

E Fixture Body x 1



G Allen Screw x 4

STEP 2 – Assemble Glass Panels and Cage

- Insert the Glass Panel (C) into the Cage (F). Place the short edge of the Glass Panel (C) into the slot in the bottom edge of the Cage (F). Fold tabs on the top edge of the Cage (F) to secure the top edge of the Glass Panel (C). Repeat this process to complete all Glass Panels (F).
- Align Channels on the top of Cage (F) to the studs inside of the fixture hood. Place the fixture hood and Fixture Body (E) onto the Cage (F) and secure with Allen Screws (G). Tighten gently until snug with screwdrivers.

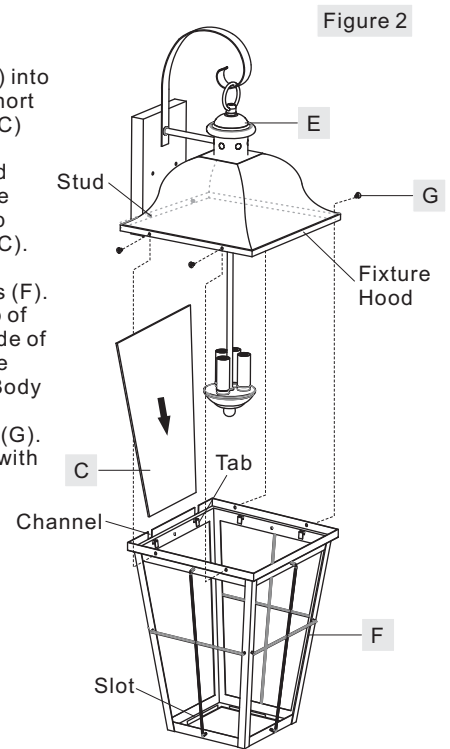

Figure 2

STEP 1 – Assemble Fixture Loop and Flat Scroll

- Thread the Fixture Loop (D) onto the nipple on the top end of the Fixture Body (E). Hand tighten until snug.
- Rotate the flat scroll to the top of the Fixture Body (E). Pull the scroll end of the flat scroll and insert it into the Fixture Loop (D).

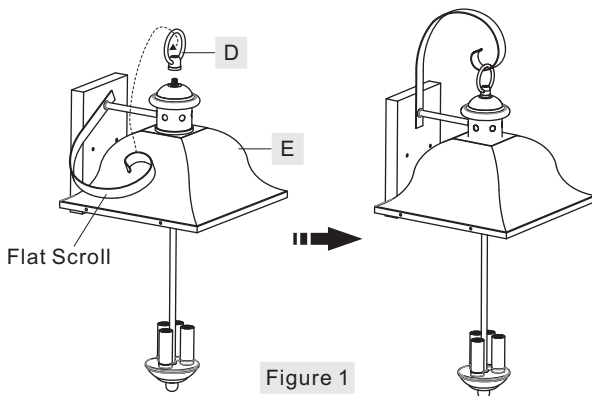

Figure 1

STEP 3 – Installing the Crossbar Assembly

- Pass the supply wires through the Crossbar Assembly (A). Attach the Crossbar Assembly (A) to the Outlet Box with the head of the Green Ground Screw facing you. Secure the Crossbar Assembly (A) with Outlet Box Screws (not included). Tighten until snug. **Note:** Use the Alternate Shorter Mounting Screw (B) if your installation requires a shorter mounting screw.

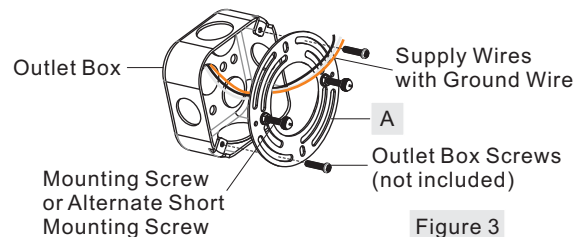

Figure 3

Thank you for purchasing a Quoizel product.
Need assistance with parts or assembly? Call Quoizel customer service at 1-800-645-3184
or visit us on-line at www.quoise.com

STEP 4 – Test Fit the Backplate to the Crossbar Assembly

A. Remove the mounting balls from the Crossbar Assembly (A). Place the backplate and Fixture Body (E) onto the Crossbar Assembly (A) and secure with mounting balls. Note: The backplate and Fixture Body (E) should be snug against the wall and held tight with the mounting balls. If it is not, adjust the length of the mounting screw or alternate short mounting screw on the Crossbar Assembly (A) by unscrewing the preassembled hex nut and lock washer and then screwing the mounting screws or alternate short mounting screws in or out of the crossbar until the correct length is achieved. Once the backplate and Fixture Body (E) is secure, remove the mounting ball and Fixture Body (E) and proceed to Step 5.

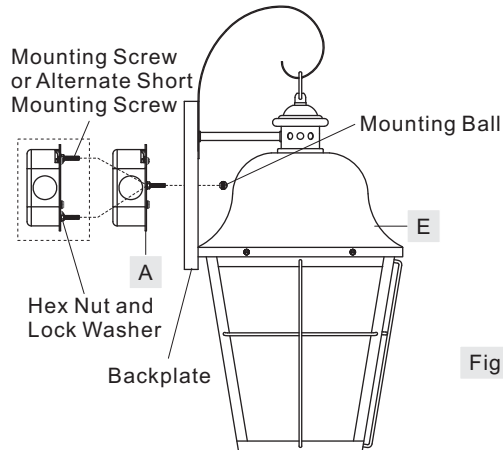

Figure 4

STEP 5 - Wire Connections

A. Wrap bare or green ground wire around green ground screw on the crossbar, no less than 2 inches from the end of the wire. Tighten the green ground screw.
 B. Use standard wire connectors (not included) to make all wire connections. Twist connectors until wires are tightly joined together. Wrap each connection with approved electrical tape and carefully stuff all the connected wires into the Outlet Box.

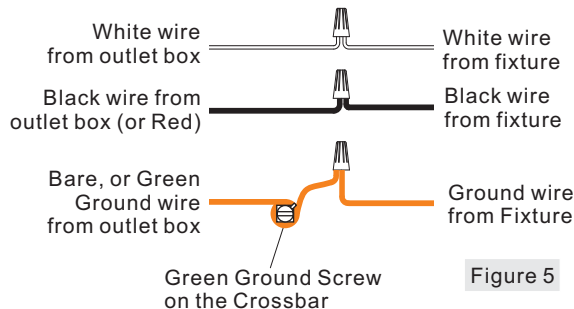

Figure 5

STEP 6 – Install the Fixture Body

A. Position the backplate and Fixture Body (E) onto the Crossbar Assembly (A). Place the holes in the backplate over the mounting screws or alternate short mounting screws. Secure the Fixture Body by using the mounting balls and hand tighten the mounting balls until snug.

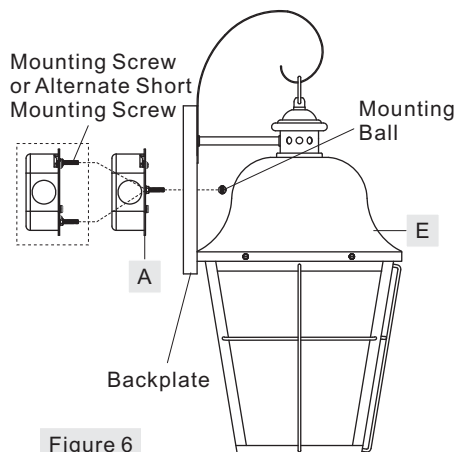

Figure 6

STEP 7 – Install Bulbs and Apply Silicone Sealer

A. Insert bulbs onto sockets and screw snugly into place.
 B. Make sure the exterior wall surface and fixture backplate are free of dirt before applying caulk. Using exterior grade caulk, caulk over top of backplate and down both sides. Do not caulk the bottom of the fixture backplate to ensure proper moisture drainage.

Your fixture is now assembled and ready to use. Enjoy!

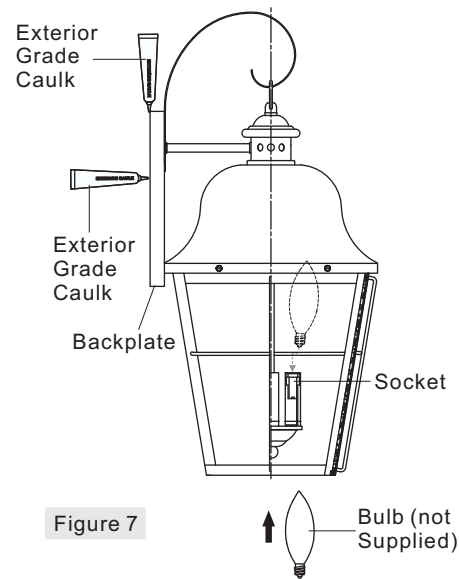
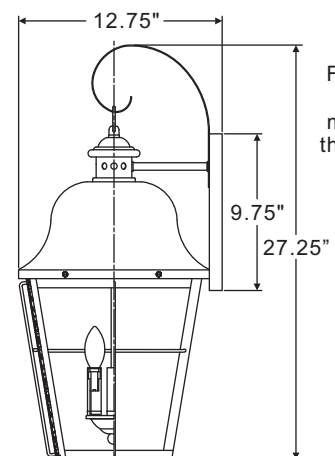
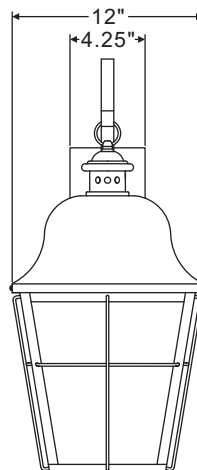
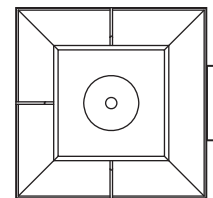
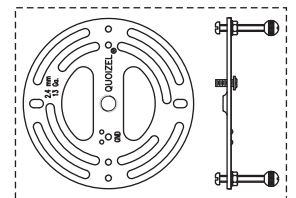

Figure 7

MHE8412CU
 FINISH: COPPER BRONZE



↑
 Fixture can only be mounted in the direction indicated

NOTE: ALL DIMENSIONS ARE ROUNDED UP TO THE NEAREST 1/4"

Thank you for purchasing a Quoizel product.
 Need assistance with parts or assembly? Call Quoizel customer service at 1-800-645-3184 or visit us on-line at www.quoise.com