

Please go to [www. quozel. com](http://www. quozel. com) for product cleaning tips. Go to the **Care + Maintenance** selection.

**Tools Required:** Flathead screwdriver, Phillips screwdriver, pliers, wire cutters, wire strippers, electrical tape, safety glasses.

**Bulb Recommended:** (3) LED G9 4.5W Bulbs

**Estimated Assembly Time:** 20-30 minutes

**Preparation:** Identify and inspect all parts before beginning installation. Check package content list and diagrams below to be sure all parts are present. If any parts are missing or damaged, do not attempt to assemble, install, or operate the fixture. Contact customer service for replacement parts.

Please go to [Quozel. com](http://Quozel. com) to see the G9 LED bulb specifications provided with your fixture.

## ⚠ Warnings and Cautions

Turn off electricity at circuit breaker or main fuse box before installation. Consult a licensed electrician if in doubt.

These instructions are provided for your safety. It is very important you read them completely before installing the fixture. We strongly recommend that a licensed, professional electrician perform the installation.

Disconnect fixture from power source before replacing bulbs. Make sure bulbs are given sufficient time to cool before removal. Do not subject glass parts to any shock while in operation or shattering may result.

## Package Contents

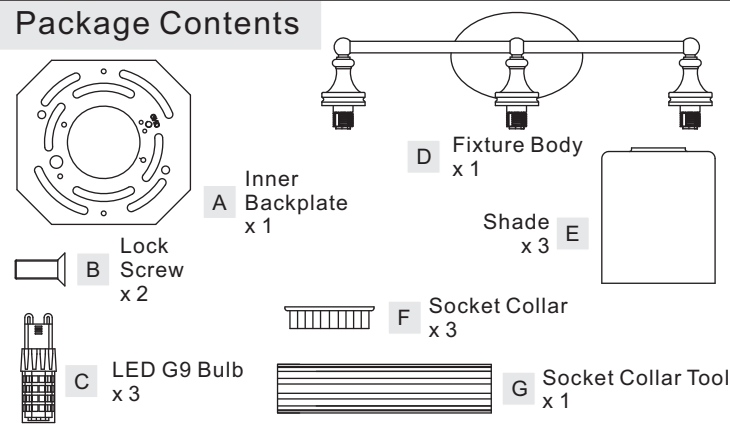

## STEP 3 - Install Fixture Body

A. Place the backplate of the Fixture Body (D) onto the Inner Backplate (A) and secure with Lock Screws (B). Hand tighten until snug with screwdrivers.

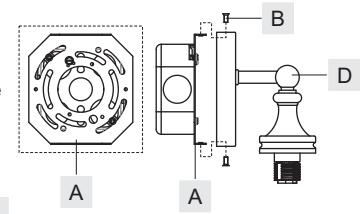

Figure 3

## STEP 4 - Install Shade

A. Place Shade (E) over Socket as shown. By using the Socket Collar Tool (G), thread the Socket Collar (F) onto the socket to secure the Shade (E). Hand tighten until snug.

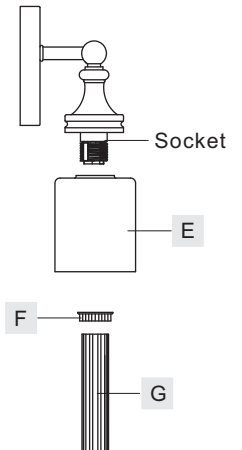

Figure 4

## STEP 1 - Install Inner Backplate

A. Race all supply wires through the Inner Backplate (A) as shown. Attach Inner Backplate (A) to Outlet Box with the head of Green Ground Screw facing you. Secure it with Outlet Box Screws (not included). Tighten until snug.

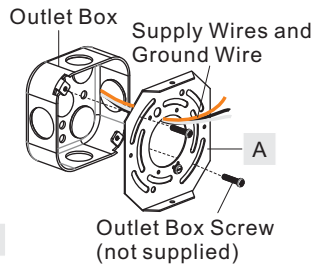

Figure 1

## STEP 2 - Wire Connections

A. Use standard wire connectors (not included) to make all wire connections. Twist connectors until wires are tightly joined together. Wrap each connection with approved electrical tape and carefully stuff all the connected wires between Inner Backplate (A) and Fixture Body (D).

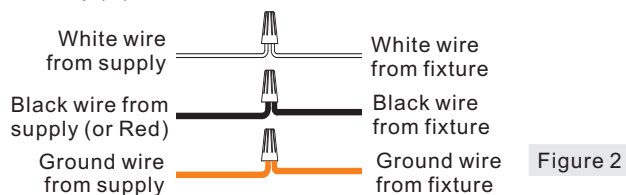

Figure 2

## STEP 5 - Install Bulb

A. Install either the G9 Xenon bulb as specified (not provided) or install the G9 LED bulbs (provided) if the fixture purchased is the LED model.

**Note:** This fixture is rated to use 60W maximum G9 Xenon bulbs. You may use a lower wattage G9 Xenon or if you purchased the LED model it is supplied with G9 LED bulbs.

Your fixture is now assembled and ready to use. Enjoy!

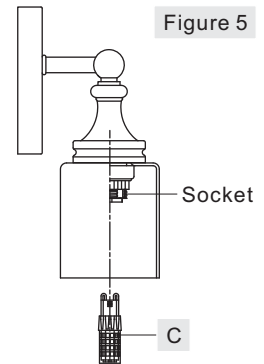
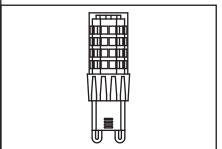
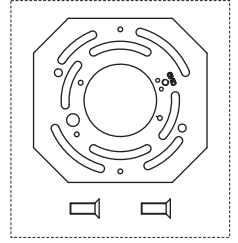
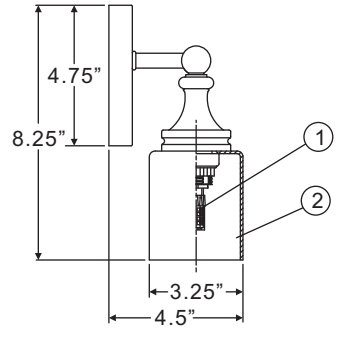
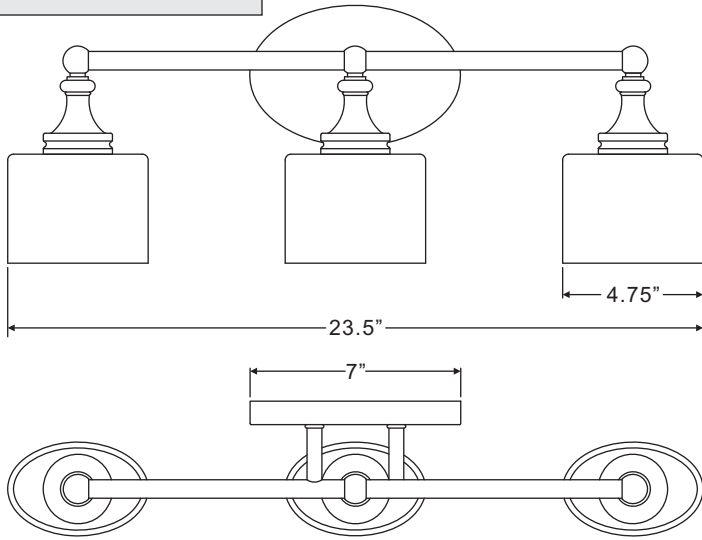

Figure 5

Thank you for purchasing a Quozel product.  
Need assistance with parts or assembly? Call Quozel customer service at 1-800-645-3184  
or visit us on-line at [www. quozel. com](http://www. quozel. com)

QI8603CLED	QI8603HOLED
FINISH: POLISHED CHROME	FINISH: HARBOR BRONZE



(3) 4.5W Maximum LED G9 Bulbs

NOTE: ALL DIMENSIONS ARE ROUNDED UP TO THE NEAREST 1/4"

NO.	PART NUMBER	REPLACEMENT PART DESCRIPTION	QTY.
1	I12442LED	BULB 4.5W LED G9 DIM WHITE	3
2	G1911SH	SHADE	3

Thank you for purchasing a Quoizel product.  
 Need assistance with parts or assembly? Call Quoizel customer service at 1-800-645-3184  
 or visit us on-line at [www.quoise.com](http://www.quoise.com)