

Please go to [www. quozel. com](http://www. quozel. com) for product cleaning tips. Go to the **Care + Maintenance** selection.

**Tools Required:** Flathead screwdriver, Phillips screwdriver, pliers, wire cutters, wire strippers, electrical tape, safety glasses.

**Light Source:** (1) Medium Base Decorative Filament 60W bulb (provided), Maximum 150W, Alternate bulb (1) 42W CFL Maximum.

**Estimated Assembly Time:** 20-30 minutes

**Preparation:** Identify and inspect all parts before beginning installation. Check package content list and diagrams below to be sure all parts are present. If any parts are missing or damaged, do not attempt to assemble, install, or operate the fixture. Contact customer service for replacement parts.

**Fixture can only be mounted in the direction indicated on page 2.**

## ⚠ Warnings and Cautions

Turn off electricity at circuit breaker or main fuse box before installation. Consult a licensed electrician if in doubt.

These instructions are provided for your safety. It is very important you read them completely before installing the fixture. We strongly recommend that a licensed, professional electrician perform the installation.

Disconnect fixture from power source before replacing bulbs. Make sure bulbs are given sufficient time to cool before removal. Do not subject glass parts to any shock while in operation or shattering may result.

## Package Contents

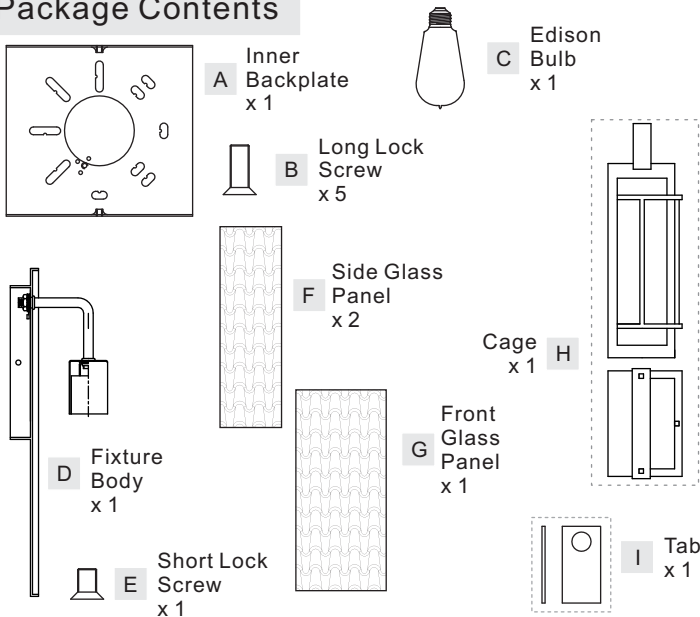

## STEP 2 – Attach Cage onto the Fixture Body

A. Line up the hole on the Cage (H) and the mounting hole on the Fixture Body (D), secure by threading the Lock Screw (B) into the mounting hole on the Fixture Body (D), tighten until snug.

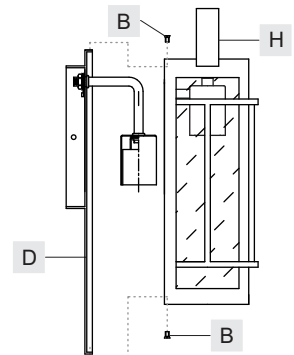

## STEP 3 – Install Inner Backplate and Fixture Body

A. Pass the supply wires through Inner Backplate (A). Attach Inner Backplate (A) to Outlet Box with the head of Green Ground Screw facing you. Secure it with Outlet Box Screws (not included). Tighten until snug.  
B. Race all supply wires through the Inner Backplate (A) as shown. Refer to Step 4 for wiring connections.  
C. Attach the Fixture Body (D) over the Inner Backplate (A). Apply caulks onto Lock Screws (B) and thread Lock Screws (B) into Inner Backplate (A) to secure the fixture. Tighten until snug with screwdrivers.

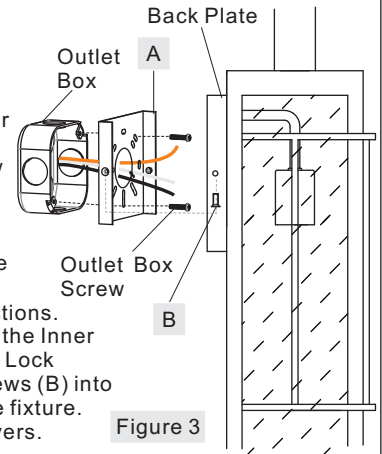

## STEP 1 – Install Glass Panels to the Cage

A. Insert bottom edge of the Front Glass Panel (G) into the Slot in the Cage (H) and attach the Front Glass Panel (G) to the Cage (G). Place the Tab (H) onto the top edge of the Front Glass Panel (G) and thread the Short Lock Screw (E) into the Mounting Hole on the Cage (H) to secure the Front Glass Panel (G). Tighten gently until snug.  
B. Insert Side Glass Panels (F) to the side of the Cage (H) and secure them by folding tabs in the top edge of the Cage (H).

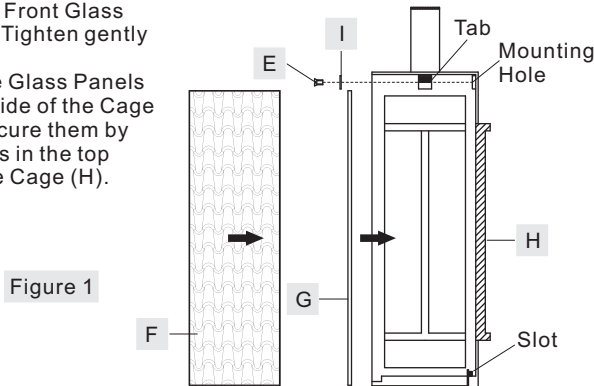

## STEP 4 - Wire Connections

A. Use standard wire connectors (not included) to make all wire connections. (Connectors are not included with fixture.) Twist connectors until wires are tightly joined together. Wrap each connection with approved electrical tape and carefully stuff all the connected wires into the Outlet Box.

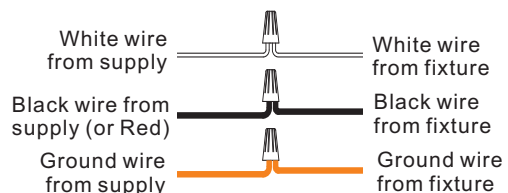

**Thank you for purchasing a Quozel product.**  
**Need assistance with parts or assembly? Call Quozel customer service at 1-631-273-2700**  
**or visit us on-line at [www. quozel. com](http://www. quozel. com)**

**STEP 5 - Install Bulb**

A. This fixture uses Medium Base Decorative Filament 60W bulb (C), Maximum 100W. Insert bulb and screw snugly into place.

Figure 5

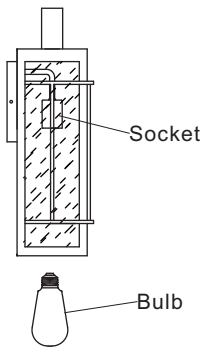

**STEP 6 - Apply Silicone Sealer**

A. Make sure exterior wall surface and fixture backplate are free of dirt before applying caulk. Using exterior grade caulk, caulk over top of backplate and down other side. Do not caulk bottom of fixture backplate to ensure proper moisture drainage.

Your fixture is now assembled and ready to use. Enjoy!

Figure 6

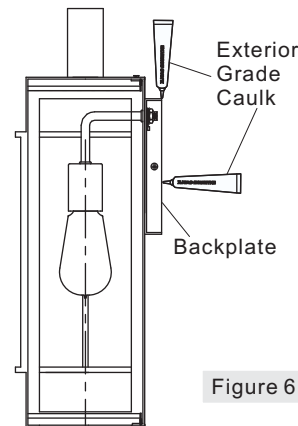

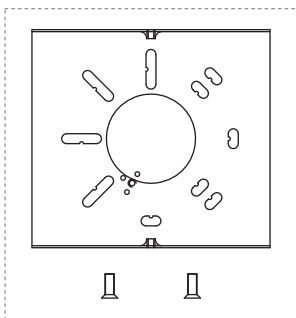

CVW8408WT

FINISH: WESTERN BRONZE

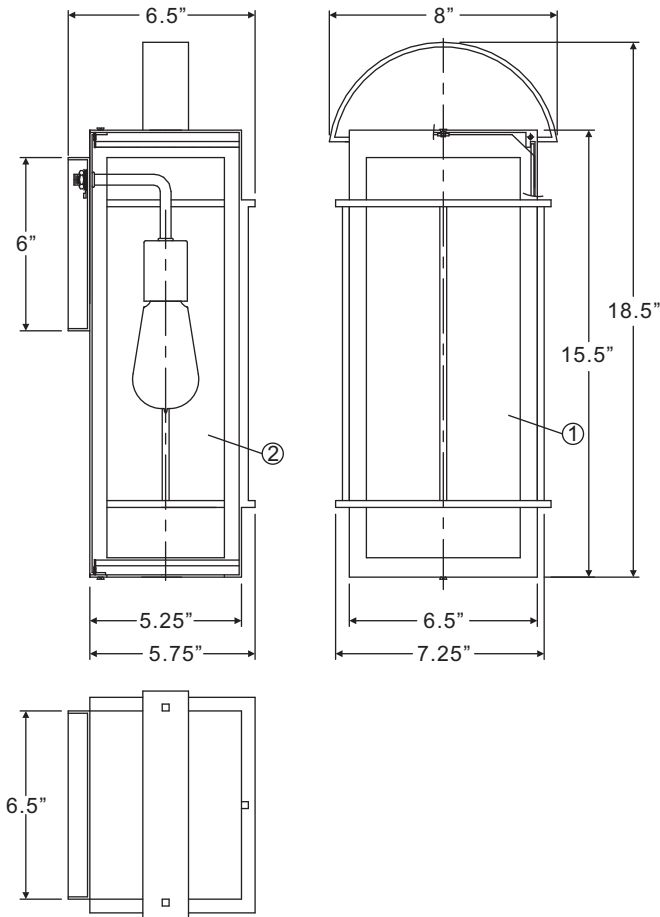

↑  
Fixture can only be mounted in the direction indicated



  
(1) Medium Base Decorative Filament 60W bulbs (provided), Maximum 150W.

NOTE: ALL DIMENSIONS ARE ROUNDED UP TO THE NEAREST 1/4"

NO.	PART NUMBER	REPLACEMENT PART DESCRIPTION	REQ.
1	G12230PA	FRONT GLASS PANEL	1
2	G12229PA	SIDE GLASS PANEL	2

Thank you for purchasing a Quoizel product.  
Need assistance with parts or assembly? Call Quoizel customer service at 1-631-273-2700 or visit us on-line at [www.quoise.com](http://www.quoise.com)