

Please go to [www. quozel. com](http://www. quozel. com) for product cleaning tips. Go to the **Care + Maintenance** selection.

**Tools Required:** Flathead screwdriver, Phillips screwdriver, pliers, wire cutters, wire strippers, electrical tape, safety glasses.

**Light Source:** LED 16W

**Estimated Assembly Time:** 20-30 minutes

**Preparation:** Identify and inspect all parts before beginning installation. Check package content list and diagrams below to be sure all parts are present. If any parts are missing or damaged, do not attempt to assemble, install, or operate the fixture. Contact customer service for replacement parts.

### **⚠ Warnings and Cautions**

Turn off electricity at circuit breaker or main fuse box before installation. Consult a licensed electrician if in doubt.

These instructions are provided for your safety. It is very important you read them completely before installing the fixture. We strongly recommend that a licensed, professional electrician perform the installation.

Disconnect fixture from power source before replacing bulbs. Make sure bulbs are given sufficient time to cool before removal. Do not subject glass parts to any shock while in operation or shattering may result.

### **Package Contents**

- A** Mounting Screw x 3

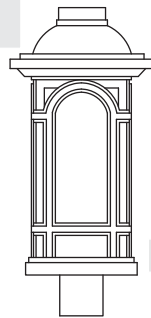

- B** Fixture Body x 1

### **(Step 3 Continued)**

- completely, aligning the holes in the Fitter with the 1/16" Pilot Holes drilled into the Post.  
**B.** Secure the Fixture to Post with (3) Mounting Screws (A).

Your fixture is now assembled and ready to use. Enjoy!

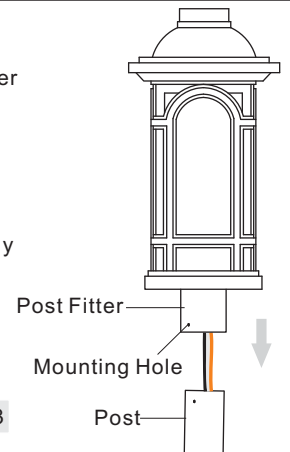

Figure 3

### **STEP 1 – Drill Pilot Holes on Post**

- A.** Carefully fit the Post Fitter over the end of the Post (not supplied), making sure the Post Fitter is fully seated.  
**B.** Mark the drill point for the (3) Mounting Screws, using (3) Mounting Holes as reference. After marking hole locations, remove fixture from post and drill 1/16" pilot holes for screws.

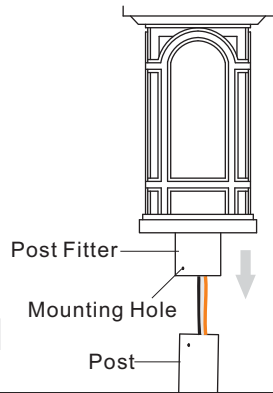

Figure 1

### **STEP 2 - Wire Connections**

- A.** Use standard wire connectors (not included) to make all wire connections. (Connectors are not included with fixture.) Twist connectors until wires are tightly joined together. Wrap each connection with approved electrical tape and carefully stuff all the connected wires into the Outlet Box.

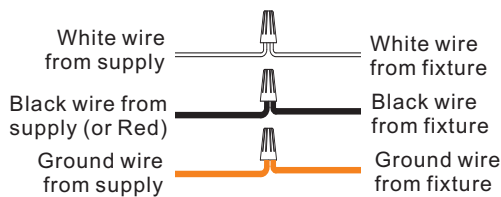

Figure 2

### **STEP 3 – Attach Fixture Body to Post**

- A.** Coat the top 1" of the Post with Clear Silicone Caulk (not supplied) and position the Post Fitter onto the Post. Be sure to seat it

## **HOW TO REPLACE GLASS PANELS**

- A.** Unlock Allen Screws on the Fixture Hood and remove the Fixture Hood from the Cage.  
**B.** Remove Wire Fastener by unscrewing Screws. Separate Quick Connector. Unscrew Screws from the Cage and remove LED Module and Heat Sink.  
**C.** Unscrew Screws from the Cage and remove Glass Holders. Replace Glass Panels from the Cage and then re-install Glass Holders to secure them. Secure with removed Screws.  
**D.** Re-install LED Module and Heat Sink onto the top edge of the Cage. Secure with Screws. Connect Quick Connectors. Re-attach the Wire Fastener and secure with Screws. Attach the Fixture Hood back onto the Cage and secure with Allen Screws.

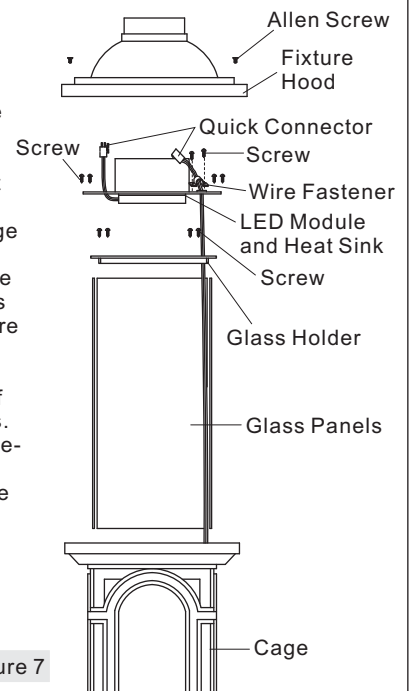

Figure 7

**Thank you for purchasing a Quoizel product.**  
**Need assistance with parts or assembly? Call Quoizel customer service at 1-631-273-2700**  
**or visit us on-line at [www. quozel. com](http://www. quozel. com)**

# HOW TO REPLACE LED MODULE

CATL9011PN

FINISH: PALLADIAN BRONZE



- A. Unlock Allen Screws on the Fixture Hood and remove Cage with Glass Panels from the fixture.
- B. Remove Wire Fastener by unscrewing Screws. Separate Quick Connector. Unscrew Screws from the Cage and remove LED Module and Heat Sink.
- C. Unscrew Lock Screws on the LED Module and remove LED Module from the Board. Attach the replacement LED Module onto the Board. Pass Lock Screws through the replacement LED Module, the Board and the Heat Sink. Secure by threading Hex Nuts onto Lock Screws. Hand tighten until snug. Pass the Quick Connector from the LED Module through the hole on the Heat Sink.
- D. Re-install LED Module and Heat Sink onto the top edge of the Cage. Secure with Screws. Connect Quick Connectors. Re-attach the Wire Fastener and secure with Screws. Attach Cage with Glass Panels back onto the Fixture Hood and secure with Allen Screws.

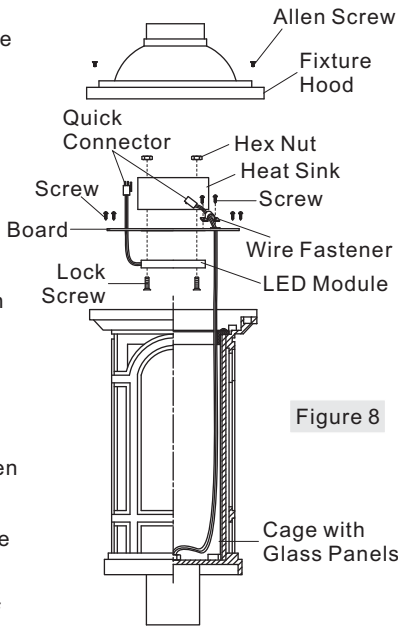
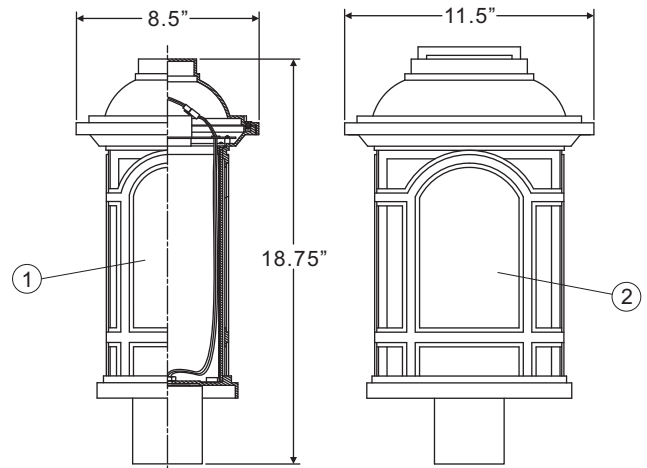

Figure 8



NOTE: ALL DIMENSIONS ARE ROUNDED UP TO THE NEAREST 1/4"

NO.	PART NUMBER	REPLACEMENT PART	REQ.
1	G12217PA	SIDE GLASS PANEL	2
2	G12218PA	FRONT/BACK GLASS PANEL	2

Thank you for purchasing a Quoizel product.  
 Need assistance with parts or assembly? Call Quoizel customer service at 1-631-273-2700  
 or visit us on-line at [www.quoizel.com](http://www.quoizel.com)