

# 3-LIGHT FLUSHMOUNT

## Owner's Manual

Model #51890

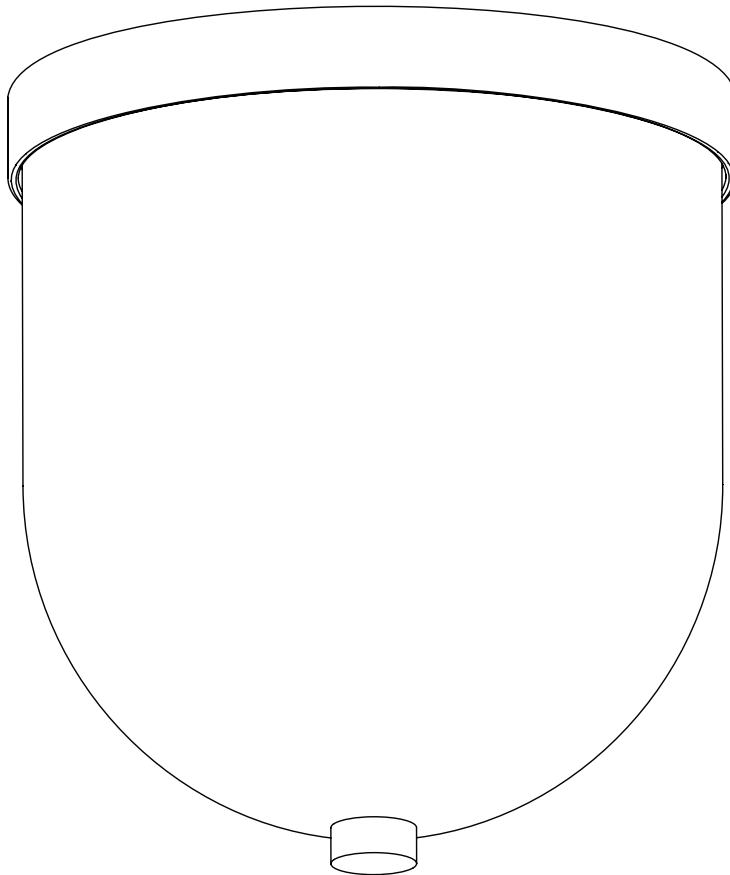

If you have difficulty operating your new light fixture, or have difficulty with installation, please contact  
Customer Service : 1-877-706-3267, 8 a.m. - 5 p.m. Central Time.

## PACKAGE CONTENTS

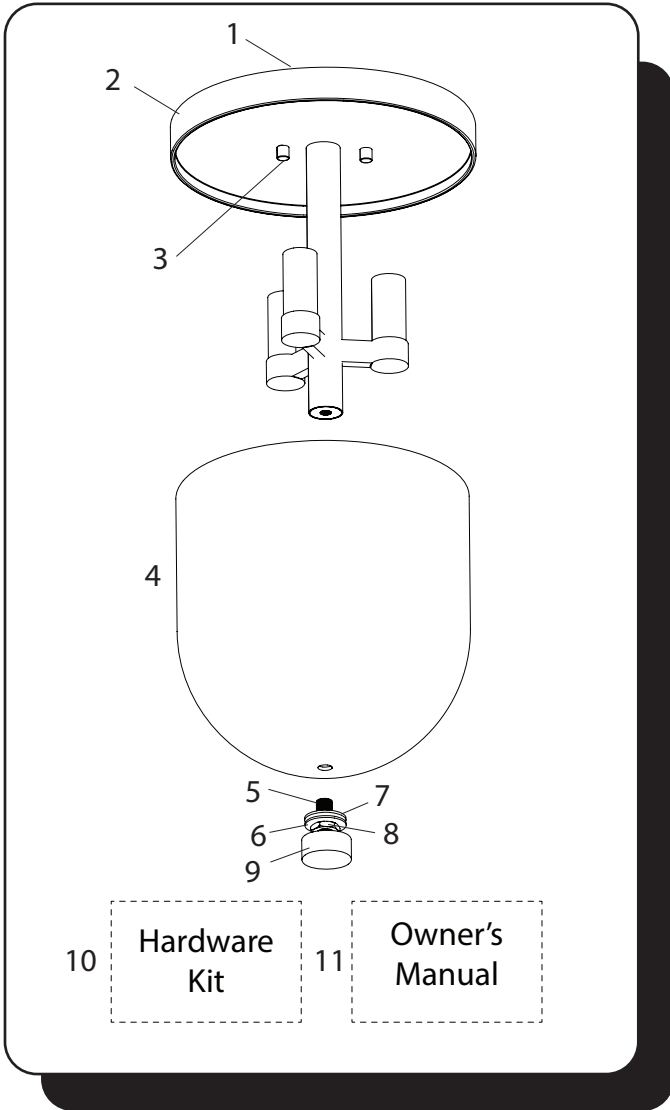

Unpack your fixture and check the contents. You should have the following items:

### PACKAGE CONTENTS

- |                     |                    |
|---------------------|--------------------|
| 1. Mounting Bracket | 7. Rubber Washer   |
| 2. Fixture          | 8. Hex Nut         |
| 3. Screw Cap (x2)   | 9. Finial          |
| 4. Glass Bowl       | 10. Hardware Kit   |
| 5. Threaded Rod     | 11. Owner's Manual |
| 6. Metal Washer     |                    |

### HARDWARE CONTENTS

- |                         |                         |
|-------------------------|-------------------------|
| 12. Wire connector (x3) | 13. Mounting Screw (x2) |
|-------------------------|-------------------------|

## HARDWARE CONTENTS



## TOOLS REQUIRED (not included)

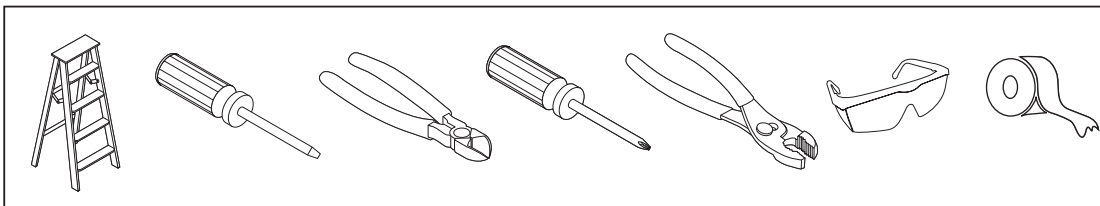

**Tools required for assembly:** Electrical tape, Phillips Screwdriver, Pliers, Safety Glasses, Step Ladder, Wire Cutters and Wire Strippers

**Helpful Tools:** AC Tester Light, Tape Measure, and Wiring Handbook

## SAFETY INSTRUCTIONS

Please read and understand this entire manual before attempting to assemble, operate or install the product. Failure to do so could lead to electrical shock, fire or other injuries that could be hazardous or even fatal.

- Before you begin installing the fixture, disconnect the power by removing fuses or turning off the circuit breakers.
- The net weight of the fixture is 5.32 lb (2,42 kg).
- FOR INDOOR USE ONLY

### **DANGER:**

- DO NOT connect this fixture to an electrical system that does not provide a means for equipment grounding. Never use a fixture in a two-wire system that is not grounded. Installing a fixture into an electrical system not having a proper grounding means could cause metal parts of the fixture to carry electrical currents if any of the fixture wires, wire connections or splices were to become broken, cut or loose during the mounting or normal operation of the fixture. Under this condition, anyone coming in contact with the fixture would be subject to electrical shock, which could cause serious injury or death.
- DO NOT connect the bare or green insulation fixture ground wire to the black (hot) current-carrying wire or the white neutral house wire. Connection of the bare or green fixture ground wire to the black or white house wires may cause metal parts of the fixture to carry electrical currents. Under this condition anyone coming in contact with the fixture will receive electrical shock, which could cause serious injury or death.
- DO NOT damage or cut the wire insulation (covering) during installation of the fixture. DO NOT permit wires to contact any surface having a sharp edge. To do so may damage or cut the wire insulation, which could cause serious injury or death from electrical shock.

### **WARNING:**

- All electrical connections must be in agreement with local codes and ordinances, the National Electric Code (NEC) and ANSI/NFPA 70-1999. Contact your municipal building department to learn about your local codes, permits and/or inspections. Risk of fire - most dwellings built before 1985 have supply wire rated for 140°F. Consult a qualified electrician before installation.
- To avoid personal injury, the use of gloves may be necessary while handling fixture parts with sharp edges.
- DO NOT suspend any fixture by the house wires. A fixture must always be mounted directly to a an outlet box. Wire connectors will not support the weight of a fixture. Suspending a fixture by the house wires and wire connectors will result in the fixture falling, with the possibility of personal injury and the danger of electrical shock or fire.
- To reduce the risk of fire, electrical shock, or personal injury, each wire connector used with this light kit should accept only one 18-gauge wire from the light fixture and one 18-gauge wire from the outlet box. If there are three or more wires to connect or any of the wires is larger than 18 gauges, consult an electrician for the proper size wire connectors to use.

## ASSEMBLY INSTRUCTIONS

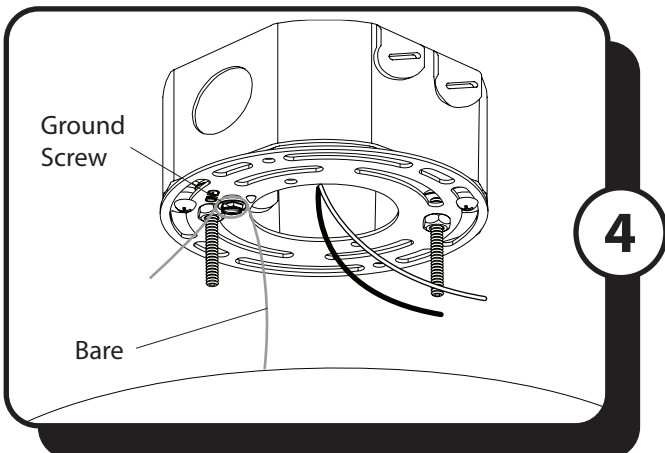
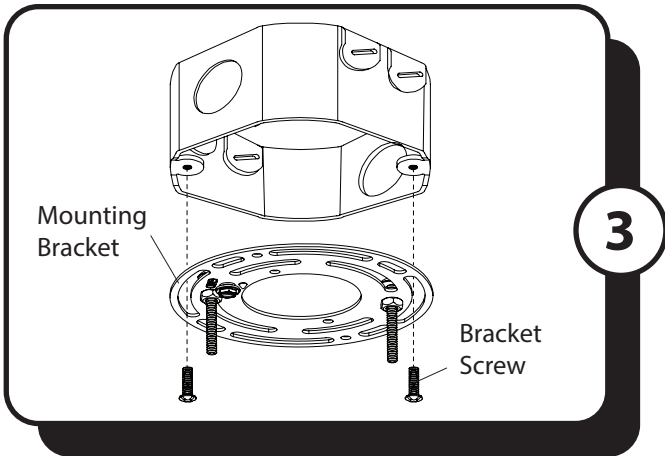
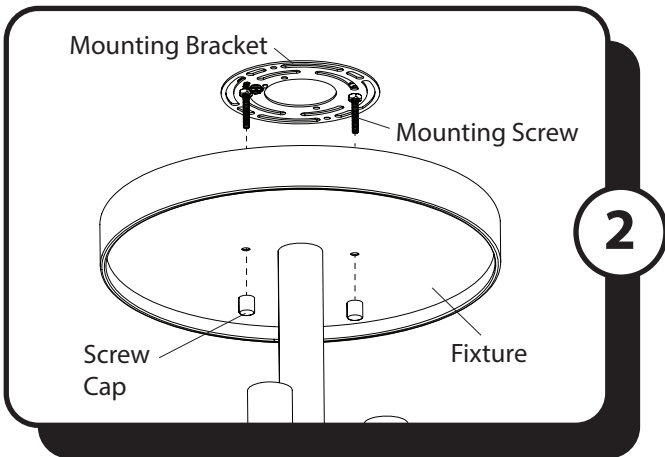
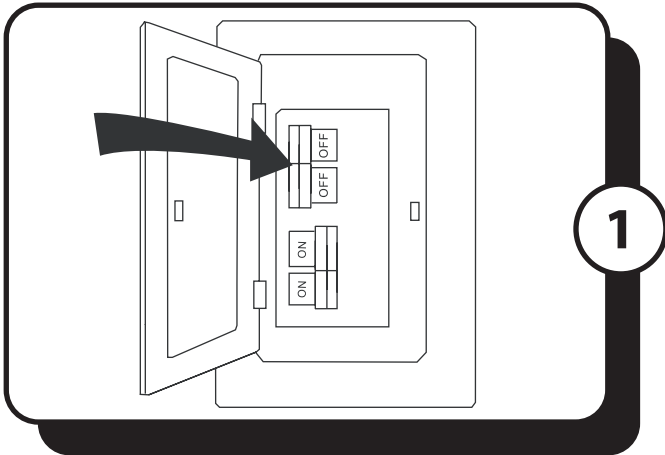

1. Turn OFF the electrical power at the main fuse or circuit breaker.

**DANGER:** Failure to disconnect the power supply prior to installation may result in serious injury or death.

2. Remove the screw caps from the mounting screws preassembled to the mounting bracket. Remove the mounting bracket from the fixture.

3. Use the bracket screws from the hardware bag to attach the mounting bracket securely to the outlet box. Note: Ensure the mounting screws are level since they will determine the orientation of the fixture.

4. Loosen the ground screw on the mounting bracket and wrap the bare wire from the fixture around the ground screw. Tighten the ground screw to hold the bare wire in place. **Note:** Ensure there is enough of the bare wire extending from the ground screw to connect to the ground wire from the outlet box using a wire connector.

## ASSEMBLY INSTRUCTIONS

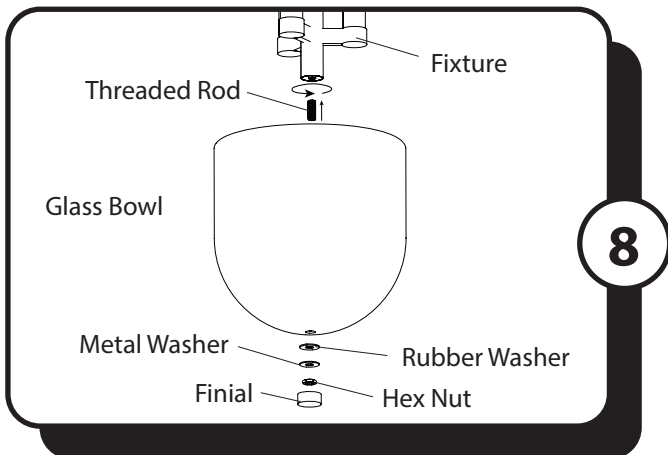
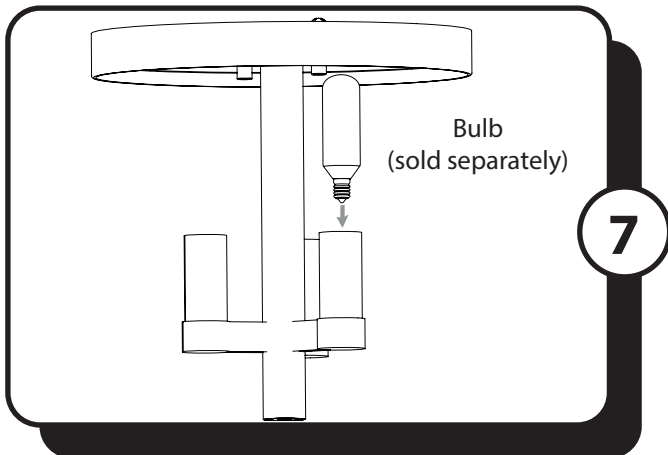
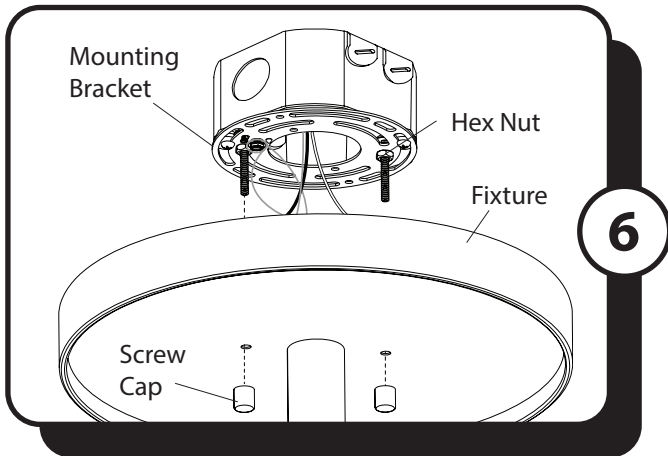
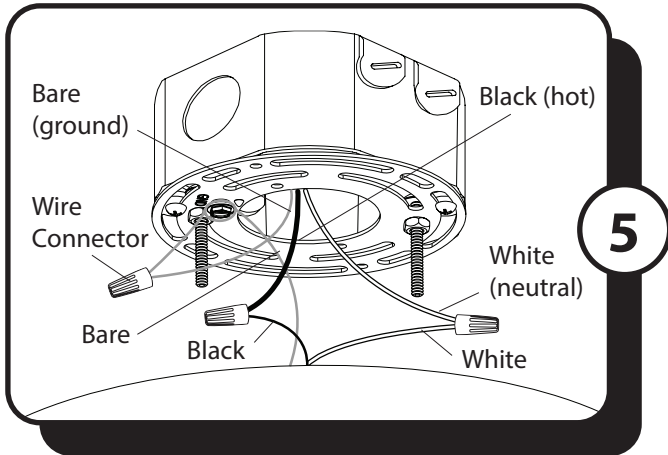

5. Use wire connectors to secure the household supply wires to the fixture wires according to the image and the following instructions:

- Connect the black (hot) supply wire to the black wire from the fixture.
- Connect the white (neutral) supply wire to the white wire from the fixture.
- Connect the bare/green (ground) supply wire to the bare wire from the fixture.

Turn the wire connections and gently push them into the outlet box.

6. Lift the fixture onto the mounting screws preassembled to the mounting bracket. Then use the screw caps to secure the fixture to the mounting bracket.

**Note:** If the fixture is not flush against the ceiling, remove the fixture and loosen the hex nuts to allow the mounting screw length to be adjusted. Once adjusted retighten the hex nuts and reinstall the fixture.

7. Install E12-base bulbs (sold separately) into the sockets of the fixture.

**Note:** Fixture is compatible with any E12-base LED, CFL, or incandescent bulb (60 watt max.). It is not necessary to use Edison-shaped bulbs (shown).

8. Insert the threaded rod onto the bottom of the fixture and turn in a clockwise direction until secure. Lift the center hole in the glass bowl over the threaded rod on the fixture and secure with rubber washer, metal washer, hex nut, and finial.

Restore the power at the main fuse or circuit breaker and the wall switch.

**Assembly is complete.**

## TROUBLESHOOTING

If you have difficulty operating your new light fixture, or have difficulty with installation, please contact CustomerService : 1-877-706-3267, 8 a.m. - 5 p.m. Central Time.

**WARNING:** Ensure the power is turned off to the light fixture before performing any maintenance.

PROBLEM	SUGGESTED REMEDY
1. Fixture does not light up.	1. Ensure power is on at the wall switch and fuses or circuit breakers. 2. Check wire connections. 3. Replace the bulbs.

## WARRANTY

# 1-YEAR LIMITED WARRANTY

To obtain service, please contact Customer Service:  
1-877-706-3267, 8 a.m. - 5 p.m. Central Time.

Model Name: 3-Light Flushmount  
Model No: 51890

The manufacturer warrants all of its light fixtures against defects in materials and workmanship for one (1) year from the date of purchase. If within this period the product is found to be defective, take a copy of the bill of sale as a proof of purchase and the product in its original carton to the place of purchase. The manufacturer will, at its option, repair, replace or refund the purchase price to the consumer. All costs of installation and removal of the fixture is the responsibility of the consumer. This warranty does not cover fixtures becoming defective due to misuse, accidental damage or improper handling and/or installation and specifically excludes liability for direct, incidental or consequential damages. As some states do not allow exclusions of limitations on an implied warranty, the above exclusion and limitation may not apply. This warranty gives you specific rights and you may also have other rights which may vary from state to state.