



LED

6" High Output Pro-Optic® LED Wall Washer New Construction Downlight 120-277V 0-10V Dimming

Recessed

Type _____
-EB120V -EB277V

P8223

All Items **MTO**

LED Housing Catalog No. Description

Ceiling Cutout: see guide

P8223-EB120V 6" LED Wall Washer New Construction 120V Housing

Maximum Ceiling Thickness: 1-1/2"

P8223-EB277V 6" LED Wall Washer New Construction 277V Housing

LED Trim

Catalog No.

Reflector Finish

LED Color Temp

P8123 6" Wall Wash, 2800lm module

-21A Clear Alzak®

/30K 3000 Kelvin

-22A Gold Alzak®

/35K 3500 Kelvin

-28 White

/40K 4000 Kelvin

(White flange standard)

Example: P8123-21A/30K (Ordered separately)

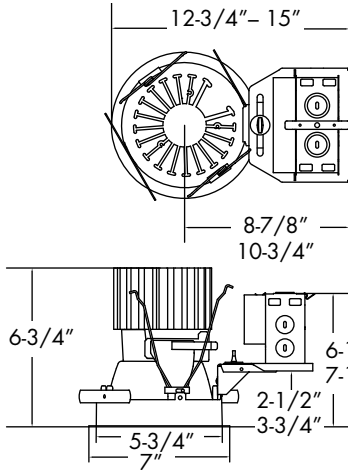

*Dimensions shown are for range of adjustability.

Specifications:

General

- 6" commercial grade LED Wall Wash downlight utilizing remote phosphor technology to obtain color consistency, energy savings, and low maintenance costs
- 50,000 hours minimum life up to 40°C (104° F) in open plenum applications

Module with remote phosphor technology. This technology provides controlled color consistency from fixture to fixture

- The system is designed for optimal life and lumen maintenance (50,000 hours at 70% lumen maintenance)
- Both reflector and light engine assembly are mechanically retained to housing. The light engine comes standard with 80 CRI for all CCT's

Housing

- One-piece 22 gauge non-corrosive steel platform
- Pre-wired J-box with snap-on cover for easy access
- Snap-in connection from driver compartment allows easy installation of light engine/trim assembly without tools above or below the ceiling and can be upgraded to accommodate technology improvements
- Approved for 8 (4 in/4 out) No. 12 AWG conductors rated for 90°C through wiring

LED Driver

- Driver is designed to match the 50,000 hour minimum life expectancy of the system
- Meets UL Class 2, inherent short circuit protection, self limited, overload protected
- Integrated thermal feedback loop will gradually reduce current to protect system life
- Universal driver 120V-277V

Reflector

- High purity aluminum Alzak, iridescence suppressed, semi-diffuse reflector
- Self-flanged trim standard
- White painted self-flanged trim (-28) option available

Dimming

- Flicker-free 0 – 10V dimming to 10%

Labeling

- cCSAus certified to US and Canadian safety standards
- Suitable for wet locations
- 5 year warranty

LED Light Engine

- The P8223 uses the Philips Fortimo DLM LED

Progress Lighting
701 Millennium Blvd.
Greenville, South Carolina
29607

www.progresslighting.com



LED

6" High Output Pro-Optic® LED
Wall Washer New Construction Downlight
P8223/P8123

Recessed

DRIVER DATA	P8123 30K	P8123 35K	P8123 40K	P8123 30K	P8123 35K	P8123 40K
Input Voltage	120V	120V	120V	277V	277V	277V
Input Frequency	60 Hz	60 Hz	60 Hz	60 Hz	60 Hz	60 Hz
Input Current	0.5A	0.5A	0.5A	0.28A	0.28A	0.28A
Input Power	49W	46W	46W	48W	45W	45W
Constant Current Output	.3 – 1.0 A	.3 – 1.0 A	.3 – 1.0 A	.3 – 1.0 A	.3 – 1.0 A	.3 – 1.0 A
Power Factor	≥0.90	≥0.90	≥0.90	≥0.90	≥0.90	≥0.90
THD	<20%	<20%	<20%	<20%	<20%	<20%
EMI Filtering	FCC 47CFR Part15, Class A	FCC 47CFR Part15, Class A	FCC 47CFR Part15, Class A	FCC 47CFR Part15, Class A	FCC 47CFR Part15, Class A	FCC 47CFR Part15, Class A
Operating Temperature	-20°C to 55°C	-20°C to 55°C	20°C to 55°C	-20°C to 55°C	20°C to 55°C	-20°C to 55°C
Dimming	0-10V	0-10V	0-10V	0-10V	0-10V	0-10V

Dimming 0-10V 100% to 10%

Pro-Optic LED driver is compatible with 0-10V type dimming controls. Recommended dimming controls are listed below.

Control Manufacturer	Wallbox Dimmer	Power Booster Available
Douglas Lighting controls	WPC 5721	
Entertainment Technology	Tap Glide TG600FAM120 (120V) Tap Glide Heatsink TGH1500FAM120 (120V) Oasis OA2000FAMU (120/277V)	
Honeywell, Inc.	EL 7315A1019 and EL7315A1009	EL7305A1010
HUNT Dimming	Preset Slide: PS-010-IV-120V and PS-010-WH-120V Preset Slide: PS-010-3W-IV-120V and PS-010-3W-WH-120V Preset Slide: PS-010-IV-277V and PS-010-WH-277V Preset Slide: PS-010-3W-IV-277V and PS-010-3W-WH-277V Preset Slide, controls FD-010: PS-IFC-010-IV- and PS-IFC-010-WH-120/277V Preset Slide, controls FD-010: PS-IFC-010-3W-IV- and PS-IFC-010-3W-WH-120/277V Remoted mounted unit: FD-010-120V and FD-010-277V	
Lehigh Electric Products Co.	Solitaire	PBX
Leviton Lighting Controls Div.	Leviton Centura Fluorescent Control System IllumaTech™ IP7 Series	CN100 PE300
Lutron Electronics Co., Inc.	Visit www.lutron.com/advance for the latest control information and selection	
PDM Electrical products	WPC-5721	
Starfield Controls	TR61 with DALI interface port	RT03 DAL Inet router
The Watt Stopper, Inc.	LS4 used with LCD-101 and LCD-103	

