



Compact Fluorescent

Dynamo

Close-To-Ceiling

Catalog No.	Finish		Lamping	Dimensions (Inches)	
	Brushed Nickel	Antique Bronze		A	B
P3976	-09	-20	4 GU-24 26w	25-7/16	7-1/8

Type _____

-09 -20

P3976

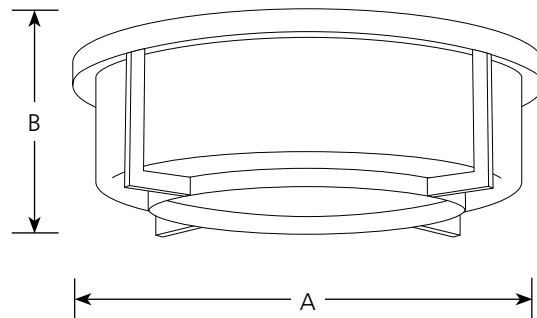

Specifications:

General

- Etched white diffuser: 21-5/8" dia., 5-1/16" ht.
- Plated Brushed Nickel (-09) finish
- Painted Antique Bronze (-20) finish
- Steel construction
- Companion Close-to-ceiling, Pendant, fixtures are available

Electrical

- GU24 base sockets
- Pre-wired

Labeling

- cCSAus Damp location listed

Mounting

- Ceiling flush mount
- Ceiling pancovers a standard 4" hexagonal recessed outlet box
- Mounting strap for outlet box included

Progress Lighting
701 Millennium Blvd.
Greenville, South Carolina
29607

www.progresslighting.com

Rev. 09/13