



Compact Fluorescent

Roman Coach

Outdoor

Energy Star

Type _____
 -09EB -19EB -31EB -33EB
 P5772

Catalog No.	Finish				Lamping	Dimensions (Inches)			
	Brushed Nickel	Roman Bronze	Black	Cobblestone		A	B	C	D
P5772	-09EB	-19EB	-31EB	-33EB	1-26w 4 pin CF	7	26-3/8*	6-7/8	16-1/4

Spiral or triple tube *w/o tail 19-1/4

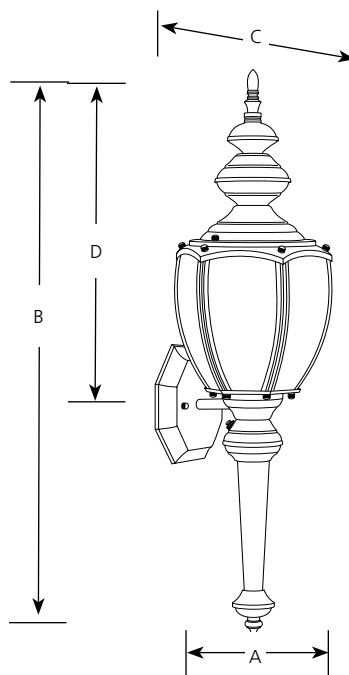

Specifications:

General

- Acorn style
- Solid brass construction
- Plated nickel (-09), or bronze (-19), painted black (-31), or cobblestone (-33) finishes
- Etched white glass curved panels
- Decorative tail supplied with unit. Can be installed with or without tail
- Lamp replacement – remove top of unit
- Energy Star certified
- Matching wall units

Electrical

- GX24q-3 socket
- 120v NPF electronic ballast
- Integral photocell turns unit off during daytime
- Unit will start down to 0 degrees F
- Pre-wired

Labeling

- UL-CUL wet location listed

Mounting

- Wall mounted outdoor.
- Covers standard recessed octagonal outlet box
- Mounting strap for outlet box



Progress Lighting
 701 Millennium Blvd.
 Greenville, South Carolina
 29607

www.progresslighting.com