



Halogen

Calven

Bath & Vanity

Catalog No.	Finish		Lamping	Dimensions (Inches)			
	Brushed Nickel	Forged Black		A	B	C	D
P3210	-09WB	-80WB	2-60w Halogen (G9, 120V) (included)	18-1/8	6-1/8	7-7/8	3
P3223	-09WB	-80WB	3-60w Halogen (G9, 120V) (included)	25-1/8	6-1/8	7-7/8	3
P3236	-09WB	-80WB	4-60w Halogen (G9, 120V) (included)	34-3/8	6-1/2	7-7/8	3-1/4

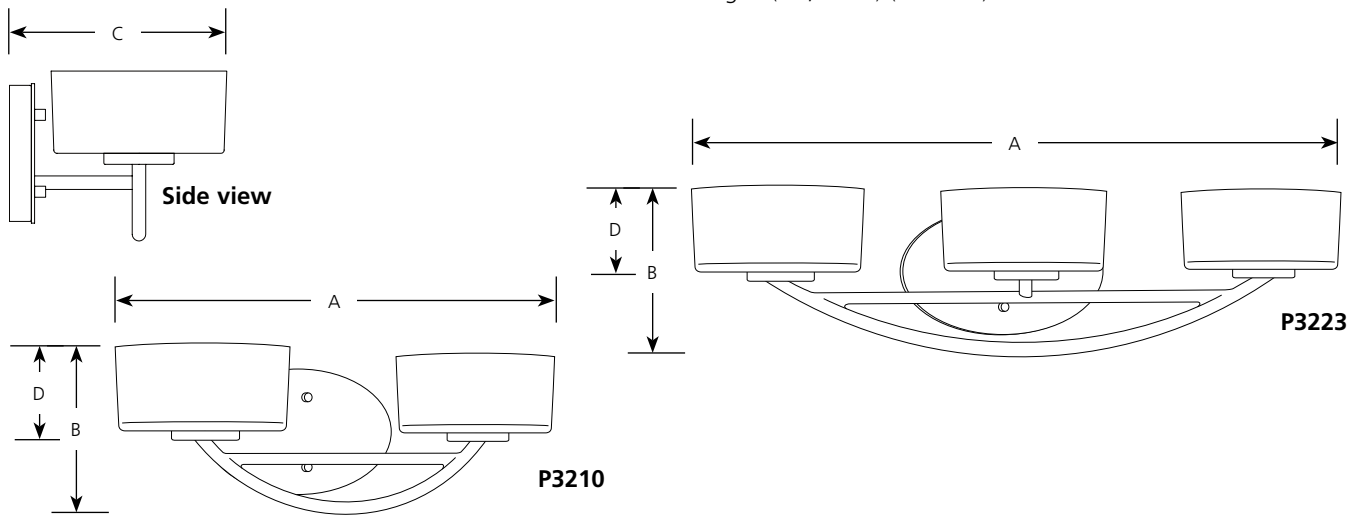

Specifications:

General

- Etched opal glass shades: 6-5/16" dia., 3" ht.
- Clear glass lamp shield
- Plated Brushed Nickel (-09WB) finish
- Painted Forged Black (-80WB) finish
- Steel construction
- Companion Bath and Vanity, Chandelier, Close-to-ceiling, Hall and Foyer, Pendant, Wall bracket, fixtures are available

Mounting

- Wall mount
- Threaded socket ring secures glass
- Mounts in "up" or "down" position
- Back plate covers a standard 4" hexagonal recessed outlet box
P3210, P3223: 8" W., 5" ht.
P3236: 10" W., 5" ht.
- Mounting strap for outlet box included

Electrical

- Pre-wired
- G9 base sockets

Labeling

- cCSAus Damp location listed

Progress Lighting
701 Millennium Blvd.
Greenville, South Carolina
29607

www.progresslighting.com

Rev. 09/13