

PF93511

Sewage Pumps



Product Features

- 1/2 HP cast iron sewage pump
- Submersible sewage pump for typical residential and commercial applications where materials must be moved upward from a basin to sewer or septic lines or to drainage fields
- Comes with 10' power cord
- 7.6 amps, 912 watts
- Maximum head of 25 feet
- Maximum flow rate of 80 GPM
- 2" Solids handling ability
- Permanent split capacitor motor
- 3450 RPM
- Liquid temperature range 32°-120°F
- Discharge Size 2" FNPT
- SJE Rhombus vertical float switch
- Cast iron housing and base
- Cast aluminum, non-clogging vortex impeller



PF93511

Product Specifications

Performance Curve

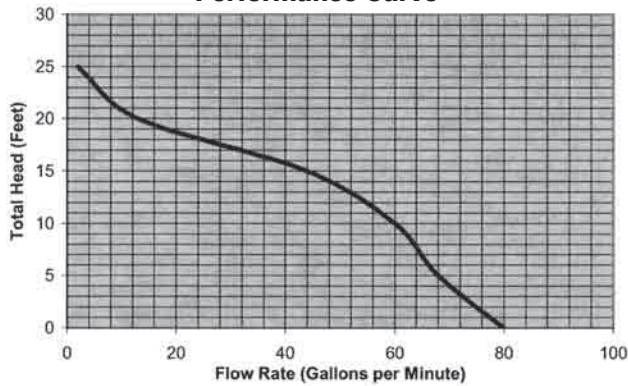

Performance Chart

Discharge Height	0'	5'	10'	15'	20'	25'
Gallons per Minute	80	68	60	44	13	2
Gallons per Hour	4800	4080	3600	2640	780	120

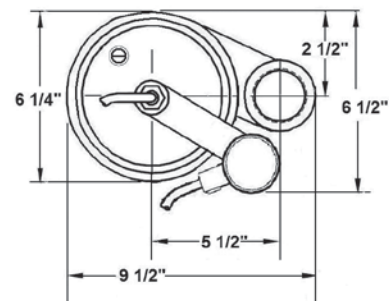
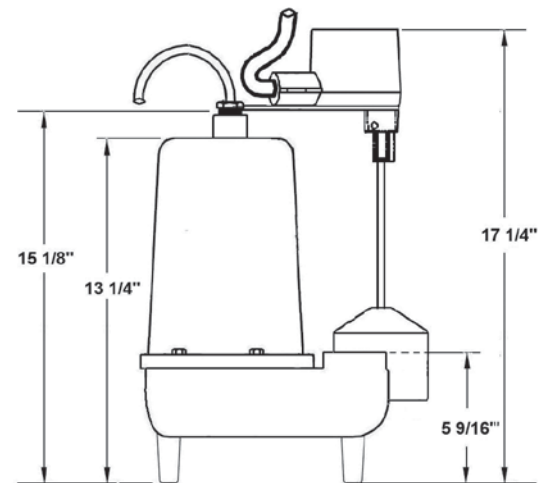

Warranty and Codes

This product comes complete with installation, operating, care and maintenance instructions. This PROFLO pump carries a 3-year limited warranty. In an effort to continually improve our products, we will make design changes from time to time. We reserve the right to ship newly designed products to fill any order unless we agree in writing to do otherwise.

