

PF92910

12 Volt Battery Backup Pump System



Product Features

- 12 Volt DC pump with vertical float switch.
- Electric control panel with indicator lights
- Thermoplastic battery box.
- 87 decibel alarm with mute
- Reverse polarity protection
- Low battery alarm
- Mounting hardware included.
- Maximum flow rate 23 gpm.
- 1-1/4" or 1-1/2" NPT discharge size.
- Handles 1/8" solids.
- AC charger
- Full flow check valve.
- Battery sold separately.



PF92910

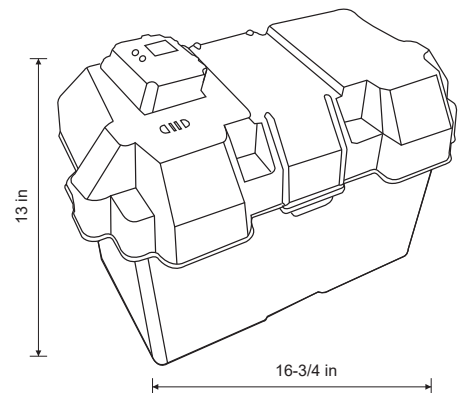
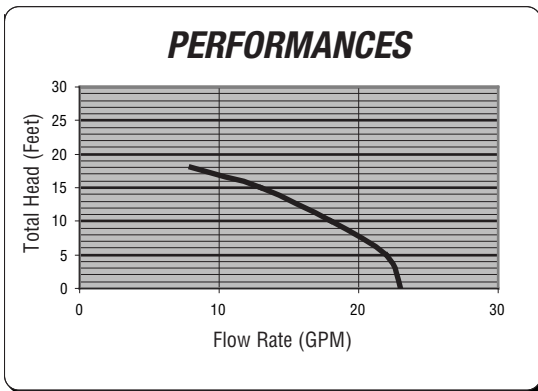

Discharge Height	0'	5'	10'	15'	20'
Gallons per Minute	23	22	18	13	8
Gallons per Hour	1380	1320	1080	780	480

Warranty and Codes

These products come complete with installation, operating, care and maintenance instructions. This PROFLO product carries a 3-year limited warranty. In an effort to continually improve our products, FEI will make design changes from time to time. We reserve the right to ship newly designed product to fill any order unless we agree in writing to do otherwise.

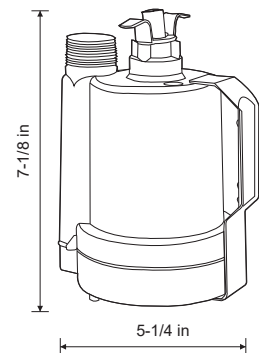

Construction

- Thermoplastic housing and base
- Thermoplastic impeller