

Specifications

PFUC209RBA UNDERMOUNT STAINLESS STEEL DOUBLE BOWL SINK



Product Features

- 18 gauge stainless steel
- Overall size: 32" x 18-1/2"
- Bowl size: 13-3/16" x 16-1/2"
- Bowl depth: 9"
- Drain deameter: 3-1/2"
- Under spray coating and pads for sound deadening and insulation
- Double bowl sink
- cUPC/IAPMO listed
- Sink clips and cutout template included



PFUC209RBA

Product Specifications

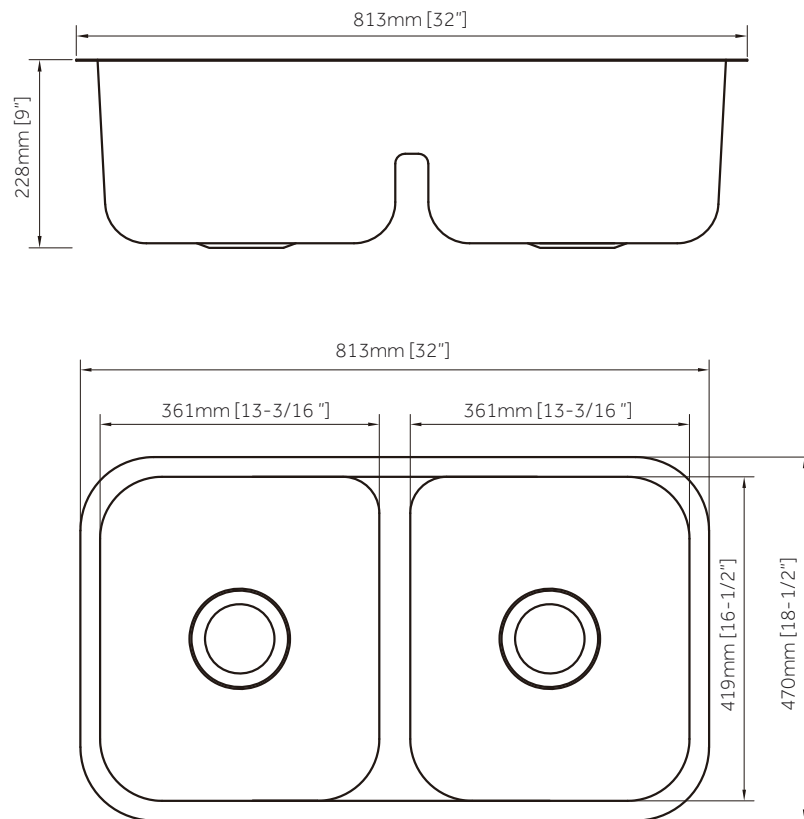

* All measurements are nominal. Please verify before actual installation.

Warranty and Codes

This PROFLO product carries a limited lifetime warranty in residential applications. Warranty is 5 years in commercial applications. This product comes complete with installation, operating, care and maintenance instructions. This product meets ASME/ANSI: A112.19.3M .

