



PF91665 Descaler Pump Kit

Product Description

The PROFLO Descaler Pump Kit is designed to remove scale, lime, mineral deposits and rust from tankless water heaters. Regular descaling will improve heat transfer and efficiency.

Product Features

- Energy efficient 55 watt mag drive pump
- 3.5 Gallon pail with screw top lid for easy access & storage
- Two - 6' clear poly hoses allow debris to be seen while pumping
- Bucket filter grate to protect pump from larger debris

Mag Drive Pump Features

- Continuous duty 55 watt motor
- Thermoplastic construction
- Fully submersible
- Thermoplastic impeller
- Built-in adjustable control valve to control flow
- 3/4" Garden hose adapter included
- Screen removes easily for cleaning
- Acceptable for indoor or outdoor use
- Compact, lightweight design is easily portable
- 25' power cord

Mag Drive Performance

- 55 Watt 120 Volt AC (.45 amps)

| Performance Chart | | | | | | |
|-------------------|------|------|-----|-----|-----|----|
| Lift | 0' | 2' | 4' | 6' | 8' | 9' |
| GPM | 13.5 | 11.5 | 9 | 6 | 3 | 1 |
| GPH | 810 | 690 | 540 | 360 | 180 | 60 |

Warranty and Codes

This product comes complete with installation, operating, care and maintenance instructions. This PROFLO descaler pump kit carries a 1 year warranty when installed in residential applications. See owners manual for warranty details.

This PROFLO descaler pump kit carries a 1 year limited warranty. In an effort to continually improve our products, we will make design changes from time to time. We reserve the right to ship newly designed product to fill any order unless it is agreed in writing to do otherwise.



PF91665

Product Specifications

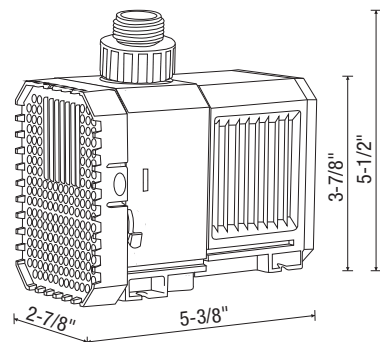
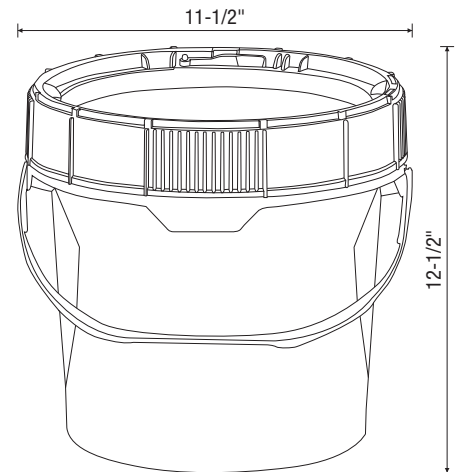

* All measurements are nominal. Please verify before actual installation.