

PF93020

Simplex Sewage Pump Kit



Pump Features

- 1/2 HP Cast Iron Sewage Pump (PF93511)
- 2" Discharge
- Handles 2" spherical solids
- Vertical Float Switch
- Non-clogging vortex impeller
- Will handle temperatures up to 120° F
- Stainless steel fasteners
- UL listed

Basin Features

- Structural foam construction
- Corrosion resistant
- 18" x 30" - 30 gallon capacity
- Premium structural foam cover with 8 bolt configuration
- Air tight, molded, reuseable PVC seal
- Pre-plumbed with 2" PVC pipe, 30" long
- 4" Inlet with Snap-In-Hub
- 2" Discharge & Vent

Pre-plumbed system includes:

- 1/2 HP Cast Iron Sewage Pump (PF93511)
- 18" x 30" Structural foam basin with cover
- 2" x 30" of PVC pipe

Warranty and Codes

This product comes complete with installation, operating, care and maintenance instructions. This PROFLO pump carries a 3-year limited warranty. In an effort to continually improve our products, we will make design changes from time to time. We reserve the right to ship newly designed products to fill any order unless we agree in writing to do otherwise.



PF93020

Product Specifications

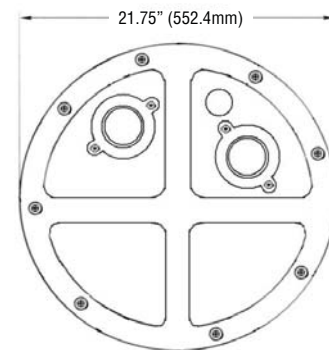
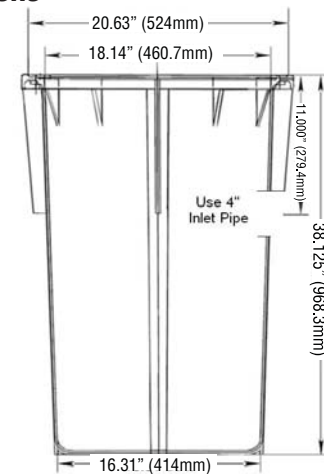

* All measurements are nominal. Please verify before actual installation.

