

# PF93015

## Simplex Sewage Pump Kit



### Pump Features

- 1/2 HP cast iron sewage pump (PF93501)
- 2" Discharge
- Handles 2" spherical solids
- Wide angle float switch
- Non-clogging vortex impeller
- Will handle temperatures up to 120° F
- Stainless steel fasteners
- UL listed

### Basin Features

- Structural foam construction
- Corrosion resistant
- 18"x30" - 30 gallon capacity
- Premium structural foam cover with 8 bolt configuration
- Air tight, molded, reusable PVC seal
- Pre-plumbed with 2" PVC pipe, 30" long
- 4" Inlet with hub
- 2" Discharge and vent

### Pre-plumbed system includes:

- 1/2 HP cast iron sewage pump (PF93501)
- 18" x 30" Structural foam basin with cover
- 2" x 30" of PVC pipe



### Warranty and Codes

This product comes complete with installation, operating, care and maintenance instructions. This PROFLO pump carries a 3-year limited warranty. In an effort to continually improve our products, we will make design changes from time to time. We reserve the right to ship newly designed products to fill any order unless we agree in writing to do otherwise.



PF93015

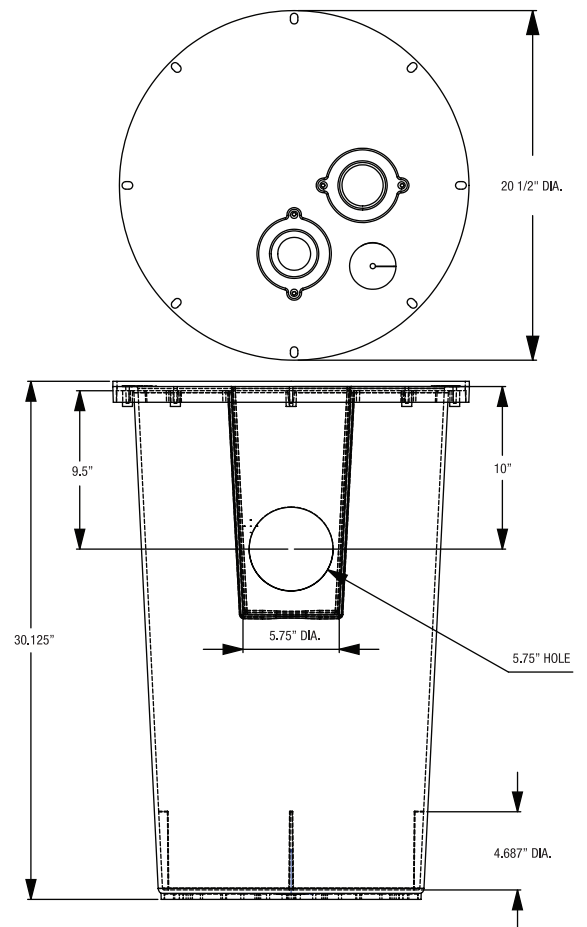

\* All measurements are nominal. Please verify before actual installation.