

PF92017

Remote Sink/Drain Pump Kit



Pump Features

- 1/3 HP cast iron pump with vertical float switch
- 1-1/2" Discharge
- Handles 3/8" solids
- Passes laundry lint
- Non-clogging impeller
- Will handle temperatures up to 120° F
- Pumps up to 46 GPM
- Stainless steel fasteners
- 10' Power cord
- UL listed

Basin Features

- Structural foam construction
- Corrosion resistant
- 15" x 13-1/2" - 6 gallon capacity
- Gasket Sealed, Air Tight Cover with 8 bolts
- 1-1/2" Inlet, discharge & vent



PF92017

Check Valve Features

- 1-1/2" x 1-1/4" PVC Flapper check valve (PFCVJH)
- Stainless steel clamps
- ABS body

Pre-assembled system includes:

- 1/3 HP cast iron sump pump (PF92341)
- 15" x 13 1/2" structural foam basin with cover
- 1-1/2" check valve (PFCVJH)
- Pre-assembled with an 8" length of PVC pipe. Just connect drain, discharge and vent pipe.

Product Specifications

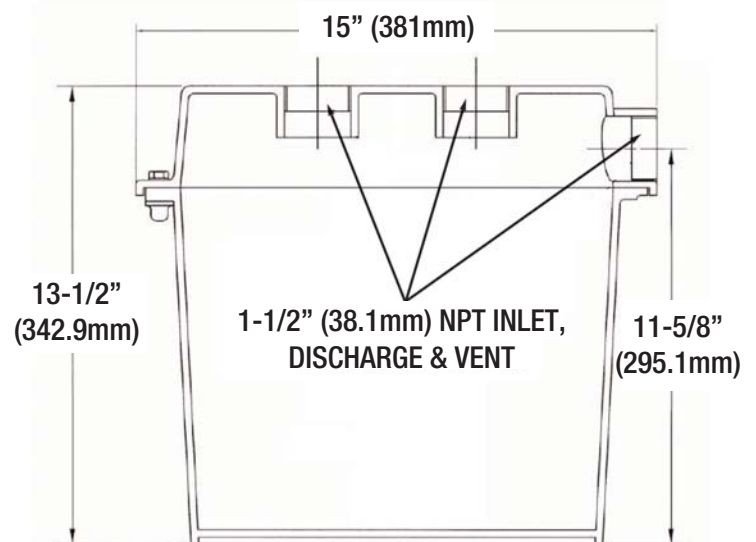

* All measurements are nominal. Please verify before actual installation.
DO NOT USE WITH AN AUTOMATIC AIR ADMITTANCE VALVE.

Warranty and Codes

This product comes complete with installation, operating, care and maintenance instructions. This PROFLO pump carries a 5-year limited warranty. In an effort to continually improve our products, we will make design changes from time to time. We reserve the right to ship newly designed products to fill any order unless we agree in writing to do otherwise.

