



Design & Specification Package

Thank you for considering PITT® Cooking. PITT® Cooking cooktops are handmade in Holland and are beautifully integrated directly into your countertop.

PITT® Cooking are specialists in integrated cooking and our mission is to offer you the perfect combination of functionality and design. To guaranty a safe & proper installation of PITT® Cooking, we ask that you forward this document onto any trade professionals that may be involved in your project, including your trade professionals listed below:

- Architect
- Kitchen Designer
- Kitchen Company
- General Contractor/Builder
- Cabinet Maker
- Fabricator/Stonemason
- Plumber/Installer

If there are any questions about the above information, please feel free to contact us. Our website, www.pittcookingamerica.com, has lots of detailed instructions for designers and installers.

Regards,

PITT Cooking America
e: info@pittcookingamerica.com
p: (720) 924-9948
w: www.pittcookingamerica.com

We would like to summarize the most important points of interest for your PITT Cooking installation:

1. Design of Cabinetry

Make sure that the module can always be accessed, in the case of service, and the PITT® Cooking module should always be able to be disassembled without disassembling the cabinets and/or kitchen benchtop.

This means that you should use the Construction Checklist if you want to place the module above a center partition. Please see page 16 for more information

2. Support Beams

The PITT® Cooking module should always be fully supported to prevent any flexing of the kitchen benchtop.

The countertop where the PITT unit is installed should have full support on the left, right, front and back in the kitchen countertop. This prevents tension in the countertop from the weight of the PITT cooking module. Please refer to the section “Instructions for installation of support set” on page 13.

3. Hole Cutouts in Countertop

The inside of the cutouts should be smooth and even.

Our recommendation is that your fabricator should apply on the top and bottom of the cutouts a facet of at least 1x1 mm.

4. Gas Pressure Regulator Installation

Included separately in your PITT Cooking unit package is a gas pressure regulator. It is critical that the pressure regulator be installed to the manifold pipe using pipe-joint compound (resistant to LP and Natural gas) on threads of manifold pipe. To prevent possible damage to the gas pressure regulator, please install it after the appliance is in its permanent position. See page 15 for instructions.

5. Natural Gas to Propane Conversion

The PITT Cooktop can work on either natural gas or propane. All PITT Cooktops are shipped to be used with natural gas. See the specific instructions on page 19 to convert your PITT Cooktop from natural gas to propane.

In the following pages you will find these documents:

- Specification File
- Benchtop and Cabinetry procedures and guidelines
- Installation and handling instructions
- Support Bar Installation
- Construction Checklist
- Natural Gas to Propane Conversion
- Maintenance advice
- Technical measurements

Benchtop and Cabinetry procedures and guidelines for PITT® cooking

**For more detailed information visit Installation
and handling instructions www.pittcooking.info**

Caution

**Do not use the enclosed Aluminum Heat
Conductor as a benchtop template! Only
use the paper template provided.**

**Do not forget to install the Gas Pressure
Regulator once the PITT Cooktop has
been installed into the countertop.**

1. *Benchtop material suitable for PITT® cooking*

1a. The following worktop materials are allowed to use in combination with PITT® cooking:

- Quartz composite (eg. Caesarstone, Silestone, Quantum Quartz, Smartstone)
- Natural stone (eg. granite, marble)
- Glass
- Concrete
- Compact board (eg. Trespa)
- Ceramics (eg. Dekton, Neolith, Maximim)
- Terrazzo
- Stainless steel (eg. 4 mm solid or 1(+) mm on substrate board*



PITT® cooking should never be installed into solid wood or benchtops with an HPL top layer. (eg. Laminex)

1b. The minimum thickness of the core material is 4 mm.

For Quartz composite, compact board and natural stone applies a minimum thickness of the core material (solid) of 10 mm.

For Top Side for all materials, a maximum thickness of 35 mm applies.

For Front Side for all materials, a maximum thickness of 25 mm applies.



The bottom of the benchtop needs to be completely flat, in order to bring the heat conductor in full contact with the benchtop.

* When using a stainless steel benchtop with a substrate a suitable adhesive must be used. The min specifications for the adhesive is 90 degrees Celsius

2. Manufacturing hole cut-outs for benchtop's



The guidelines of the kitchen manufacturer and/or the manufacturer of the kitchen benchtop should always be strictly followed.

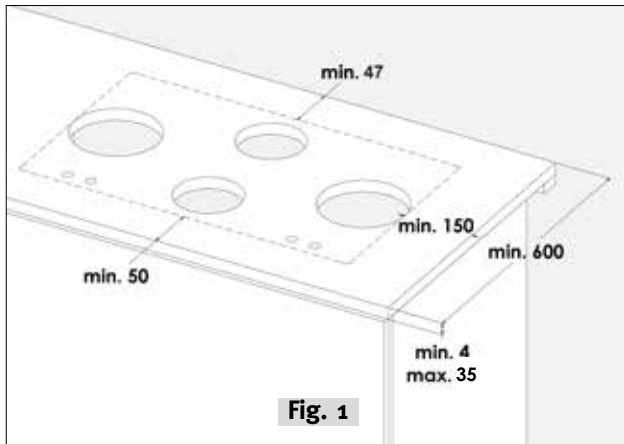

- 2a. The C-size for Top Side models should be at least 50 mm (fig.1). The distance between the cut out (Top Side and Front Side) and the sides (left or right) of the benchtop should be at least 150 mm.

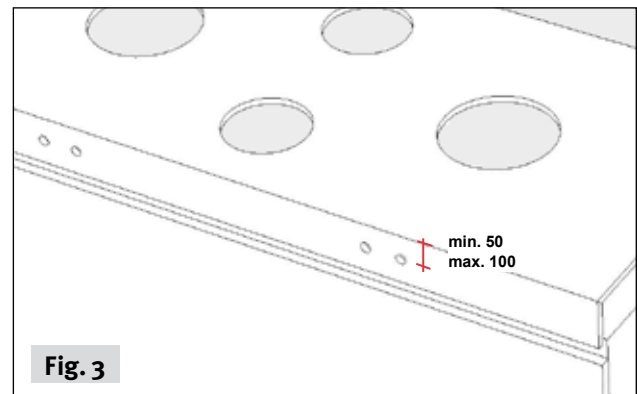
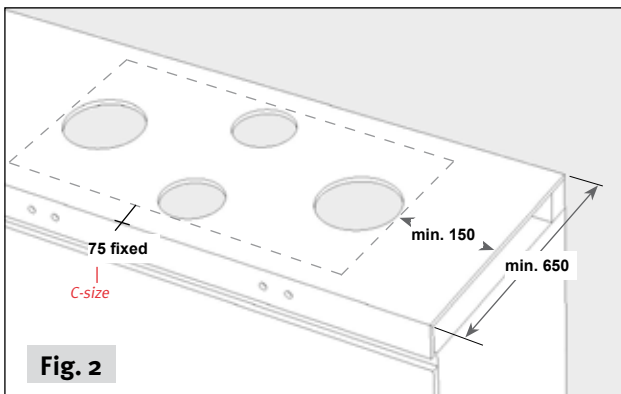

- 2b. The C-size for Front Side models should be **at all times 75 mm (fig.2)**

Front Side can be applied to the front side of the work top as well as the blind of the kitchen cabinet (whether indented or not). The center of the knobs measured from the top of the benchtop is at least 50 and at most 100 mm (fig.3).

2. Manufacturing hole cut-outs

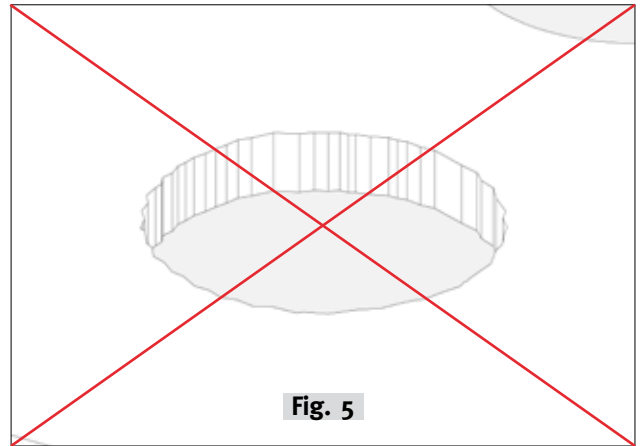
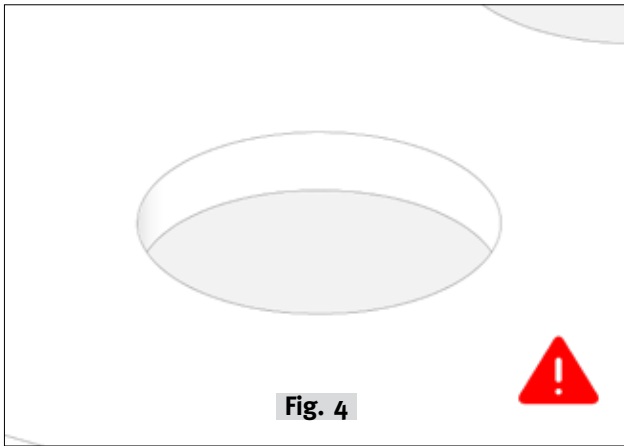

- 2c. The insides of the holes should be smooth and even (**fig. 4**). Irregularities can cause cracking (**fig. 5**).

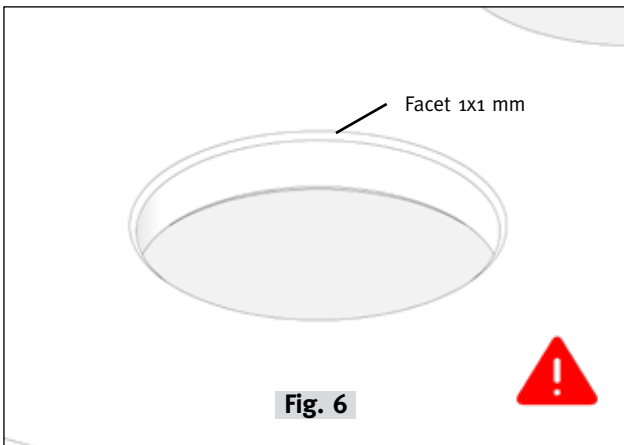

- 2d. On the top and bottom of the holes should be a facet of at least 1x1 mm be applied (**fig. 6**).

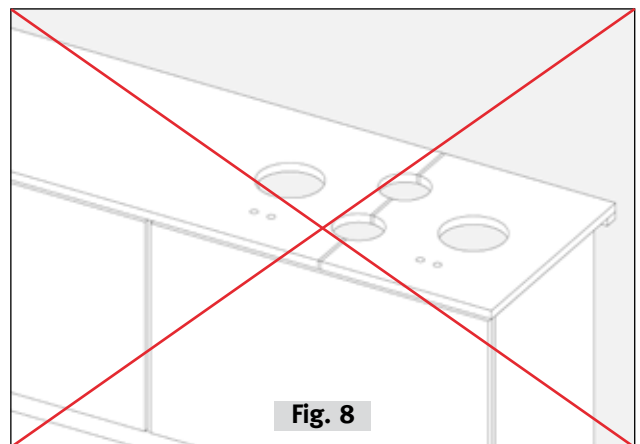
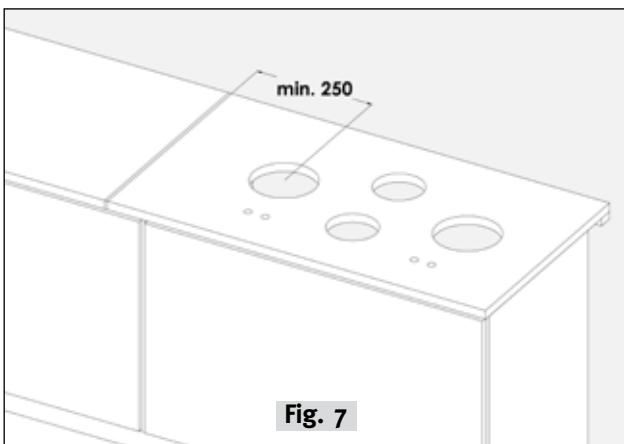

- 2e. Adhesive connections and/or interconnections should **never** intersect the holes. These should have a distance of at least 250 mm to center of the hole (**fig. 7 and 8**).

2. Manufacturing hole cut-outs

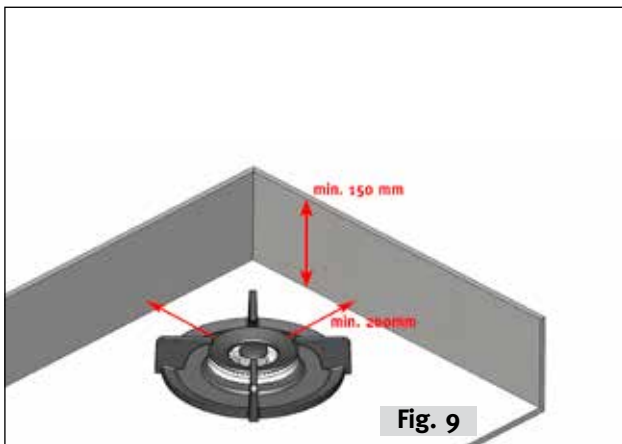

- 2f.** The minimum clearance from a combustible surface shall be a 200 mm horizontal distance from the periphery of any gas burner (AS/NZS 5601.1). **(fig. 9).**

If that horizontal clearance is less than 200 mm, that vertical surface must be protected by a non-combustible material for 150 mm above the cooktop surface across the entire length (depth, width).

3. Installation the kitchen benchtop



The guidelines of the kitchen manufacturer and/or the manufacturer of the kitchen benchtop should always be strictly followed.

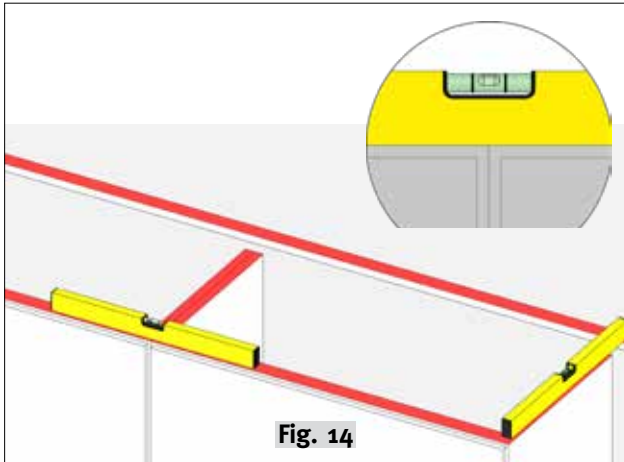

Fig. 14

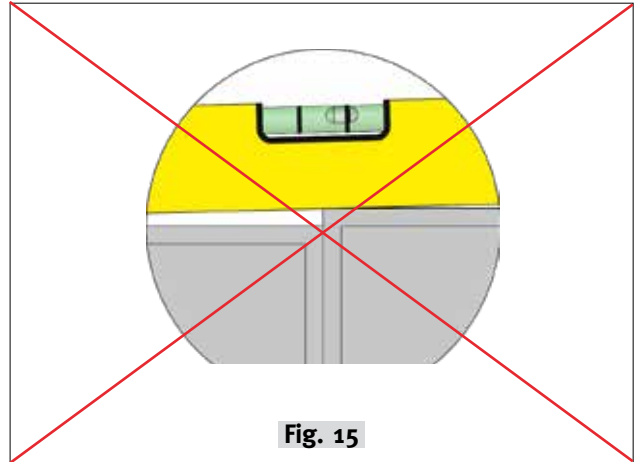

Fig. 15

- 3a. The cabinets should be placed perfectly levelled (fig. 14 and 15).

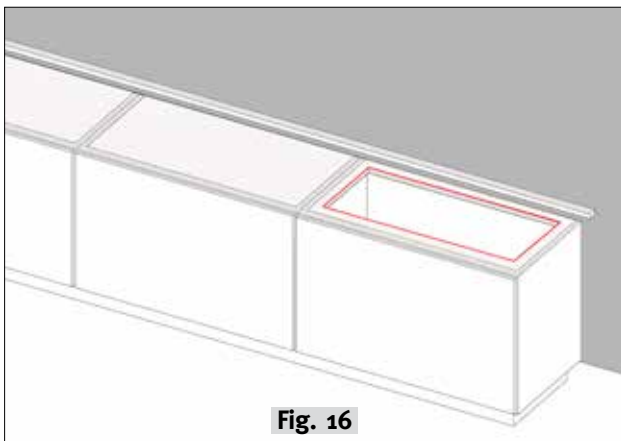
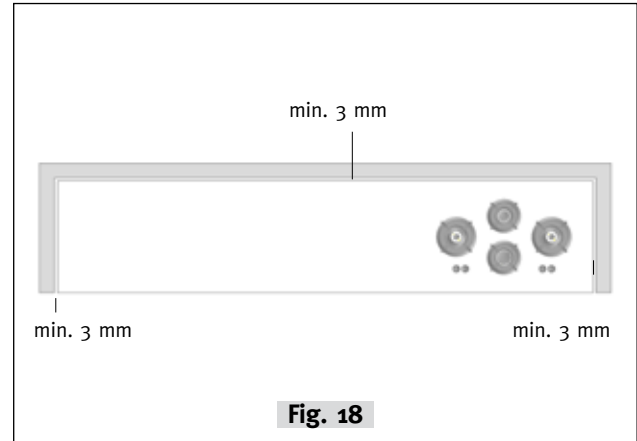
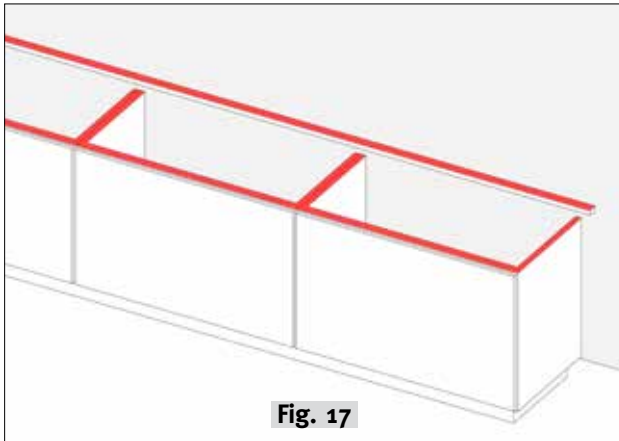

Fig. 16

- 3b. If there is a substrate under the benchtop the substrate should be cut to fit the PIT cooktop. The cutout should be the same size (+10 mm) as the PITT® cooking module. This is to bring the heat conductor in full contact with the core material (fig. 16).

3. Installation the kitchen benchtop



- 3c.** The benchtop should have full support on the left, right, front and back side of the PITT cooking unit (**fig. 17**). This prevents tension in the benchtop from the weight of the cooking unit. We advise to support the benchtop with a ladder frame.
- 3d.** The distance between the kitchen benchtop and the wall and/or cabinets should be at least 3 mm (**fig. 18**). This allows the material to expand.

4. Installation PITT® cooking into benchtop



Strictly follow the PITT® cooking installation instructions. The installation manual can be downloaded via www.pittcooking.com/downloads.

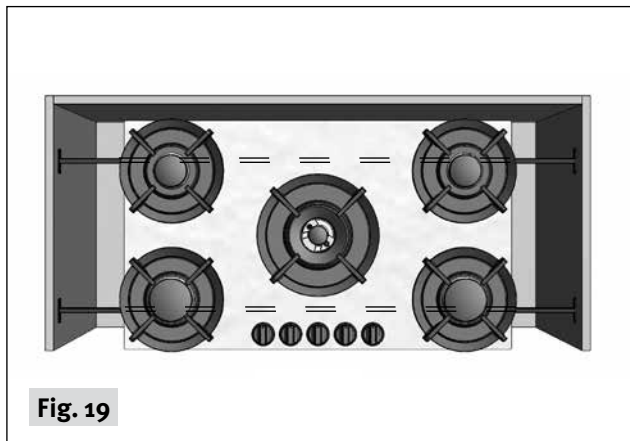

Fig. 19

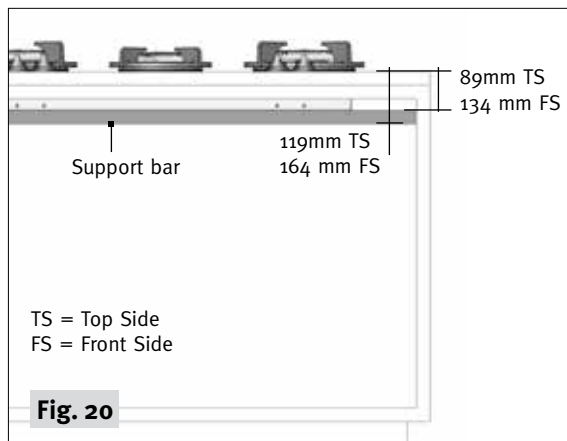

Fig. 20

- 4a. The PITT® cooking module should always be fully supported with the PITT® cooking support set to prevent bending of the kitchen benchtop (**fig. 19 and 20**).

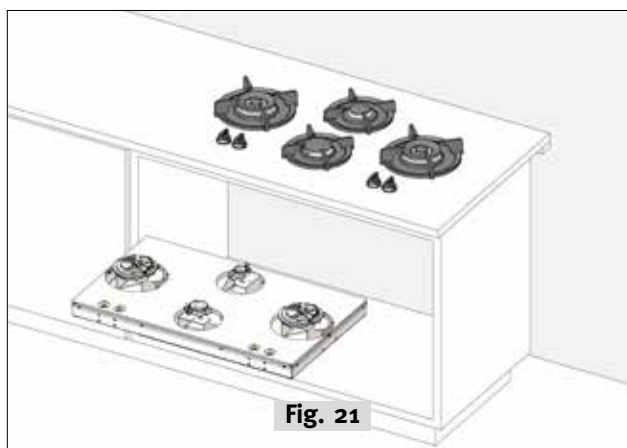

Fig. 21

- 4b. In case of service, the PITT® cooking module should **ALWAYS** be able to be disassembled without disassembling the cabinets and/or kitchen benchtop (**fig. 21**).

Follow these instructions to install your PITT Cooking cooktop into your countertop. Once the cooktop is installed with support bars, **DO NOT FORGET** to install the included Gas Pressure Regulator.

See page 15 for instructions on how to install the Gas Pressure Regulator.

Please visit this [VIDEO LINK](#) for a detailed video with tips and tricks on your PITT Cooking cooktop installation.

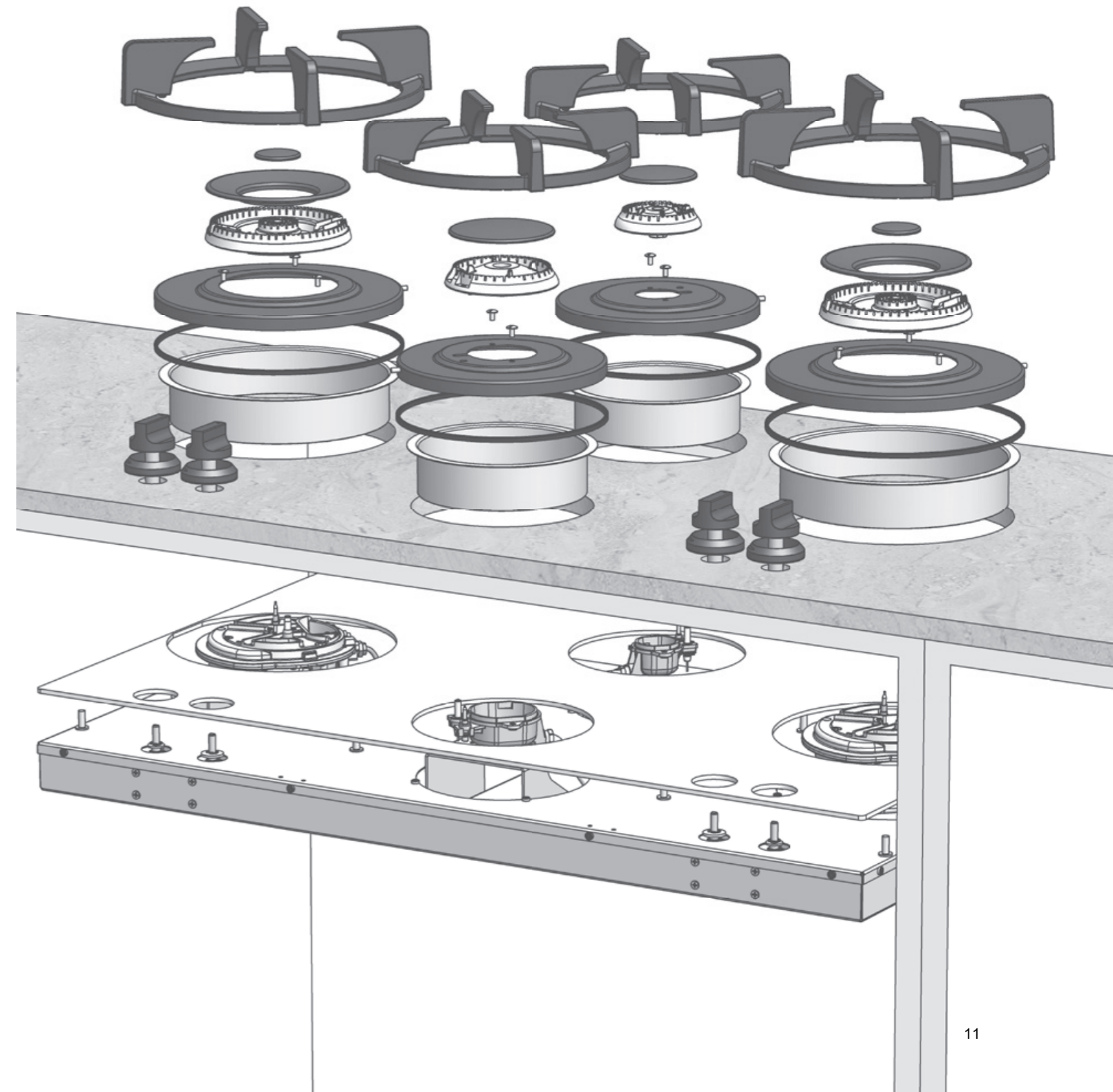

Installation instructions

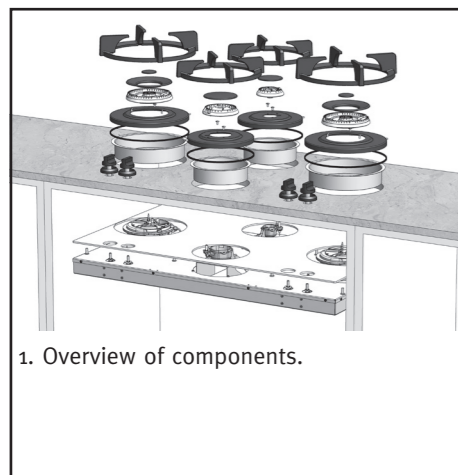

1. Overview of components.

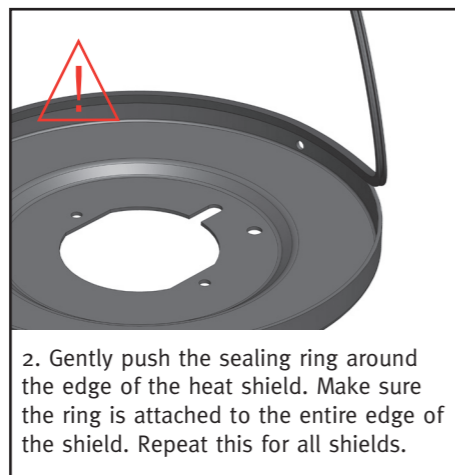

2. Gently push the sealing ring around the edge of the heat shield. Make sure the ring is attached to the entire edge of the shield. Repeat this for all shields.

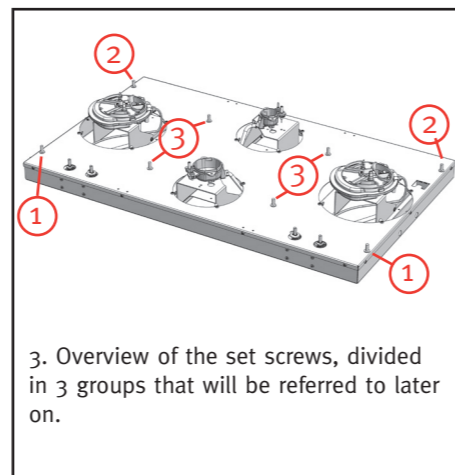

3. Overview of the set screws, divided in 3 groups that will be referred to later on.



10. Do not separate the protective film from the adhesive strip for the next steps!

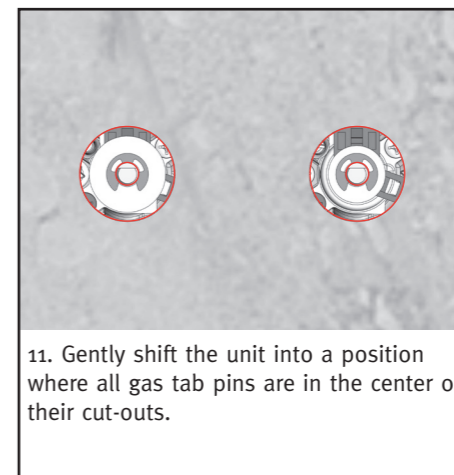

11. Gently shift the unit into a position where all gas tab pins are in the center of their cut-outs.

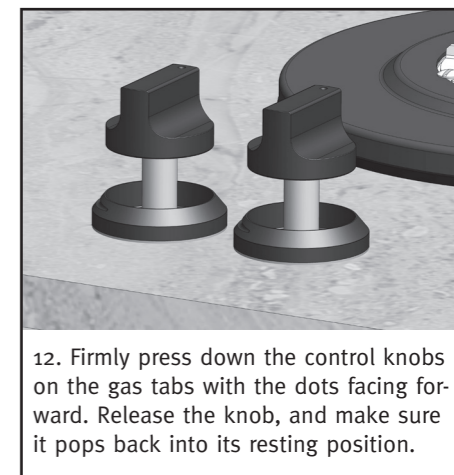

12. Firmly press down the control knobs on the gas tabs with the dots facing forward. Release the knob, and make sure it pops back into its resting position.

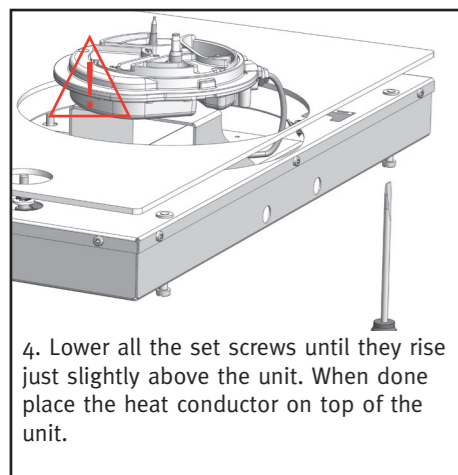

4. Lower all the set screws until they rise just slightly above the unit. When done place the heat conductor on top of the unit.

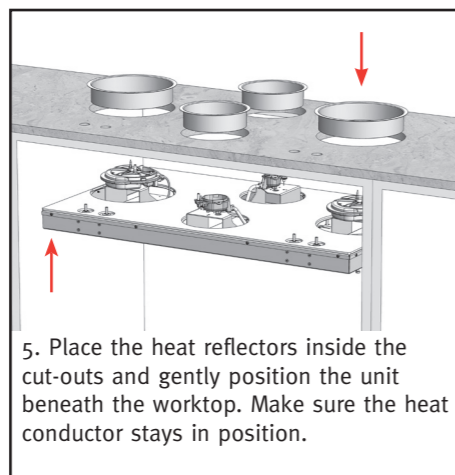

5. Place the heat reflectors inside the cut-outs and gently position the unit beneath the worktop. Make sure the heat conductor stays in position.

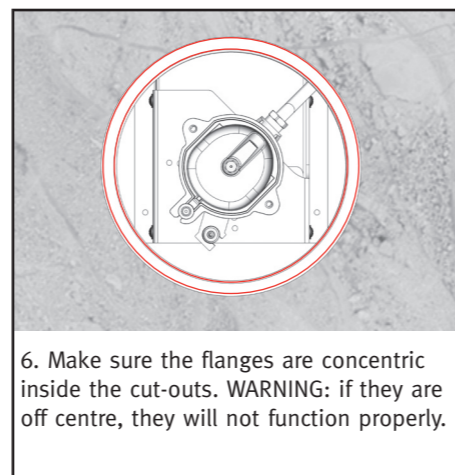

6. Make sure the flanges are concentric inside the cut-outs. **WARNING:** if they are off centre, they will not function properly.

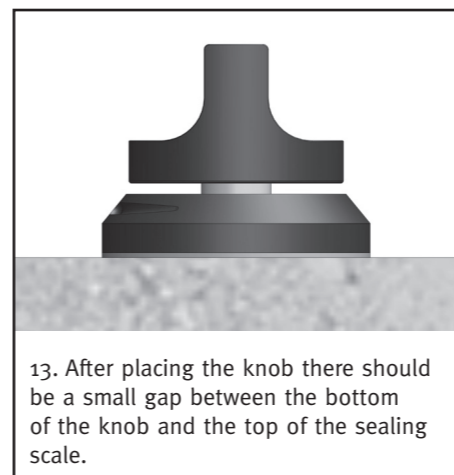

13. After placing the knob there should be a small gap between the bottom of the knob and the top of the sealing scale.

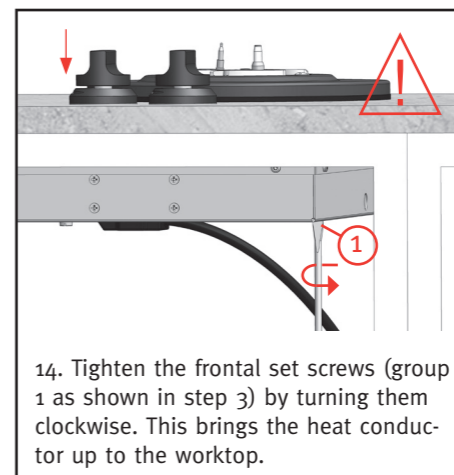

14. Tighten the frontal set screws (group 1 as shown in step 3) by turning them clockwise. This brings the heat conductor up to the worktop.

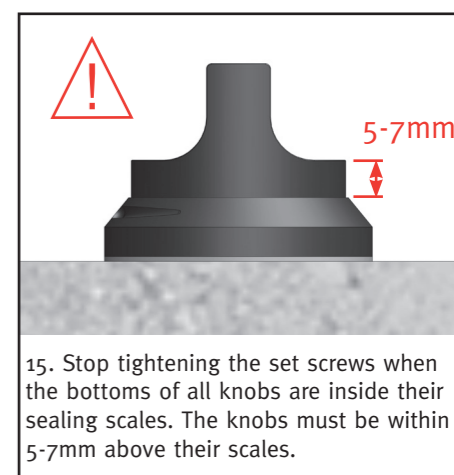

15. Stop tightening the set screws when the bottoms of all knobs are inside their sealing scales. The knobs must be within 5-7mm above their scales.

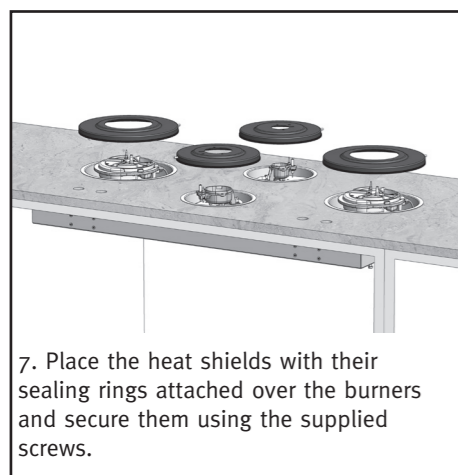

7. Place the heat shields with their sealing rings attached over the burners and secure them using the supplied screws.

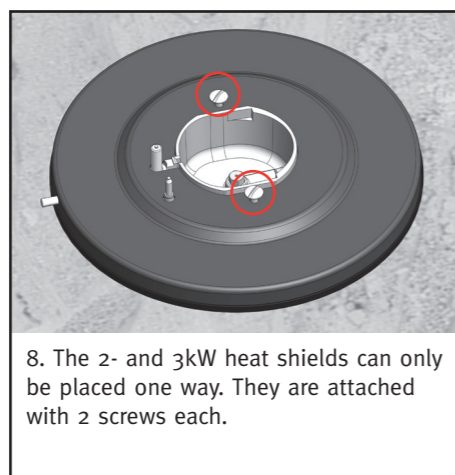

8. The 2- and 3kW heat shields can only be placed one way. They are attached with 2 screws each.

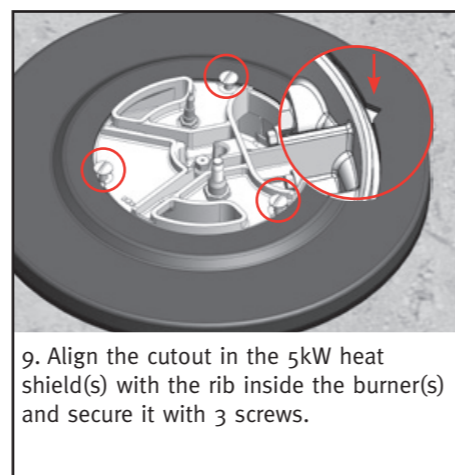

9. Align the cutout in the 5kW heat shield(s) with the rib inside the burner(s) and secure it with 3 screws.

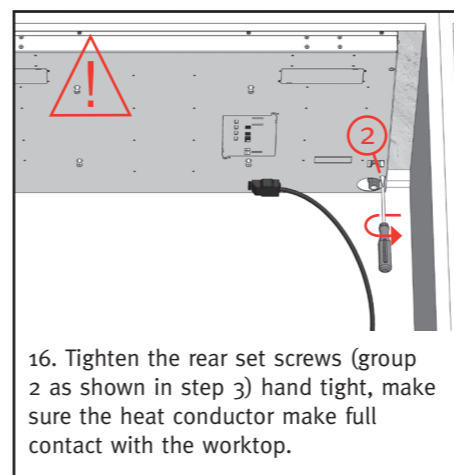

16. Tighten the rear set screws (group 2 as shown in step 3) hand tight, make sure the heat conductor makes full contact with the worktop.

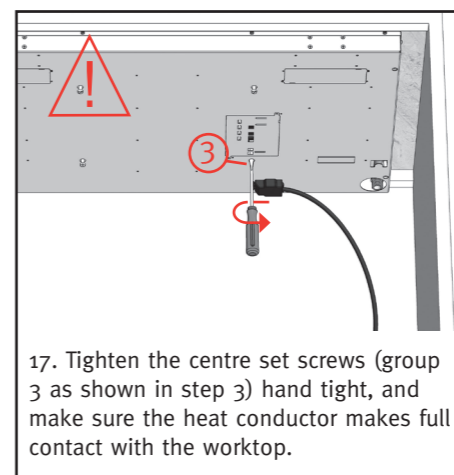

17. Tighten the centre set screws (group 3 as shown in step 3) hand tight, and make sure the heat conductor makes full contact with the worktop.

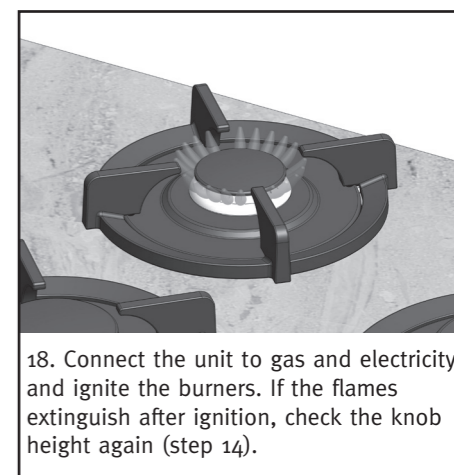

18. Connect the unit to gas and electricity and ignite the burners. If the flames extinguish after ignition, check the knob height again (step 14).



Important!

When the control knobs are not properly adjusted, the burners will not ignite or burn evenly.

For warranty and a proper functioning of the cooking unit, ensure to exactly follow all steps as described in this installation manual.

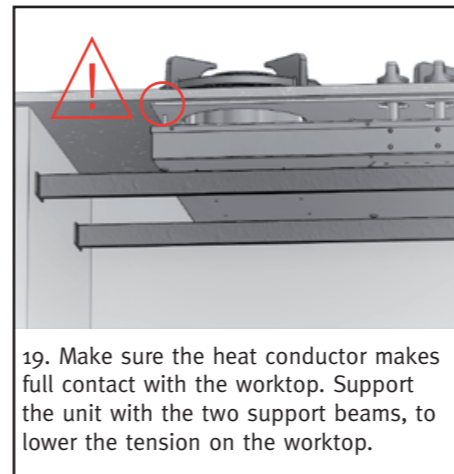

19. Make sure the heat conductor makes full contact with the worktop. Support the unit with the two support beams, to lower the tension on the worktop.

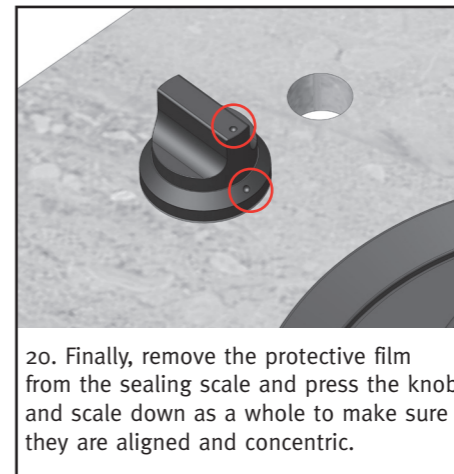

20. Finally, remove the protective film from the sealing scale and press the knob and scale down as a whole to make sure they are aligned and concentric.

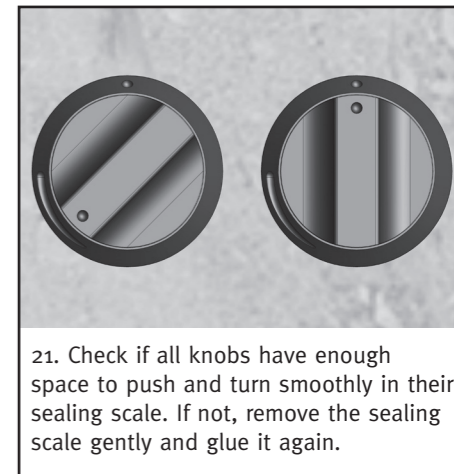

21. Check if all knobs have enough space to push and turn smoothly in their sealing scale. If not, remove the sealing scale gently and glue it again.

Contents of package:

2x support beams



4x inserts



16x cross-point screws 4,2x16 mm



Tools needed:

- Measuring tape
- Cross-point screwdriver
- Metallic saw

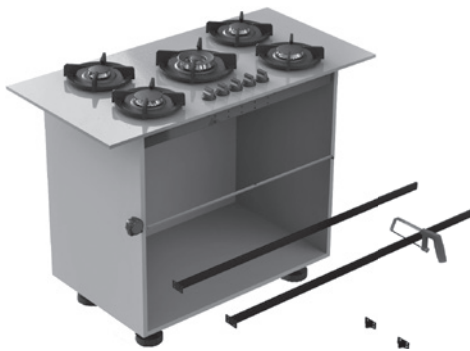

1. Determine the dimensions of the cabinet and cut the support beams with the saw. **ATTENTION!** Correct length of the beam = the dimension of cabinet on the inside - 4 mm.

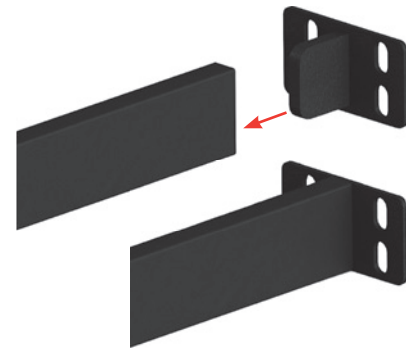

2. Place the inserts into the ends of the beams that have been cut to size.

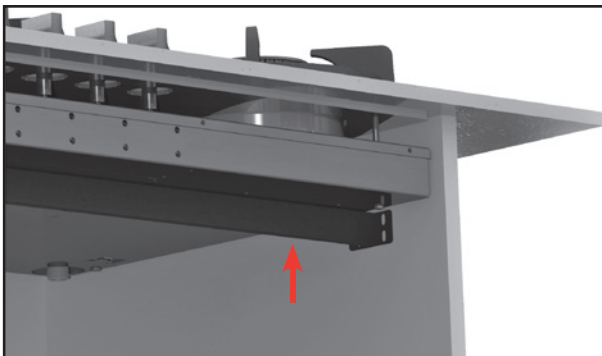

3. Place the beams between the cabinet and position it against the under side of the PITT® cooking unit. **ATTENTION: FOR THE POSITIONING, SEE STEP 4.**

* Minimum distance of 80 mm

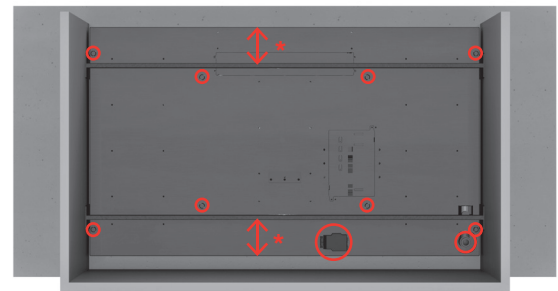

4. Position the beams in such a way that the screws, gas connection and the electricity block are freely accessible.

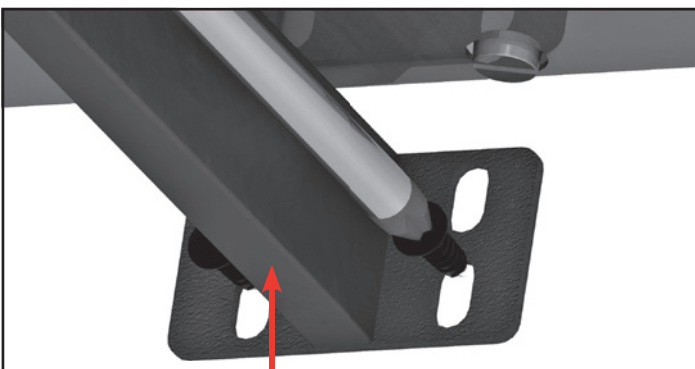

5. Push the beams firmly against the underside of the PITT® cooking unit and tighten the lower two screws by hand. Repeat this step for the other side of the cabinet.

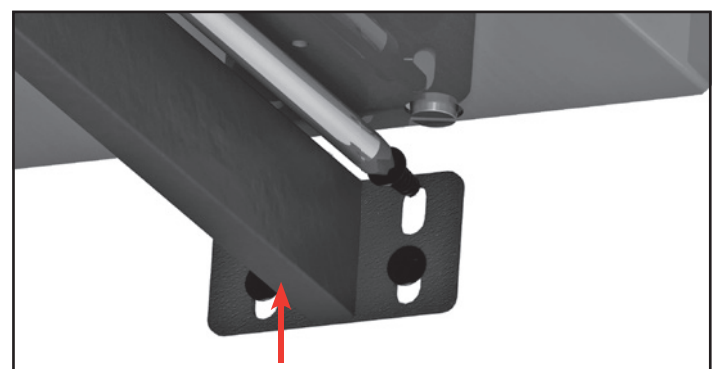

6. Push the beams firmly against the underside of the PITT® cooking unit and tighten the upper two screws completely. Then, tighten the lower screws completely.

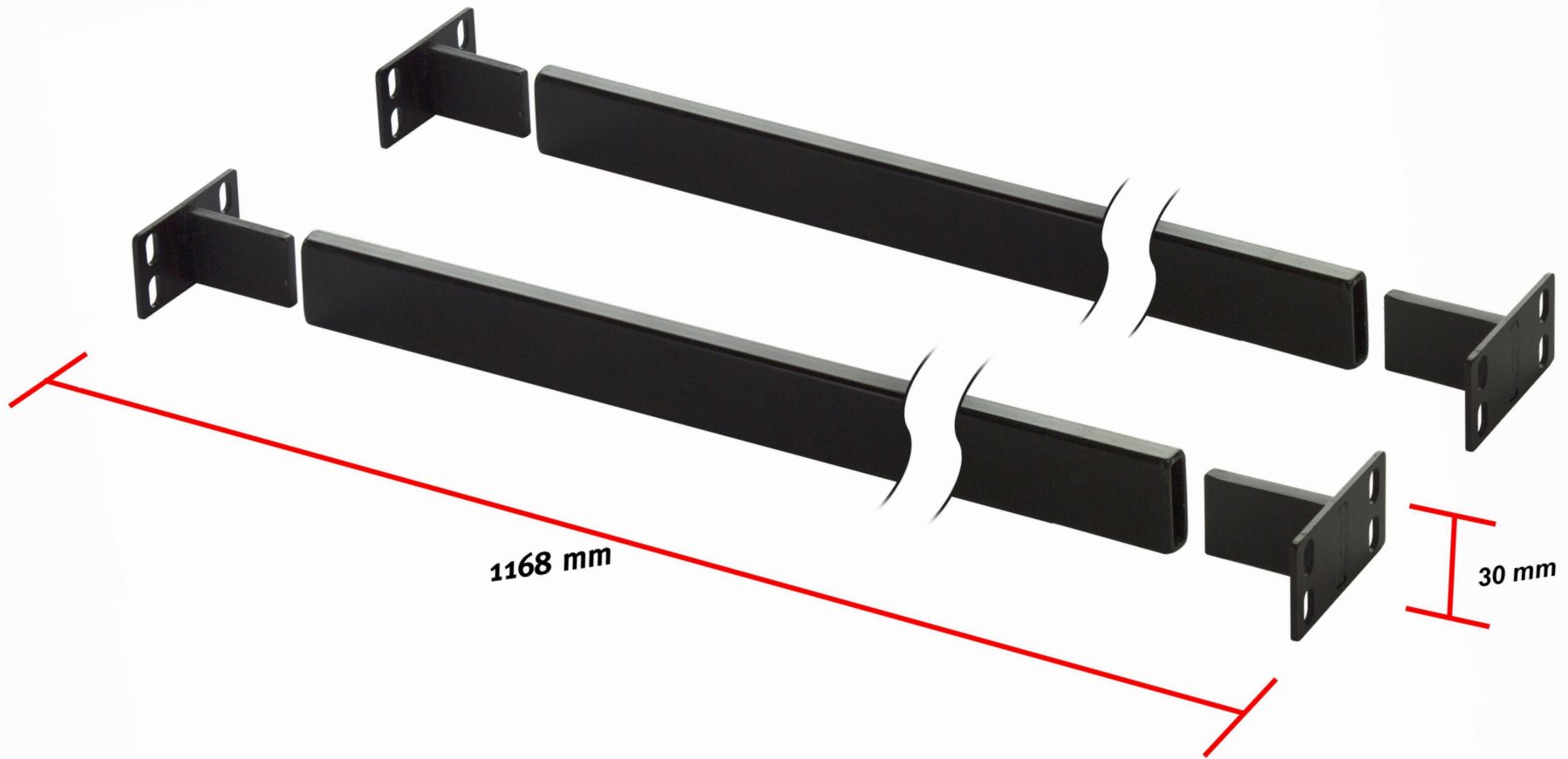

1168 mm

30 mm

2 Connection: gas and electrical

Gas connection instructions

- Check that installation or local distribution regulations (type of gas and gas pressure) match the setting value of this device.
- The setting values of this device are indicated on the type plate.
- This device is not equipped with a combustion gas drain installation. Installation and connection must comply with the regulations in force locally and nationwide. You must check the regulations in regards to ventilation requirements.
- The gas connection must comply with the general regulations. We recommend to connect the hob with a fixed gas pipeline or to use an approved gas hose.
- Install the pressure regulator (fig 4a) (supplied with unit) to manifold pipe using pipe-joint compound (resistant to LP and Natural gas) on threads of manifold pipe. Turn to hand tighten plus 1/4 turn, not exceeding 1 turn for alignment. To prevent possible damage to the gas pressure regulator, install it after the appliance is in its permanent position. When the regulator is securely installed on the manifold pipe, the conversion nut will be easily accessible.
- Always use a full metal hose behind the oven.
- An approved gas hose should not be kinked and should not come into contact with moving parts of the kitchen furniture.
- The main gas supply must be in an easily accessible place.
- Before using the cooking unit check all the connections for leaks with a soap solution.

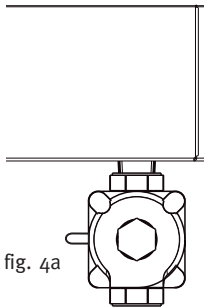

Caution: Do not attempt any adjustment of the pressure regulator, except conversion to propane.

Electrical connection instructions*

120 V – 60 Hz – 0,6 VA

- The electrical installation must conform to the national and local regulations.
- Power socket and plug must always be reachable.
- Connect the unit with the supplied plug to an earthed socket.
- Damage to the connection cable may only be replaced by the manufacturer, or an approved Installer. This to prevent dangerous situations.







Battery spark ignition*

1,5V DC

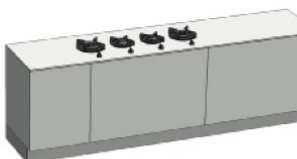

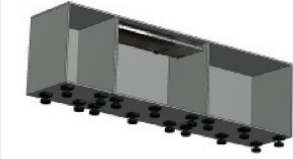
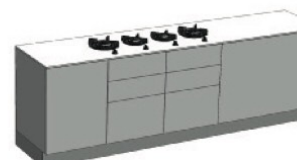
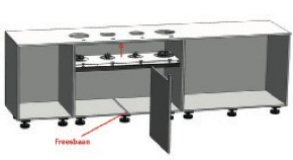
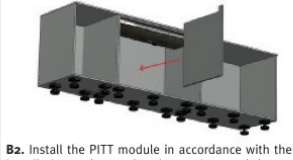
- The spark ignition operates through a battery AA.
- The battery is positioned in the casing at the underside.
- Replace the battery if the spark ignition does not operate

* Depending on the model

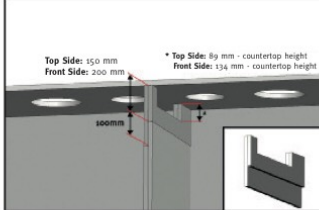
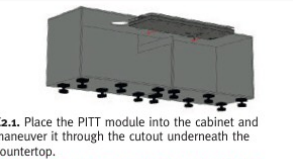
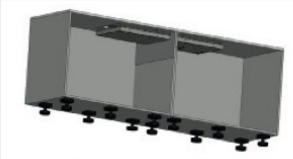
Construction: checklist

 <p>Option A: 1 cabinet</p>	 <p>A1. Position the PITT module in the cabinet.</p>	 <p>A2. Install the PITT module in accordance with the installation and procedure instructions.</p>
 <p>Option B: 2 cabinets</p>	 <p>B1. Remove the center wall of the cabinet and place the PITT module into the cabinet.</p>	 <p>B2. Install the PITT module in accordance with the installation and procedure instructions and then slide the center wall back in by way of a routed groove.</p>
 <p>Option C: 2 cabinets</p>	 <p>C1. Place two individual PITT modules into the two cabinets.</p>	 <p>C1.2. Install the two PITT modules in accordance with the installation and procedure instructions.</p>
 <p>C2.1. Place the PITT module into the cabinet and maneuver it through the cutout underneath the countertop. CAUTION! Pay close attention to the height of the cutouts: min. 150 mm Top Side/200 mm Front Side from the bottom of the countertop!</p>	 <p>C2.2. Install the PITT module in accordance with the installation and procedure instructions and place the divider.</p>	 <p>C2.3. Install the PITT support bars in accordance with the instructions.</p>

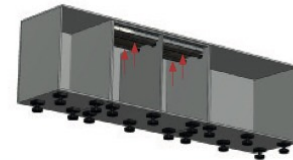
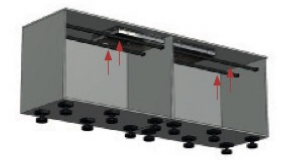
Construction: checklist

 <p>A3. Install the PITT cooking pair of support bars in accordance with the instructions.</p>	<p>Option A: The module is installed within the breadth of one single cabinet. Pay attention to the proper positioning of the pair of support bars.</p>
 <p>B3. Install the two pairs of PITT cooking support bars in accordance with the instructions.</p>	<p>Option B: The module is installed over the junction of two cabinets. Provide for a removable divider via a routed groove.</p>
 <p>C1.3. Install the two pairs of PITT cooking support bars in accordance with the instructions.</p>	<p>Option C1: The module is installed over the junction of two cabinets. Combine two individual PITT modules each of which fits within the breadth of a single cabinet.</p>
 <p>C2.3. Install the PITT support bars in accordance with the instructions.</p>	<p>Option C2: The module is installed over the junction of two cabinets. Provide a removable divider that complies with the correct minimum heights.</p>

1. Material / Design

- Is the material of the worktop suitable?
- Does the original thickness of the worktop fit the requirements?
- Does the PITT unit fit according to the depth of the worktop?
- Is the required minimum C-size being applied?
- Does the minimum required C-size fit into the design?
(Taken into account, for example: grip rails, constructions cabinet/front)?
- Is the distance from side to first cut-out at least 150 mm on both sides?
- Does the entire width of the PITT unit fit into the width of the cabinet?
- Can the PITT unit be freely disassembled without disassembling the cabinets/worktop?
- In case of a cutlery tray: does the height of the unit still fit?

2. Cut-outs

- Are all regulations from both PITT and worktop manufacturer about the making of the cut-outs known? Is every cut-out smooth and even?
- Is a facet of at least 1×1 mm applied on top and bottom of the recess(es)?

3. Installation

See next page.

For more information, check:

1. The PITT Portal Knowledge Base & File Manager, via pitt-portal.com
2. Document: 'Installation and handling instructions PITT cooking'
3. Document: PITT cooking Installation manual

3. Installation

- Do the knobs run smoothly in the scale?
If not: reposition the scale. See Installation manual step 20-21.

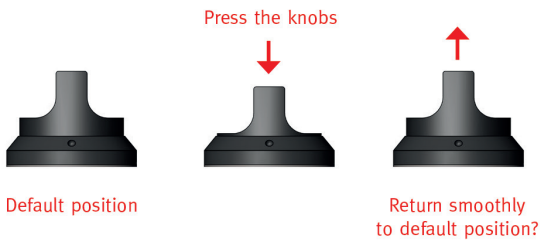

- Do the knobs have the right height?
If not: re-adjust the height. See Installation manual step 13-18.

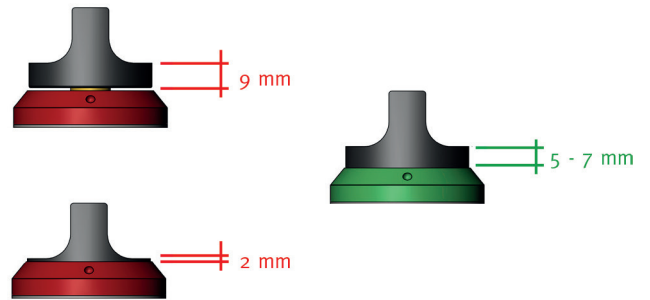

- Are the knobs centered in the cut-out?
If not: re-adjust the appliance. See Installation manual step 6-18.



- Are the knobs standing straight?
If not: re-adjust the appliance. See Installation manual step 6-18.

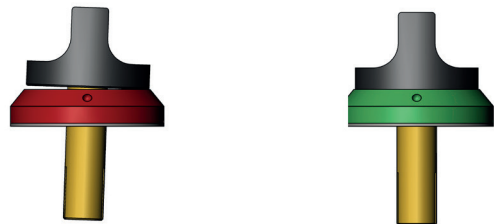

- Does the heat conductor make proper contact with the worktop?
If not: adjust the screws of heat conductor in right order. See Installation manual step 14-17.

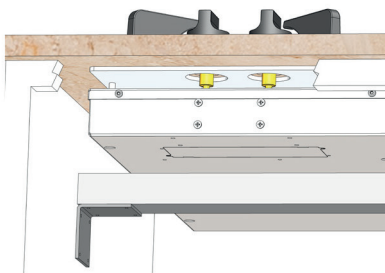

- Is the support bar* properly positioned?
In case of a cabinet width of 900 mm or more, the module should always be fully supported.

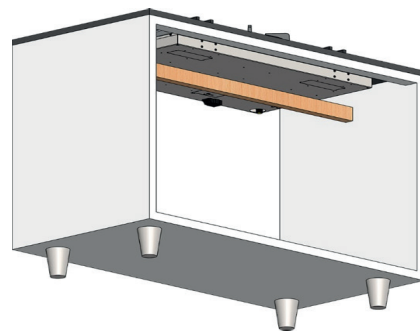

***Profile of support bar**
Length depends on size of cabinet

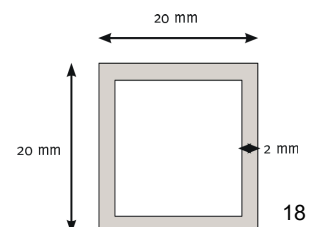

Natural Gas to Propane Conversion

There are 3 steps to convert our PITT Cooktops from Natural Gas to Propane

Step 1 – Convert the Gas Pressure Regulator from Natural Gas to Propane (Called 'Universal LPG' in the below instructions)

PITT

Instructions to convert the regulator from Natural gas to Universal LPG

NOTE!!

If changes are made, a new type of sticker has to be applied over the existing sticker on the underside of the hot plate.

The installation and assembly shall be undertaken by an authorised installer.



Remove the cap from the top of the regulator



Remove the plastic shaft from the cap by pushing it sideways until it pops out of the groove in the cap. Turn the shaft over and push back into the cut-out in the cap.



Replace the cap on the regulator.

Step 2 – Replace the Natural Gas Orifices (aka Nozzles in the charts below) with Propane Orifices found in the Propane Conversion Pack

PITT

Instructions for replacing nozzles

Note! !

Only the burner valves for the 2 and 3 kW burners need to be reset when the nozzles are being replaced. These are recognisable by the extra recess next to the burner valve.

If there is no change in the gas type, but the pressure changes (e.g. G20-20 mbar to G20-13 mbar), then only the nozzles need to be replaced.

If changes are made, a new type of sticker has to be applied over the existing sticker on the underside of the hot plate.

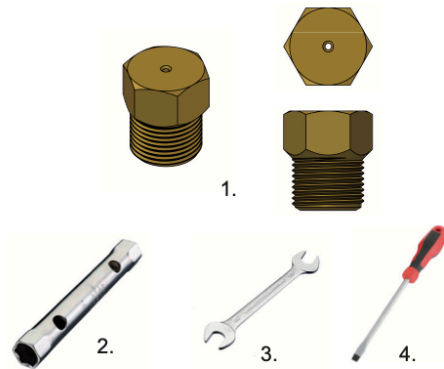

Required parts/tools: nozzles (1), box spanner 7 mm (2) open-ended spanner 7 mm (3), flat-blade screwdriver (4).

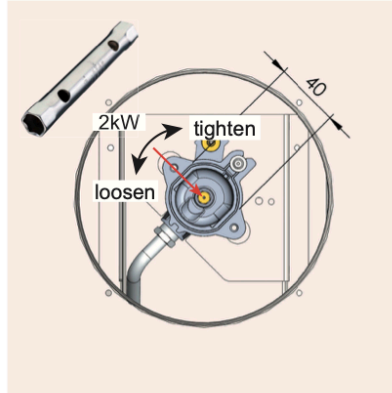
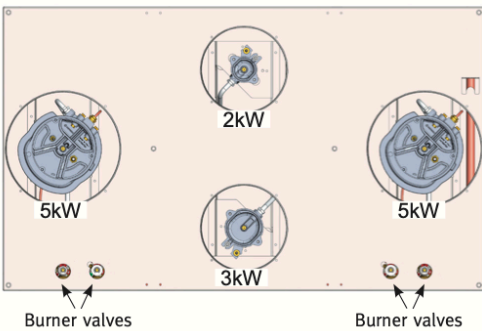

Replace nozzle 2 kW. Loosen the existing nozzle (anti-clockwise). Tighten the new nozzle (clockwise).

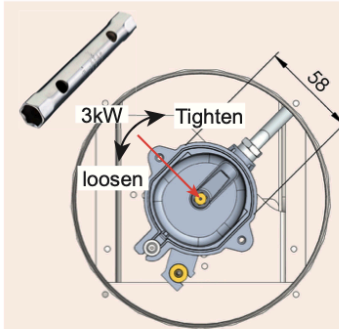

Replace nozzle 3 kW. Loosen the existing nozzle (anti-clockwise). Tighten the new nozzle (clockwise).

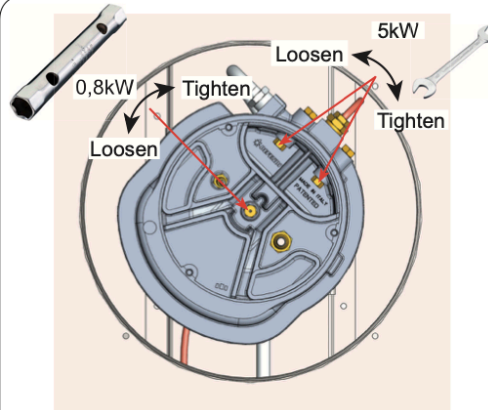

Replace nozzle 0.8 and 5 kW. Loosen the existing nozzle (anti-clockwise). Tighten the new nozzle (clockwise).

Step 3 – Reset the burner valves for the 2kW and 3kW burners, located next to the knobs. Please note that only the 2kW and 3kW have an exposed burner valve adjustment screw (as seen in the images below)

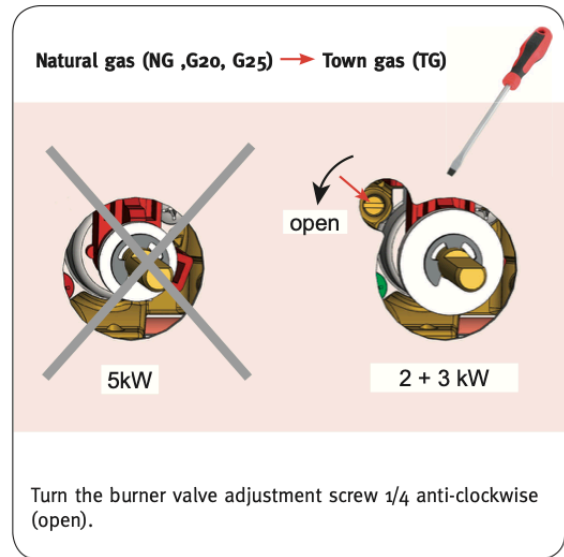
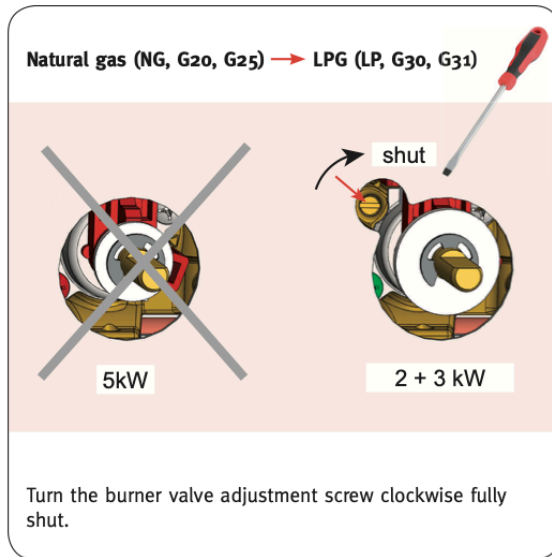

1.

Burner caps and pan supports

We recommend that dirty burner caps and pan supports be soaked for about an hour in a liquid soap and baking soda mixture before being rubbed with a cloth or soft sponge. The silver-colored scratches that sometimes appear on the pan supports are caused by the base of your pan(s). Higher-grade pans definitely have a softer base and the material can sometimes rub off. With the rough side of a (scouring) sponge you can remove this.

Aluminium burners

Aluminium burners can be left to soak in cleaning vinegar overnight and then cleaned with a sponge and a little soap. Note: the aluminium parts must not be cleaned with baking soda as this can attack the aluminium.

Please note: The various components of the burners are not suitable for cleaning in a dishwasher. The open structure of the cast iron can cause soap residue to remain in the material, resulting in a dull appearance.



LINKS TO PRODUCT TECHNICAL SPECIFICATIONS (Hole Patterns & Technical Measurements)

Single Burners

[Akan TOP SIDE KNOBS](#)

[Akan FRONT SIDE KNOBS](#)

[Altar TOP SIDE KNOBS](#)

[Altar FRONT SIDE KNOBS](#)

[Azuma TOP SIDE KNOBS](#)

[Azuma FRONT SIDE KNOBS](#)

[Air TOP SIDE KNOBS](#)

[Air FRONT SIDE KNOBS](#)

Two Burners

[Baluran TOP SIDE KNOBS](#)

[Baluran FRONT SIDE KNOBS](#)

[Bennet TOP SIDE KNOBS](#)

[Bennet FRONT SIDE KNOBS](#)

[Baula TOP SIDE KNOBS](#)

[Baula FRONT SIDE KNOBS](#)

[Bely TOP SIDE KNOBS](#)

[Bely FRONT SIDE KNOBS](#)

[Bromo TOP SIDE KNOBS](#)

[Bromo FRONT SIDE KNOBS](#)

Three Burners

[Cima TOP SIDE KNOBS](#)

[Cima FRONT SIDE KNOBS](#)

[Capital TOP SIDE KNOBS](#)

[Capital FRONT SIDE KNOBS](#)

[Cusin TOP SIDE KNOBS](#)

[Cusin FRONT SIDE KNOBS](#)

[Colo TOP SIDE KNOBS](#)

[Colo FRONT SIDE KNOBS](#)

Four Burners

[Danau TOP SIDE KNOBS](#)

[Danau FRONT SIDE KNOBS](#)

[Drum TOP SIDE KNOBS](#)

[Drum FRONT SIDE KNOBS](#)

[Dempo TOP SIDE KNOBS](#)

[Dempo FRONT SIDE KNOBS](#)

Five Burners

[Elbrus TOP SIDE KNOBS](#)

[Elbrus FRONT SIDE KNOBS](#)

[Ebeko TOP SIDE KNOBS](#)

[Ebeko FRONT SIDE KNOBS](#)

[Enep TOP SIDE KNOBS](#)

[Enep FRONT SIDE KNOBS](#)

Six Burners

[Foessa TOP SIDE KNOBS](#)

[Foessa FRONT SIDE KNOBS](#)