

Installation Support • Soporte de instalación • Support d'installation

Personal Assistance, Product Specs, Installation Videos & "How-to" Questions:

Asistencia personal, especificaciones de productos, videos de instalación y de "cómo hacerlo" preguntas:

Aide personnelle, spécifications du produit, vidéos d'installation et "comment faire" questions:



1-800-PFAUCET
(732-8238)



pfisterfaucets.com/universal



Watch. Learn. Install.
Mira. Aprende. Instalar.
Regarder. En savoir. Installer.

⚠ WARNING / ADVERTENCIA / AVERTISSEMENT

To reduce the risk of injury or property damage, read all instructions before installing product. Wear safety goggles. Product must be installed in accordance with all state & local plumbing & building codes. Call a professional if you are uncertain about installing this product.

This product has been designed for use with the Pfister™, Moen, and Delta in-wall valves. It will not work with any other product valve. Please review complete installation instructions before installing this product.

Para disminuir el riesgo de lesiones o daños a la propiedad, lea todas las instrucciones antes de instalar el producto. Utilice gafas de seguridad. El producto deberá instalarse de acuerdo con la normativa de plomería y construcción estatal y local. Llame a un profesional si no está seguro sobre cómo instalar este producto. Este producto ha sido diseñado para su uso con el Pfister, Moen, y Delta en la pared válvulas. No va a funcionar con cualquier otro producto de la válvula. Por favor revise las instrucciones completas de instalación antes de instalar este producto.

Pour réduire le risque de blessures ou de dommages, lire toutes les instructions avant d'installer l'appareil. Porter des lunettes de sécurité. Il faut installer l'appareil en respectant tous les codes de construction et de plomberie locaux et d'État. Appelez un professionnel si vous n'êtes pas certain de la façon d'installer cet appareil. Ce produit a été conçu pour être utilisé avec le Pfister, Moen et Delta dans le mur vannes. Il ne fonctionnera pas avec n'importe quel autre produit de soupape. S'il vous plaît examiner les instructions d'installation complètes avant d'installer ce produit.

Required Tools • Herramientas necesarias • Outils nécessaires



Phillips Screwdriver
Destornillador de cruz
Tournevis cruciforme



PTFE plumber's tape
Cinta para plomería PTFE
Ruban PTFE de plombier



Safety Goggles
Anteojos de seguridad
Lunettes de sûreté

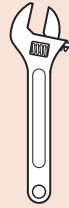

Adjustable Wrench
Llave ajustable
Clé à mollette



Supplied Hex Wrenches
Proveído Llave hexagonales
Clés à six pans fournies

Additional Helpful Tools

Otras herramientas útiles Outils supplémentaires utiles



Cloth
Paño de limpieza
Chiffon

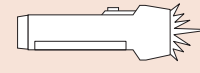

Flashlight
Linterna
Lampe-torche



Putty Knife
Cuchillo de masilla
Couteau de mastic



Caulking or Sealant
Calafateo o sellante
Calféutage ou mastic

Disclaimer • Renuncia • Désistement

This Pfister Trim Kit will not work on the following...

Este kit de ajuste no va a funcionar en el siguiente...

Cette trousse de garniture ne fonctionnera pas sur ce qui suit ...

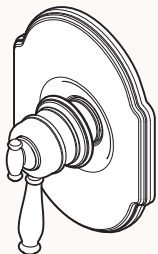
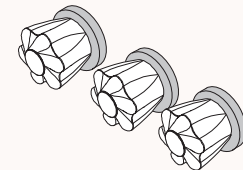

Shower with separate volume and temperature control levers on trim.

Ducha con volumen independiente y las palancas de control de la temperatura sobre el asiento.

Douche avec volume séparé et leviers de commande de température sur l'assiette.

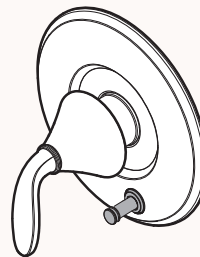

Tub-shower diverter (button or lever) on shower trim.

Bañera-ducha desviador (botón o palanca) sobre el asiento de ducha.

Baignoire-douche inverseur (bouton ou un levier) sur l'assiette de douche.

Two or three handle shower.

Dos o tres ducha de mango.

Deux ou trois de douche poignée.



Before removing existing trim, make sure handle is in off position.

Antes de quitar el ajuste existente, cerciórese de que la manija está en la posición de reposo.

Avant d'enlever l'équilibre existant, assurez-vous que la poignée est dans la position de repos.

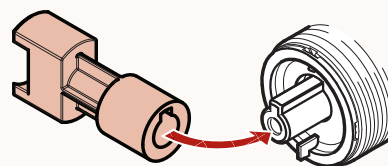

Keyway is aligned.

Estría esta alineada.
Clavette est aligné.

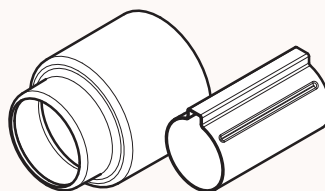

Pull sleeve towards you to minimize gap.

Extraer el casquillo hacia usted para minimizar el espacio.

Enlevez le manchon vers vous afin de minimiser écart.

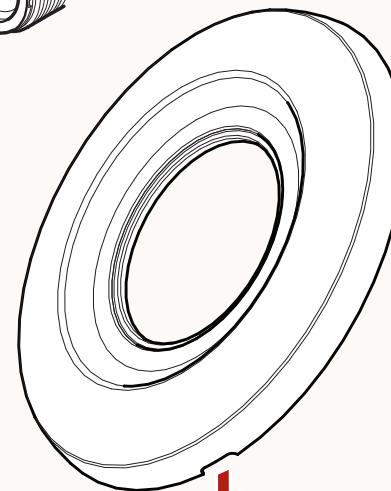

Position flange groove on bottom.

Coloque el surco del reborde en parte inferior.

Placez la cannelure de bride sur le fond.

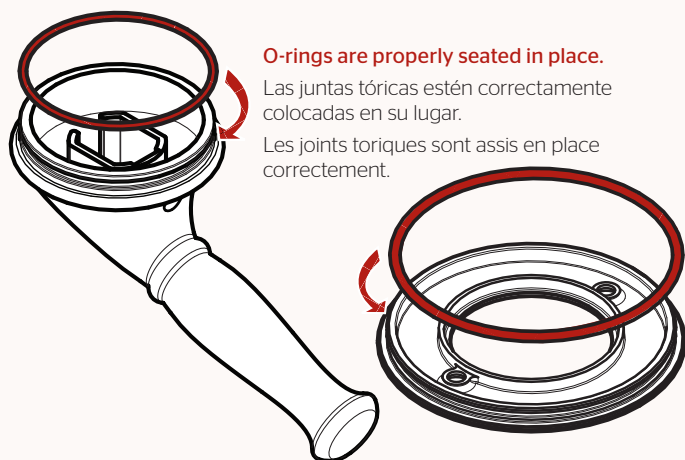

O-rings are properly seated in place.

Las juntas tóricas estén correctamente colocadas en su lugar.

Les joints toriques sont assis en place correctement.

1 Remove existing trim and clean all mounting surfaces.

Ensure the valve stem and all screw holes are debris free.

Tub spout and showerhead are removed in later steps.

Quite el adorno existente y limpie todas las superficies de montaje.

Asegure que el vástago de válvula y todos los agujeros del tornillo sean libres de impurezas.

Salida de la bañera y la ducha se eliminan en pasos posteriores.

Enlevez l'équilibre existant et nettoyez toutes les surfaces de montage.

Assurez que la tige de valve et tous les trous de vis sont des débris libres.

Le bec de bain et de douche sont retirés dans les étapes ultérieures.

Removal Tip: Look for a set screw or a removable cap on existing handle.

Extracción de las puntas: Busque un tornillo de fijación o una tapa extraíble existente en el mango.

Astuce Enlèvement: Rechercher un vis de réglage ou un capuchon amovible sur la poignée existante.

2

Identify your Delta valve

Identifique su válvula Delta

Identifiez votre robinet Delta

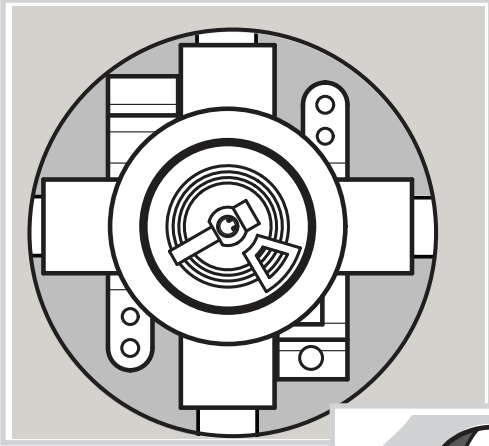

Delta Monitor - Go to Step 3

Delta Monitor - Vaya al paso 3

Delta Monitor- Passez à l'étape 3

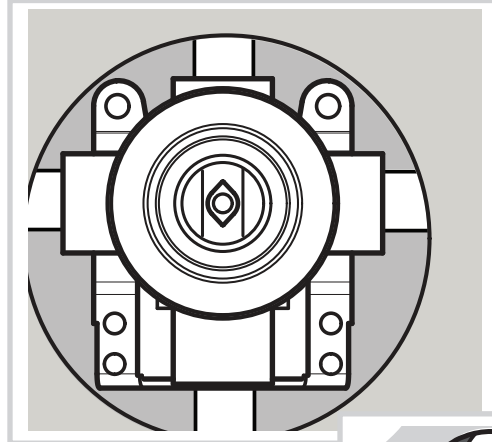
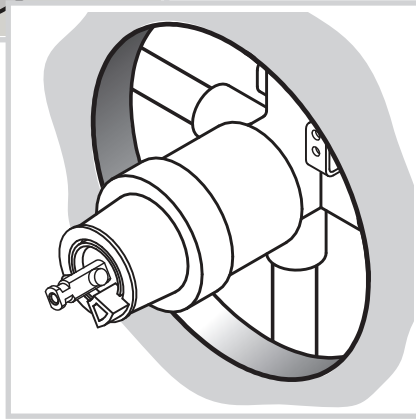

Delta 600 Diamond Stem

- **Go to Step 4**

Delts 600 Diamond Stem

- Vaya al paso 4

Delts 600 Diamond Stem

- Passez à l'étape 4

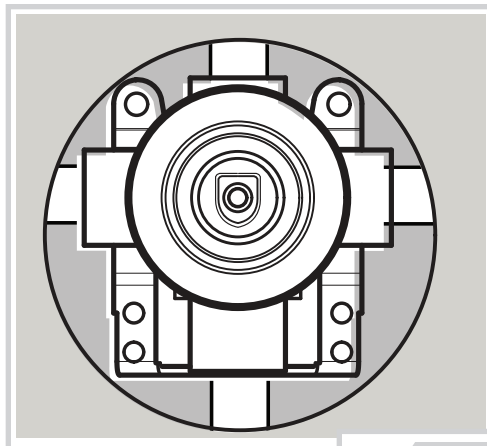
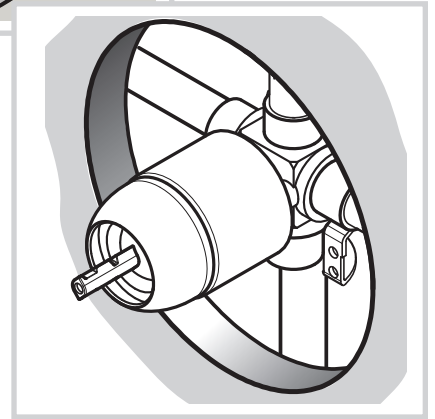

Delta 600 Round Stem

- **Go to Step 5**

Delts 600 Round Stem

- Vaya al paso 5

Delts 600 Round Stem

- Passez à l'étape 5

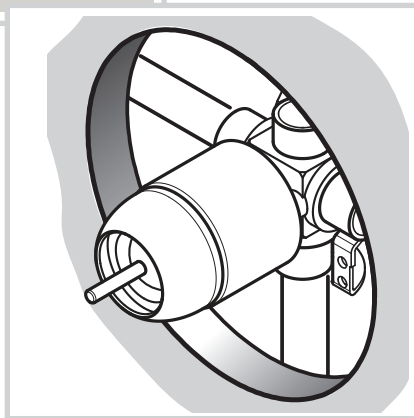

2

Identify your Moen valve

Identifique su válvula Moen

Identifiez votre robinet Moen

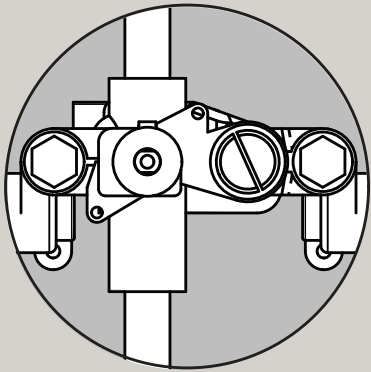

Moen Moentrol - Go to Step 6
Moen Moentrol - Vaya al paso 6
Moen Moentrol - Passez à l'étape 6

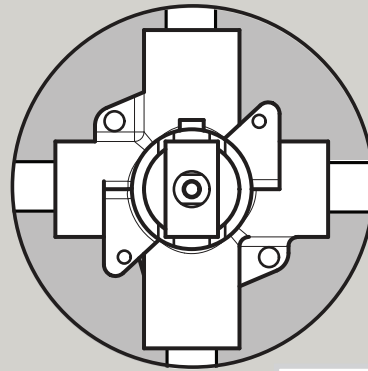
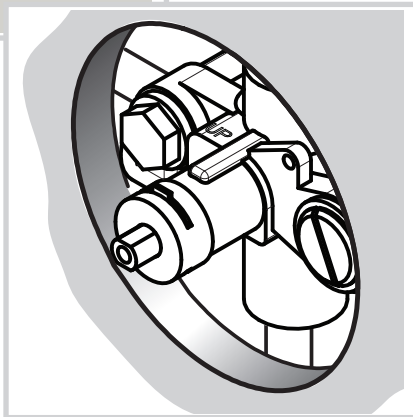

Moen Posi-Temp - Go to Step 7
Moen Posi-Temp - Vaya al paso 7
Moen Posi-Temp - Passez à l'étape 7

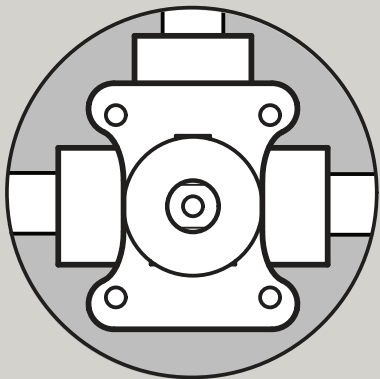
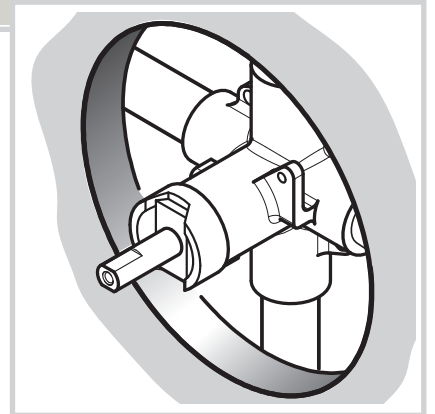

Moen Standard - Go to Step 8
Moen Standard - Vaya al paso 8
Moen Standard - Passez à l'étape 8

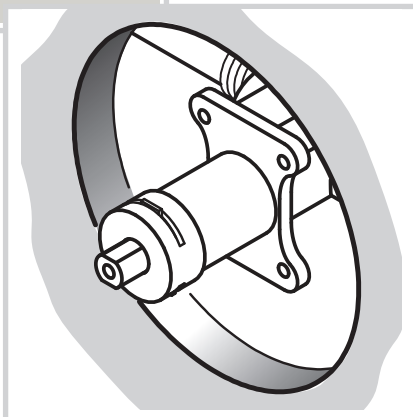

Pfister sleeve

Pfister manga
Manchon Pfister

Existing sleeve

Alojamiento existente
Manchon existant

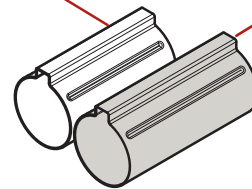

If existing sleeve (shown) is longer than new Pfister sleeve, please contact Pfister to order part 972-064.

Si acabado existentes (se muestra) es más largo que nuevo ajuste de Pfister, póngase en contacto con Pfister a pedido de parte 972-064.

Si garniture existante (voir photo) est plus longue que garniture nouvelle Pfister, s'il vous plaît contactez-Pfister pour commander la partie 972-064.

2

Identify your Pfister valve

Identifique su válvula Pfister

Identifiez votre robinet Pfister

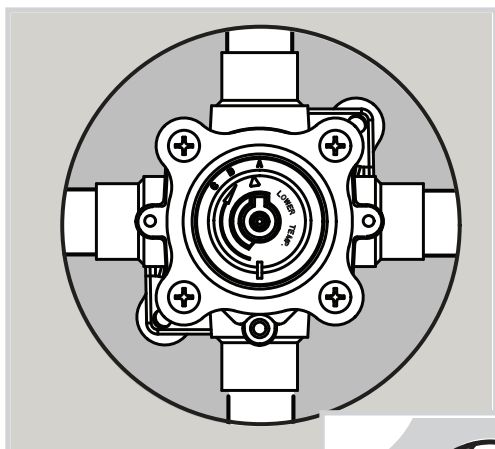

Pfister - Go to Step 9

Pfister - Vaya al paso 9

Pfister - Passez à l'étape 9

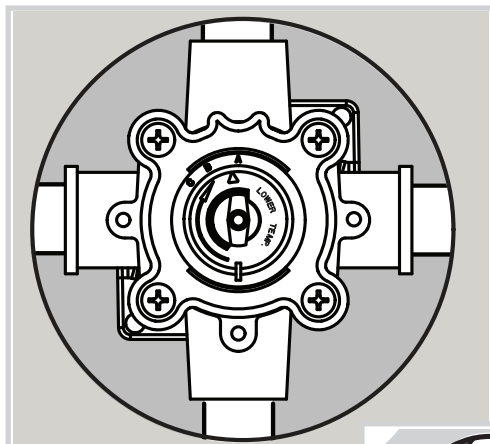
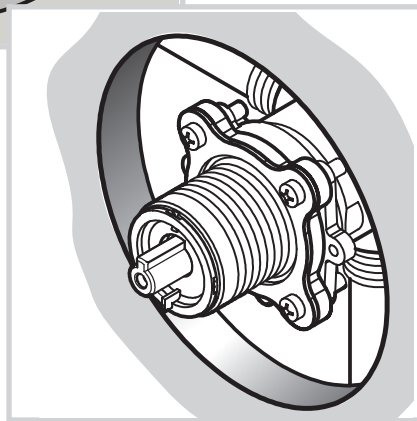

Pfister, Bodyguard - Go to Step 10

Pfister Bodyguard - Vaya al paso 10

Pfister Bodyguard - Passez à l'étape 10

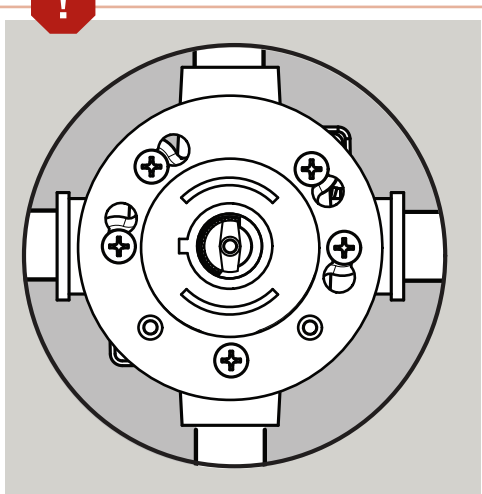
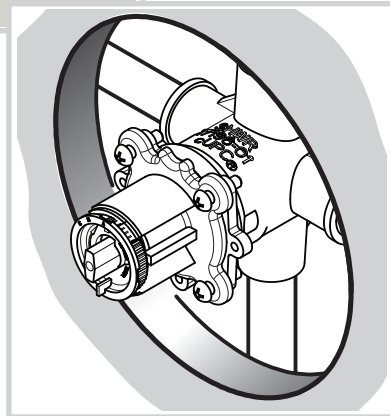

If your Pfister valve is as shown, please contact Pfister to order replacement Cartridge 974-042, Screws 971-910 and Plate 960-460. Then go to Step 10.

Si su válvula de Pfister es como se muestra, por favor póngase en contacto con Pfister para el reemplazo del Cartucho 974-042, Tornillos 971-910 y Placa 960-460. Vaya al paso 10.

Si votre robinet est Pfister comme le montre, s'il vous plaît contactez-Pfister au remplacement afin Cartouche Vis 974-042, 971-910 et Plaque 960-460. Passez à l'étape 10

3

Installing Delta Monitor Trim Instalación Delta Monitor adorno Installation Delta Monitor équilibre

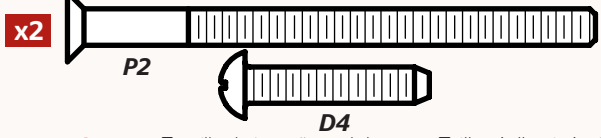

Actual size screw to use • Tornillo de tamaño real de usar • Taille réelle vis à utiliser



Phillips Screwdriver
 Destornillador de estrella
 Tournevis Phillips



Supplied Hex Wrench
 Proveedor Llave hexagonal
 Fourni Clé hexagonale

Parts in tray are organized together.

Las piezas en la bandeja se organizan juntos.

Organisé dans certaines parties de plateau sont ensemble.

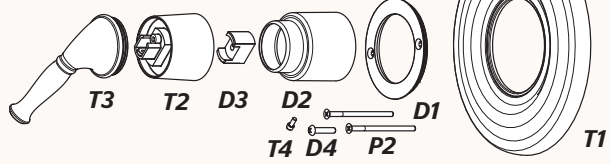

3A

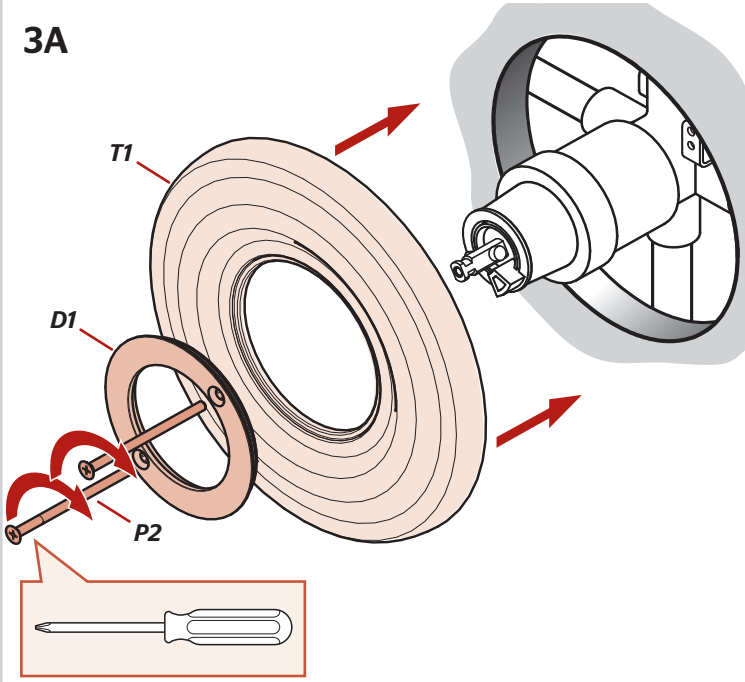

3B

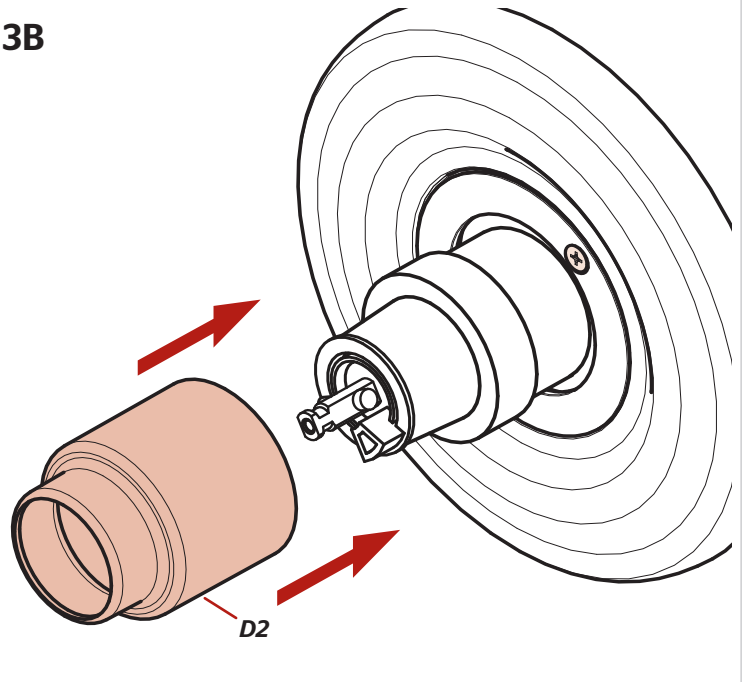

3C

Helpful Hint: Adaptor is white in color

Sugerencia: Adaptador es de color blanco

Conseil utile: Adaptateur est de couleur blanche

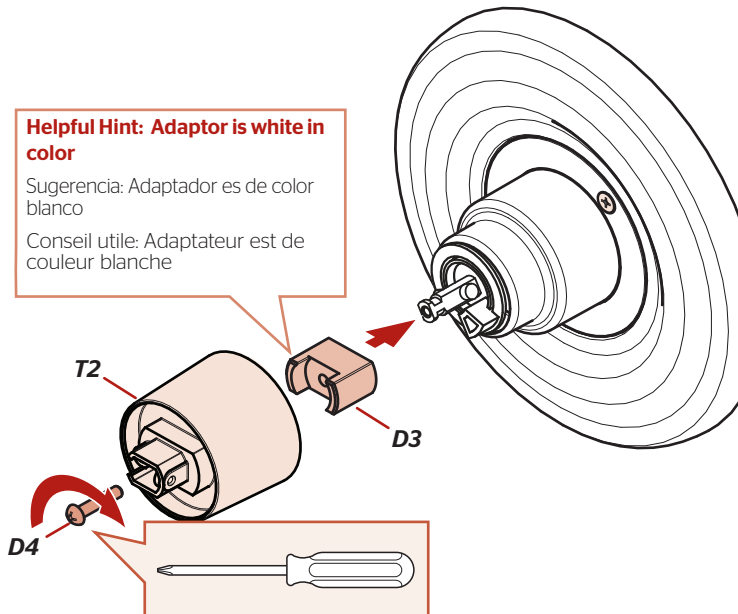

3D

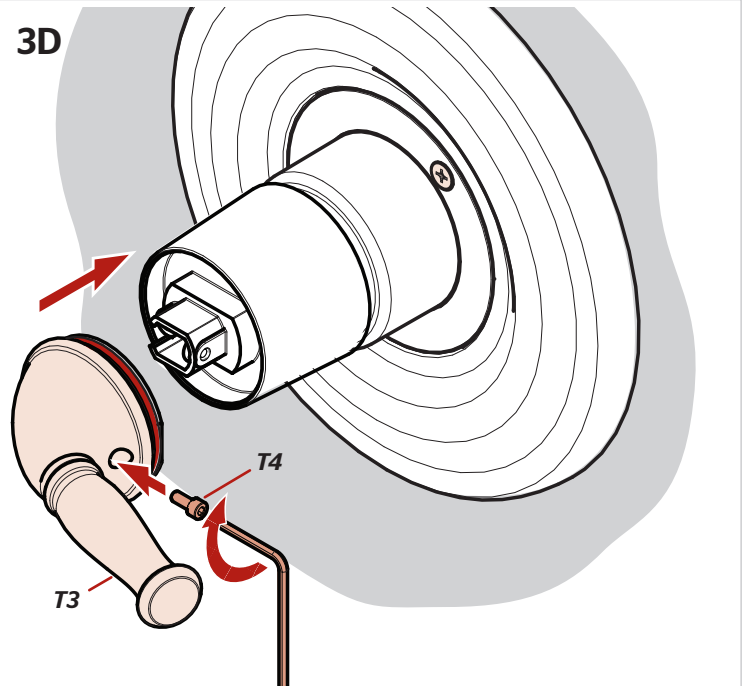

Go to Step 11
 Vaya al paso 11
 Passez à l'étape 11



4 Installing Delta 600 Diamond Stem Trim

Instalación 600 Diamond Stem adorno

Installation 600 Diamond Stem équilibre

x2

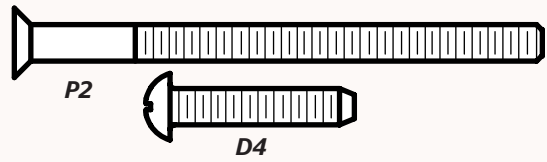

Actual screw size to use • Tornillo de tamaño real de usar • Taille réelle vis à utiliser



Phillips Screwdriver
Destornillador de estrella
Tournevis Phillips



Supplied Hex Wrench
Proveído Llave hexagonal
Fourni Clé hexagonale

Parts in tray are organized together.

Las piezas en la bandeja se organizan juntos.

Organisé dans certaines parties de plateau sont ensemble.

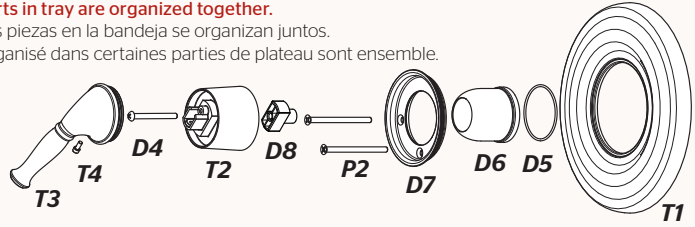

4A

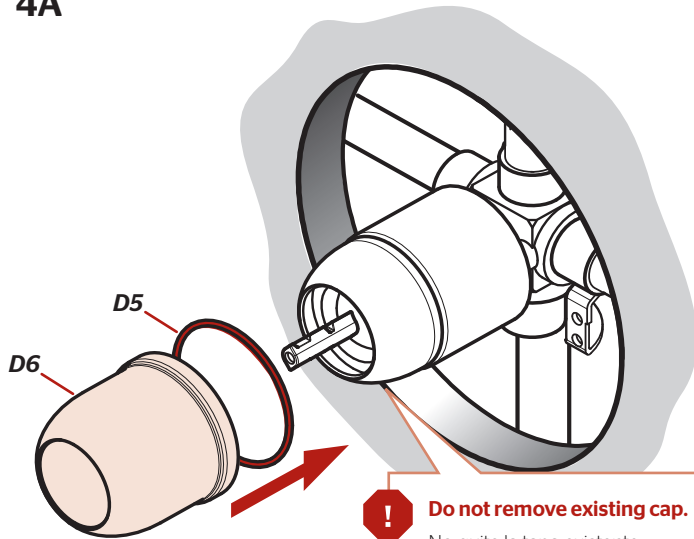

Do not remove existing cap.

No quite la tapa existente.

Ne retirez pas le capuchon existant.

4B

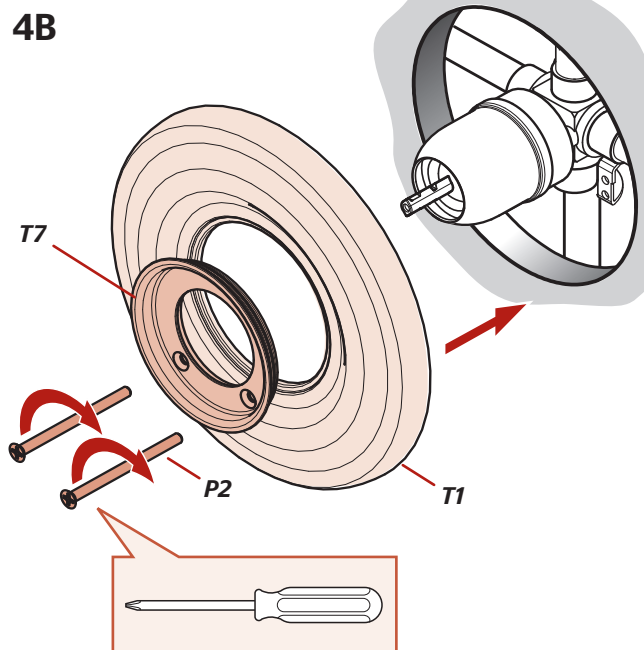

4C

Helpful Hint: Adaptor is white in color

Sugerencia: Adaptador es de color blanco

Conseil utile: Adaptateur est de couleur blanche

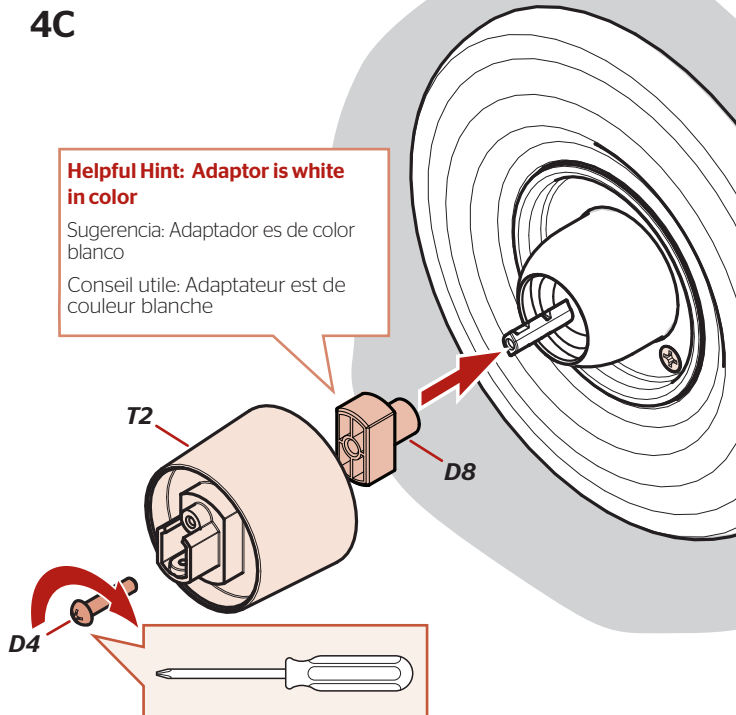

4D

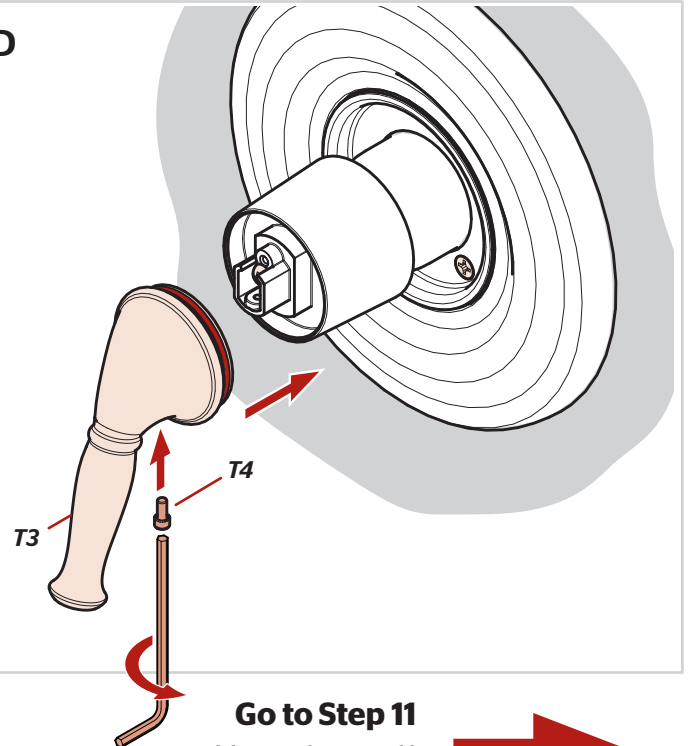

Go to Step 11

Vaya al paso 11

Passez à l'étape 11



5 Installing Delta 600 Round Stem Trim

Instalación 600 Round Stem adorno

Installation 600 Round Stem équilibre



Phillips Screwdriver
Destornillador de estrella
Tournevis Phillips

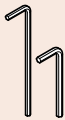

Supplied Hex Wrenches
Proveído Llave hexagonales
Clés à six pans fournies

x2

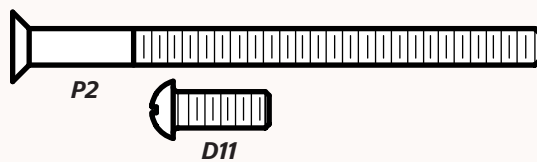

Actual screw size to use • Tornillo de tamaño real de usar • Taille réelle vis à utiliser

Parts in tray are organized together.

Las piezas en la bandeja se organizan juntos.

Organisé dans certaines parties de plateau sont ensemble.

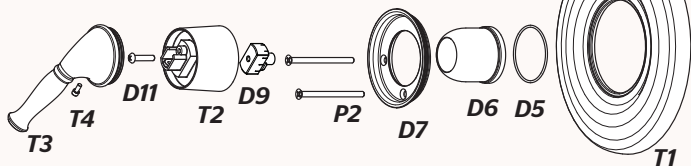

5A

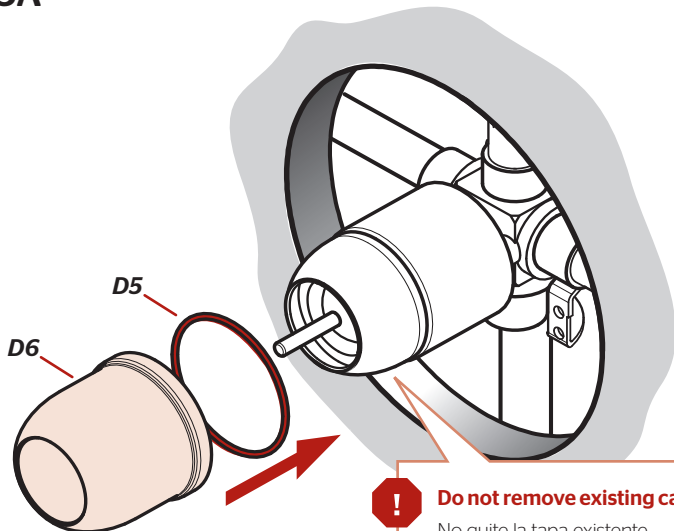

Do not remove existing cap.
No quite la tapa existente.
Ne retirez pas le capuchon existant.

5B

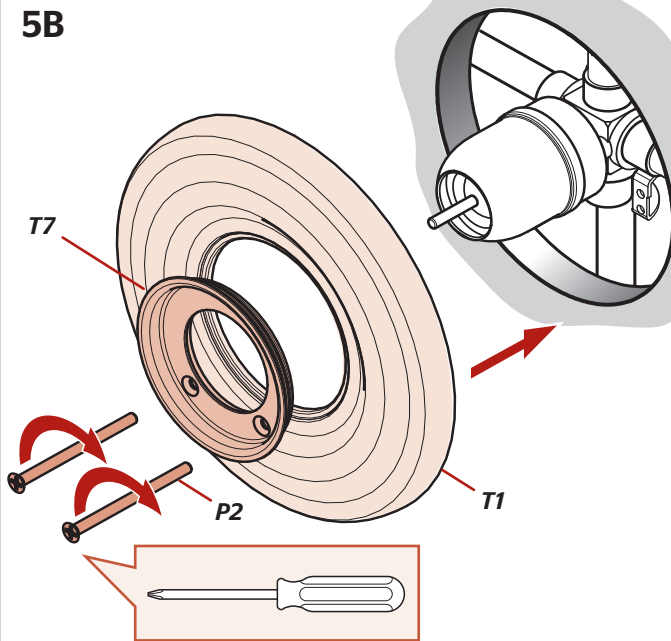

5C

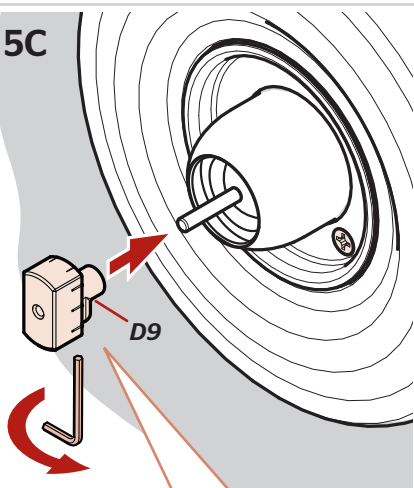

Helpful Hint: Adaptor is gray in color

Sugerencia: Adaptador es de color gris

Conseil utile: Adaptateur est de couleur grise

5D

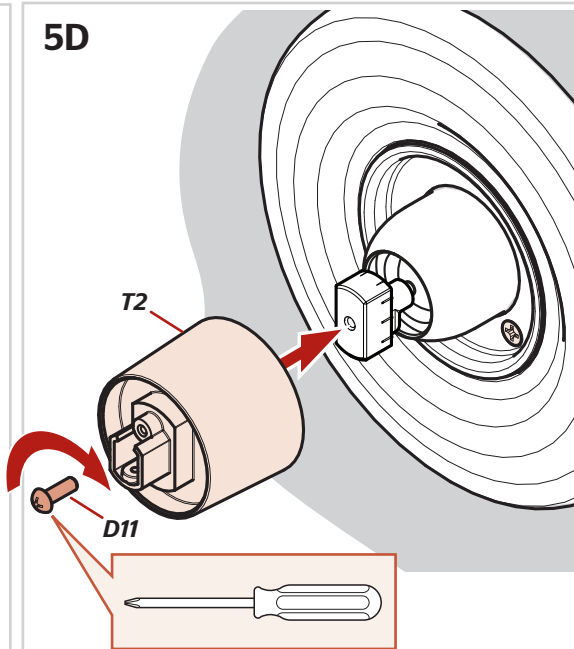

5E

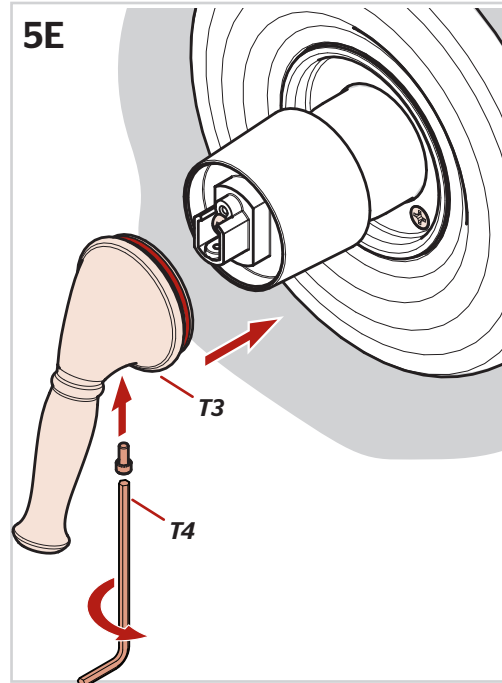

Go to Step 11
Vaya al paso 11
Passez à l'étape 11

6 Installing Moen Moentrol Trim

Instalación Moen Moentrol adorno
Installation Moen Moentrol équilibre



Phillips Screwdriver
Destornillador de estrella
Tournevis Phillips

x2

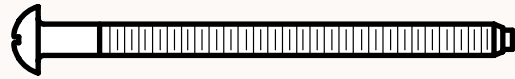

M2

Actual screw size to use • Tornillo de tamaño real de usar • Taille réelle vis à utiliser

Parts in tray are organized together.

Las piezas en la bandeja se organizan juntos.
Organisé dans certaines parties de plateau
sont ensemble.



M6

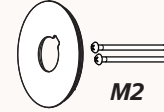

M2



M1

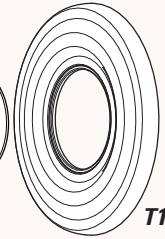

T1

6A

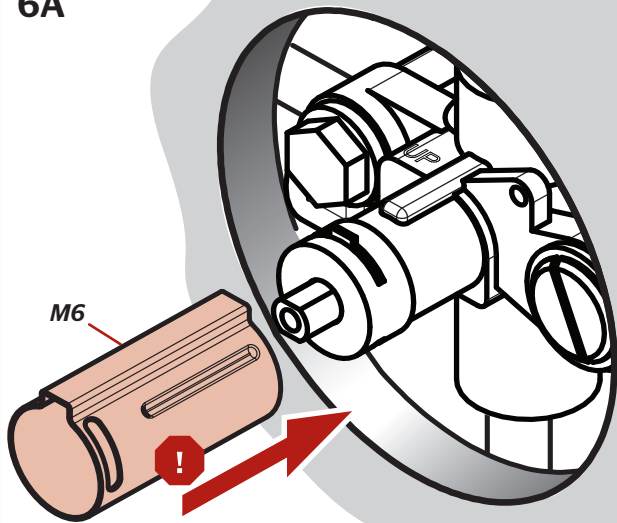

6B

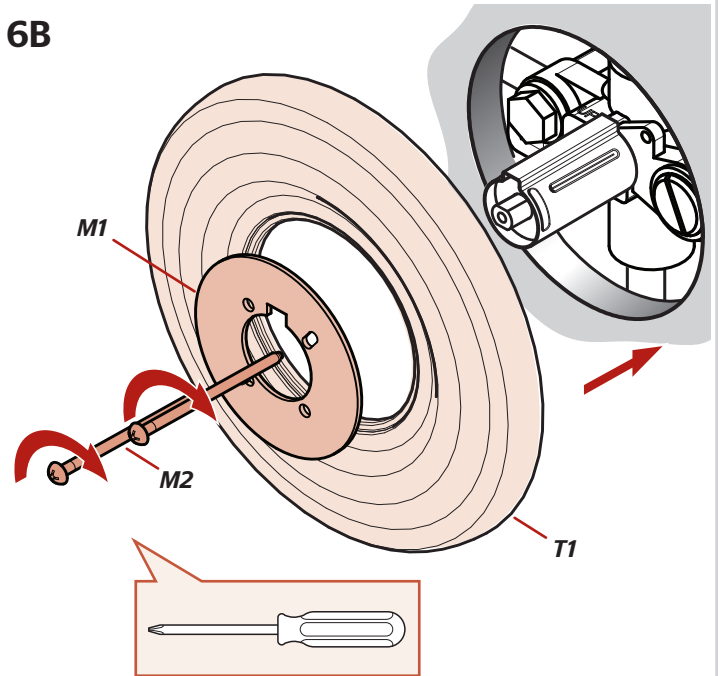

6C

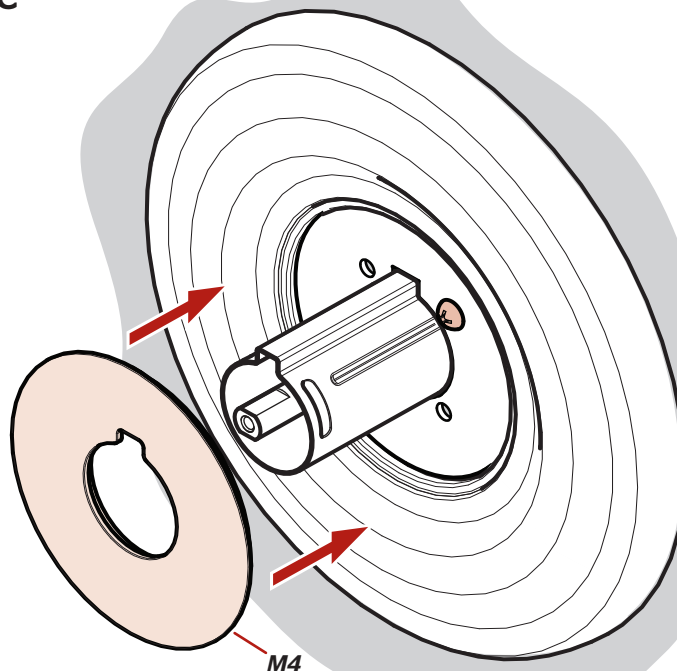

Continue
Seguido
Suite



6 Moen Moentrol Trim - Continued

Moen Moentrol adorno - Seguido

Moen Moentrol équilibre - Suite



M9

Actual screw size to use • Tornillo de tamaño real de usar • Taille réelle vis à utiliser



Phillips Screwdriver
Destornillador de estrella
Tournevis Phillips



Supplied Hex Wrench
Proveído Llave hexagonal
Fourni Clé hexagonale

Parts in tray are organized together.

Las piezas en la bandeja se organizan juntos.

Organisé dans certaines parties de plateau sont ensemble.

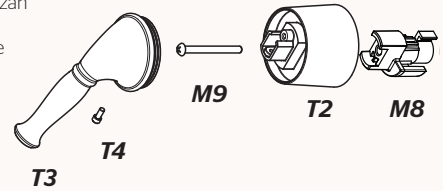

6D

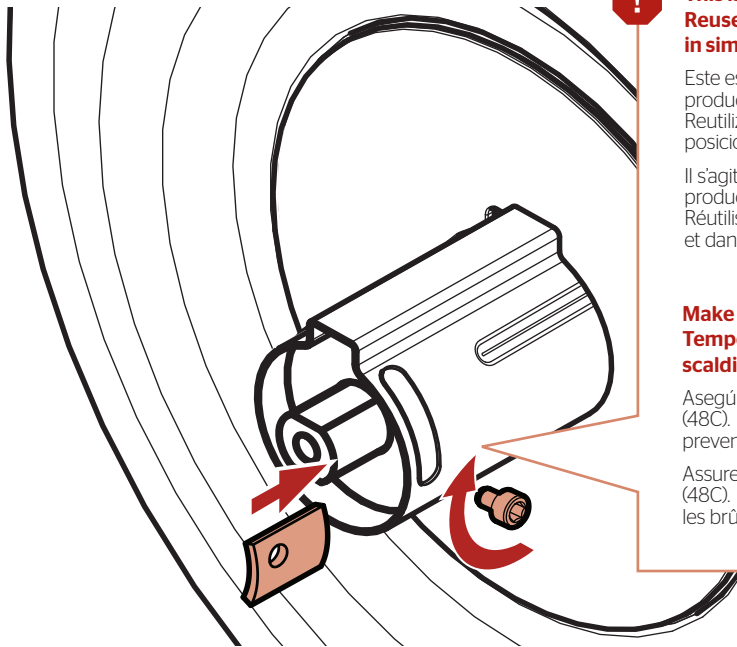

This is a temperature limiting device. Position to limit hot water output. Reuse existing stop and screw. Notice location on existing and position in similar location on new sleeve.

Este es un dispositivo de limitación de temperatura. Coloque limitar la producción de agua caliente. Reutilización de parada existente y el tornillo. Tenga en cuenta la ubicación de la posición actual y en similar ubicación en la manga de nuevo.

Il s'agit d'un dispositif de limitation de la température. Position pour limiter la production d'eau chaude. Réutilisation d'arrêt existant et vissez. Avis emplacement sur la position actuelle et dans un endroit similaire sur la manche nouvelle.

Make sure maximum hot water temperature does not exceed 120F (48C). Temperature setting at the water heater may be required to prevent scalding.

Asegúrese de que la temperatura máxima del agua caliente no sea superior a 120F (48C). Ajuste de la temperatura en el calentador de agua puede ser necesaria para prevenir quemaduras.

Assurez-vous que la température maximale de l'eau chaude ne dépasse pas 120F (48C). Réglage de la température à la chauffe-eau peut être nécessaire pour éviter les brûlures.

6E

Helpful Hint: Adaptor is white in color

Sugerencia: Adaptador es de color blanco

Conseil utile: Adaptateur est de couleur blanche

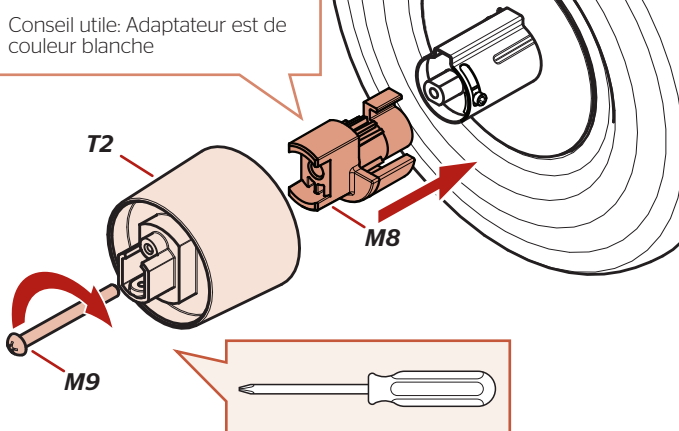

6F

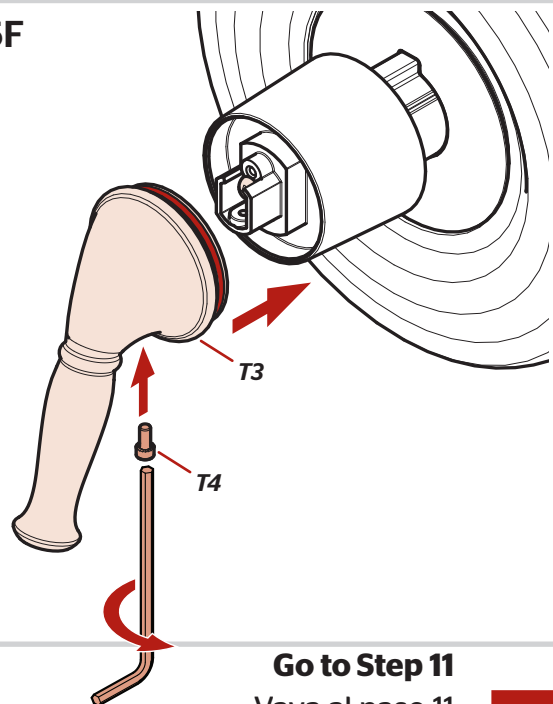

Go to Step 11
Vaya al paso 11
Passez à l'étape 11



7 Installing Moen Posi-Temp Trim

Instalación Moen Posi-Temp adorno
Installation Moen Posi-Temp équilibre

x2



M2

Actual screw size to use • Tornillo de tamaño real de usar • Taille réelle vis à utiliser



Phillips Screwdriver
Destornillador de estrella
Tournevis Phillips

Parts in tray are organized together.

Las piezas en la bandeja se organizan juntos.

Organisé dans certaines parties de plateau sont ensemble.

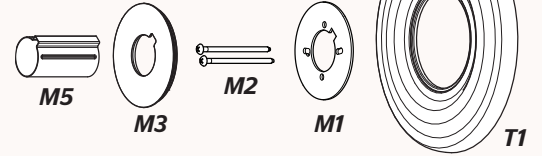

7A

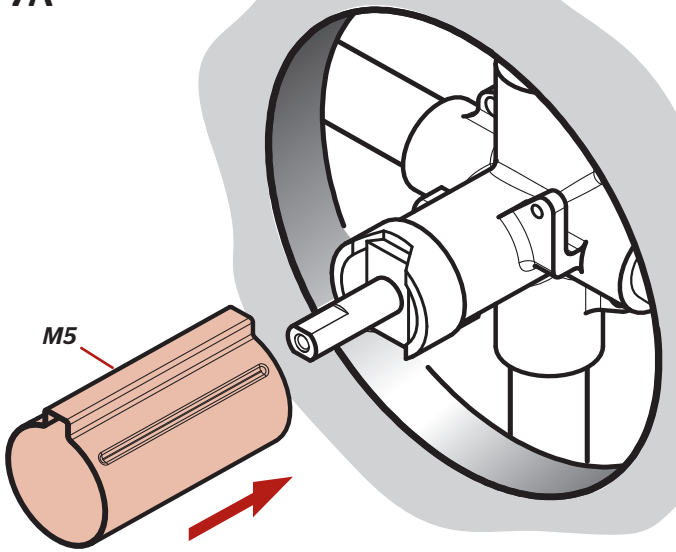

7B

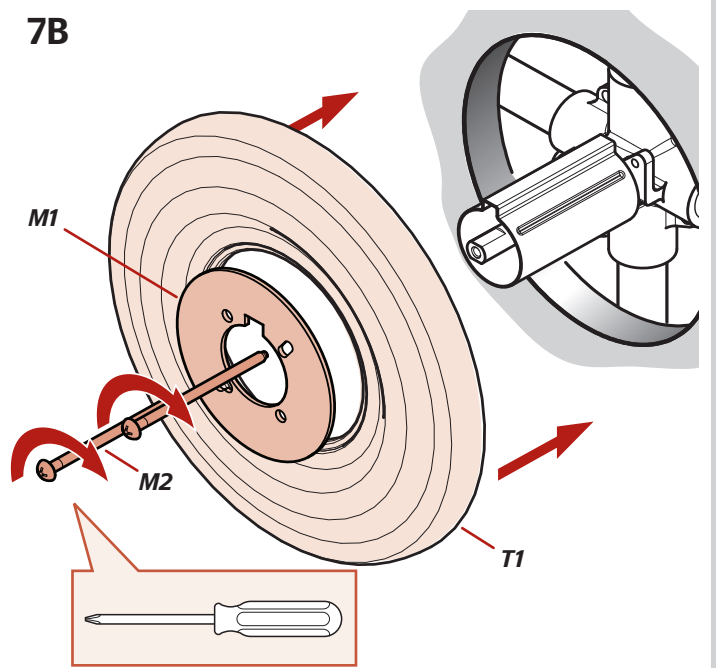

7C

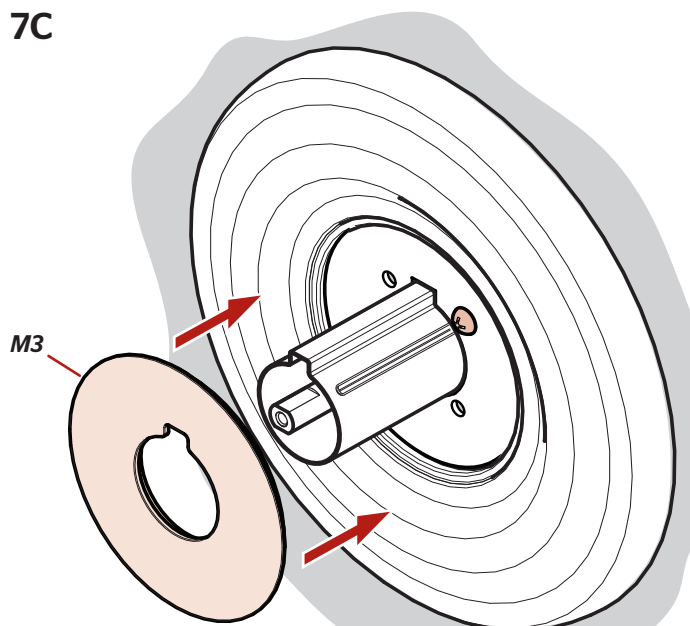

Continue
Seguido
Suite



7 Installing Moen Posi-Temp - Continued

Instalación Moen Posi-Temp adorno - Seguido

Installation Moen Posi-Temp équilibre - Suite

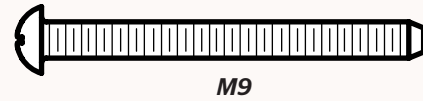

M9

Actual screw size to use • Tornillo de tamaño real de usar • Taille réelle vis à utiliser



Phillips Screwdriver
Destornillador de estrella
Tournevis Phillips



Supplied Hex Wrench
Proveído Llave hexagonal
Fourni Clé hexagonale

Parts in tray are organized together.
Las piezas en la bandeja se organizan juntos.
Organisé dans certaines parties de plateau sont ensemble.

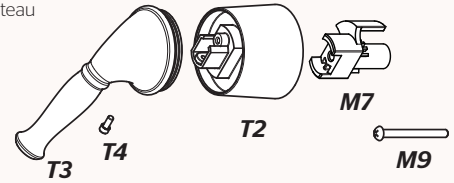

7D

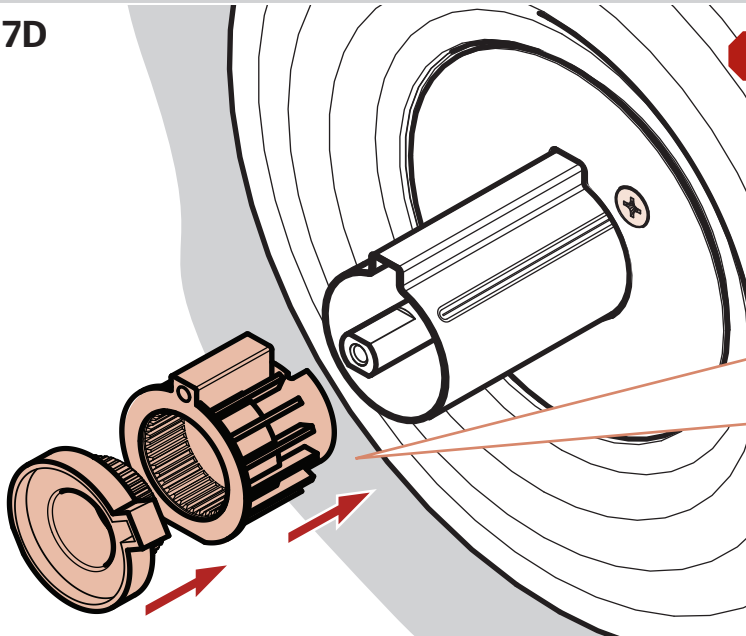

This is a temperature limiting device. Position to limit hot water output. Reuse existing insert and stop cap. Notice location on existing and position in similar location on new sleeve.

Este es un dispositivo de limitación de temperatura. Coloque limitar la producción de agua caliente. Reutilización de inserción existentes y la tapa de la parada. Tenga en cuenta la ubicación de la posición actual y en similar ubicación en la manga de nuevo.

Il s'agit d'un dispositif de limitation de la température. Position pour limiter la production d'eau chaude. Réutiliser insert existant et le bouchon d'arrêt. Avis emplacement sur la position actuelle et dans un endroit similaire sur la manche nouvelle.

Make sure maximum hot water temperature does not exceed 120F (48C). Temperature setting at the water heater may be required to prevent scalding.

Asegúrese de que la temperatura máxima del agua caliente no sea superior a 120F (48C). Ajuste de la temperatura en el calentador de agua puede ser necesaria para prevenir quemaduras.

Assurez-vous que la température maximale de l'eau chaude ne dépasse pas 120F (48C). Réglage de la température à la chauffe-eau peut être nécessaire pour éviter les brûlures.

7E

Helpful Hint: Adaptor is white in color

Sugerencia: Adaptador es de color blanco

Conseil utile: Adaptateur est de couleur blanche

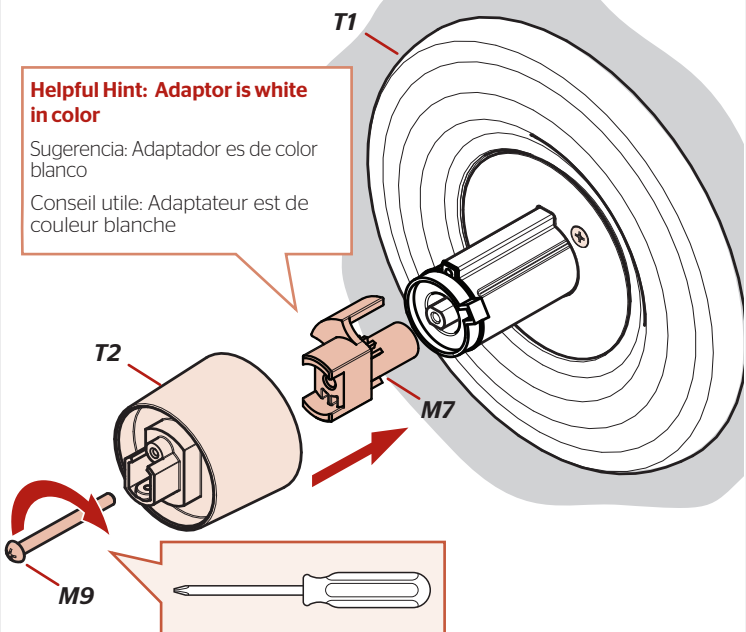

7F

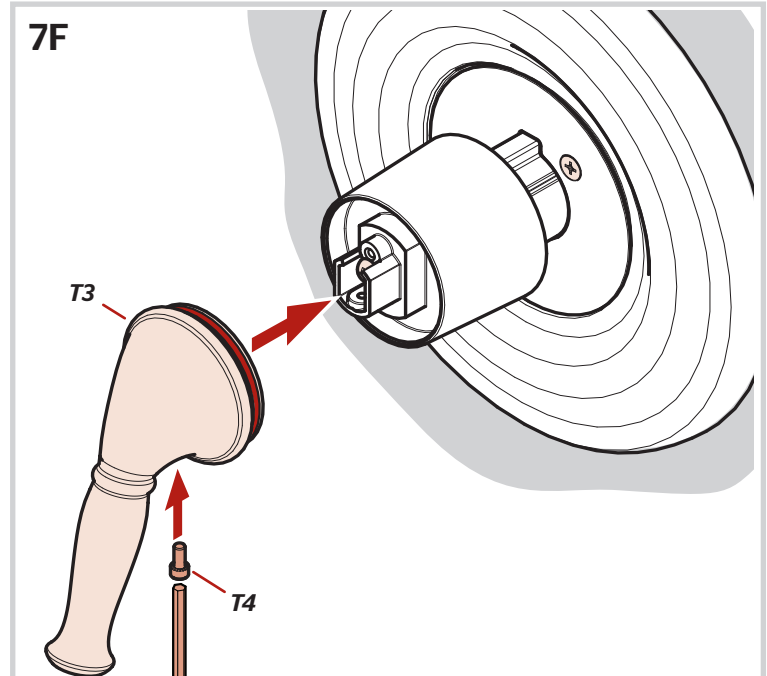

Go to Step 11
Vaya al paso 11
Passez à l'étape 11



8 Installing Moen Standard Trim

Instalación Moen Standard adorno
Installation Moen Standard équilibre

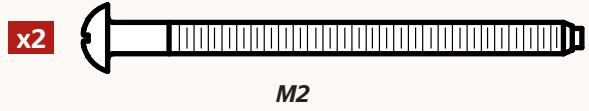

Actual screw size to use • Tornillo de tamaño real de usar • Taille réelle vis à utiliser



Phillips Screwdriver
Destornillador de estrella
Tournevis Phillips

Parts in tray are organized together.

Las piezas en la bandeja se organizan juntos.
Organisé dans certaines parties de plateau sont ensemble.

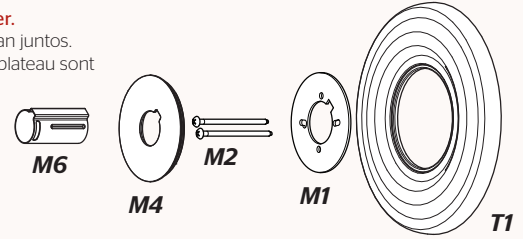

8A

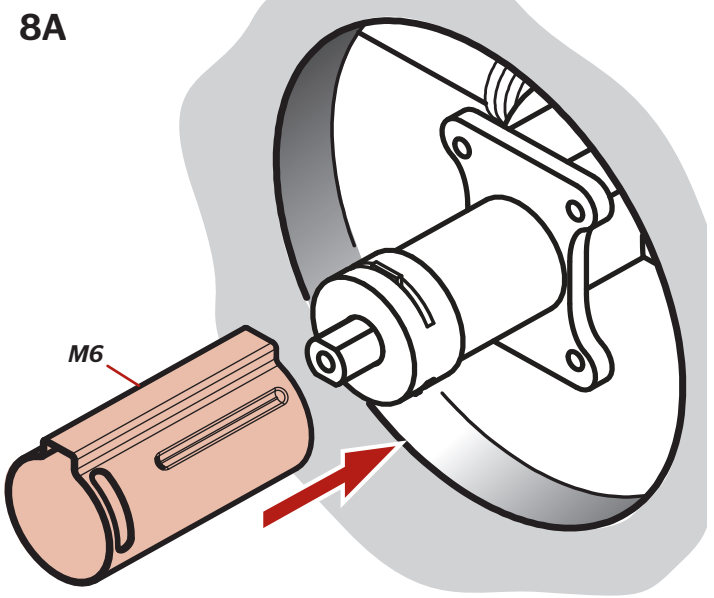

8B

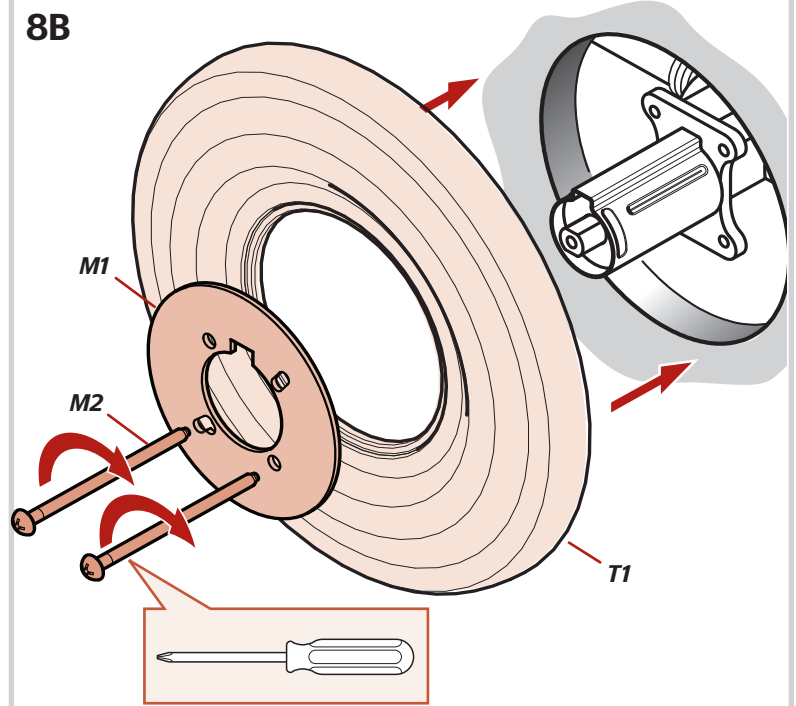

8C

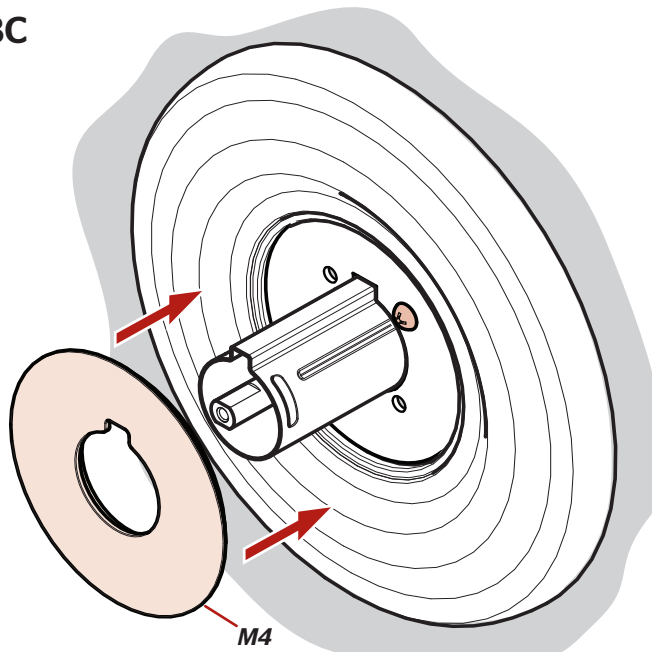

Continue
Seguido
Suite



8 Installing Moen Standard Trim

Instalación Moen Standard adorno

Installation Moen Standard équilibre



M9

Actual screw size to use • Tornillo de tamaño real de usar • Taille réelle vis à utiliser



Phillips Screwdriver
Destornillador de estrella
Tournevis Phillips



Supplied Hex Wrench
Proveído Llave hexagonal
Fourni Clé hexagonale

Parts in tray are organized together.

Las piezas en la bandeja se organizan juntos.
Organisé dans certaines parties de plateau sont ensemble.

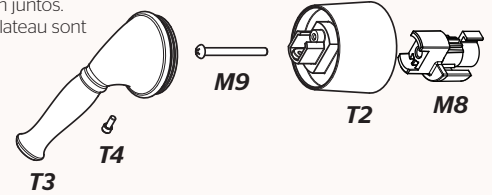

8D

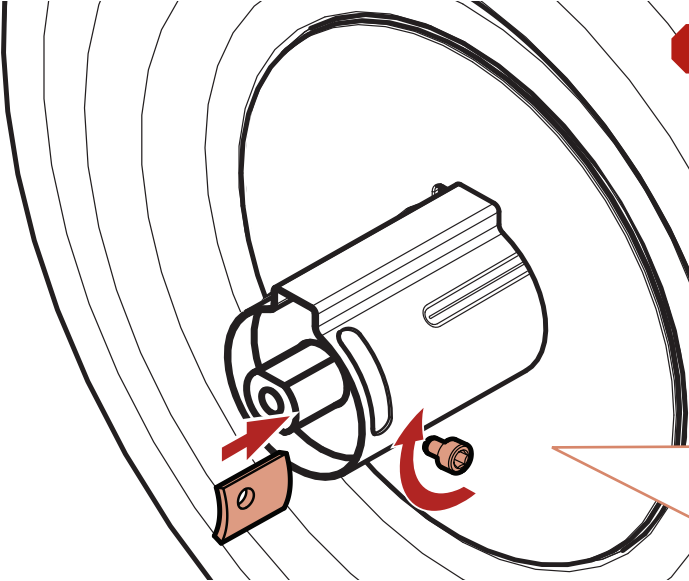

This is a temperature limiting device. Position to limit hot water output. Reuse existing stop and screw. Notice location on existing and position in similar location on new sleeve.

Este es un dispositivo de limitación de temperatura. Coloque limitar la producción de agua caliente. Reutilización de parada existente y el tornillo. Tenga en cuenta la ubicación de la posición actual y en similar ubicación en la manga de nuevo.

Il s'agit d'un dispositif de limitation de la température. Position pour limiter la production d'eau chaude. Réutilisation d'arrêt existant et vissez. Avis emplacement sur la position actuelle et dans un endroit similaire sur la manche nouvelle.

Make sure maximum hot water temperature does not exceed 120F (48C). Temperature setting at the water heater may be required to prevent scalding.

Asegúrese de que la temperatura máxima del agua caliente no sea superior a 120F (48C). Ajuste de la temperatura en el calentador de agua puede ser necesaria para prevenir quemaduras.

Assurez-vous que la température maximale de l'eau chaude ne dépasse pas 120F (48C). Réglage de la température à la chauffe-eau peut être nécessaire pour éviter les brûlures.

8E

Helpful Hint: Adaptor is white in color

Sugerencia: Adaptador es de color blanco

Conseil utile: Adaptateur est de couleur blanche

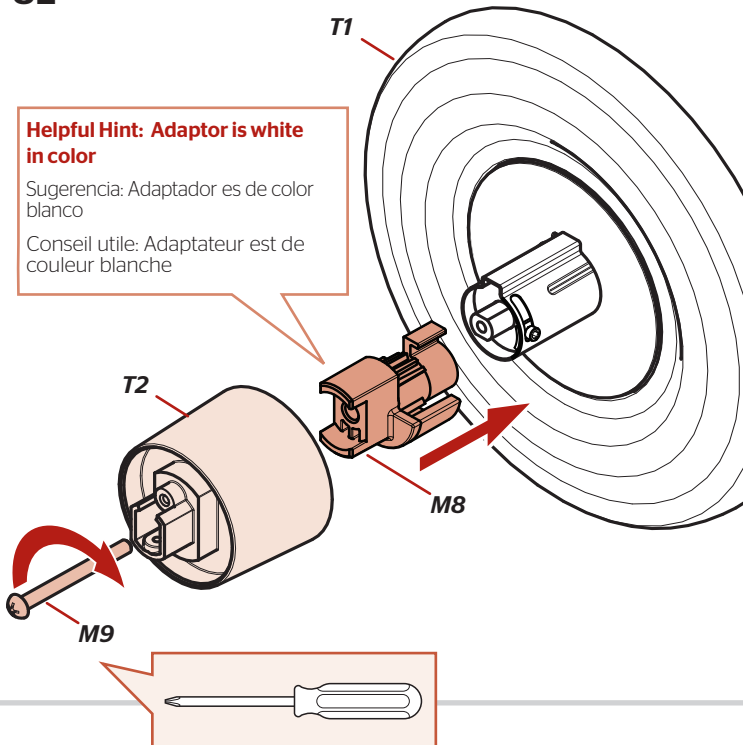

8F

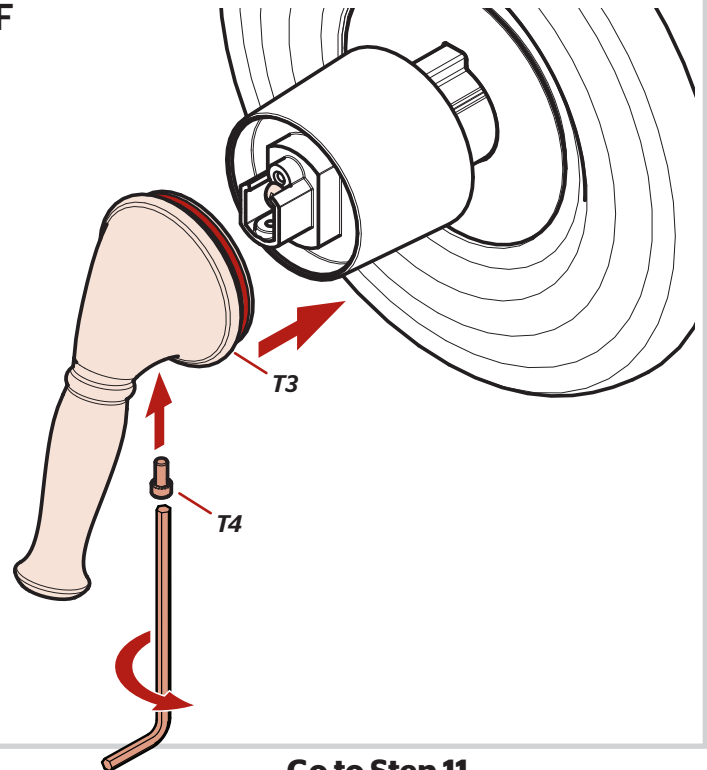

Go to Step 11
Vaya al paso 11
Passez à l'étape 11



9 Installing Pfister Standard Trim

Instalación Pfister Estándar adorno

Installation Pfister Standard équilibre



Phillips Screwdriver
Destornillador de estrella
Tournevis Phillips



Supplied Hex Wrench
Proveído Llave hexagonal
Fourni Clé hexagonale

x2

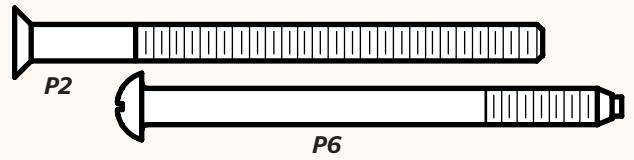

Actual screw size to use • Tornillo de tamaño real de usar • Taille réelle vis à utiliser

Parts in tray are organized together.

Las piezas en la bandeja se organizan juntos.

Organisé dans certaines parties de plateau sont ensemble.

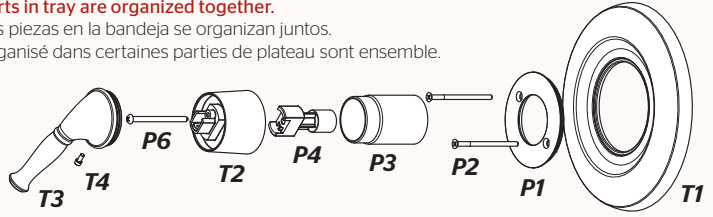

9A

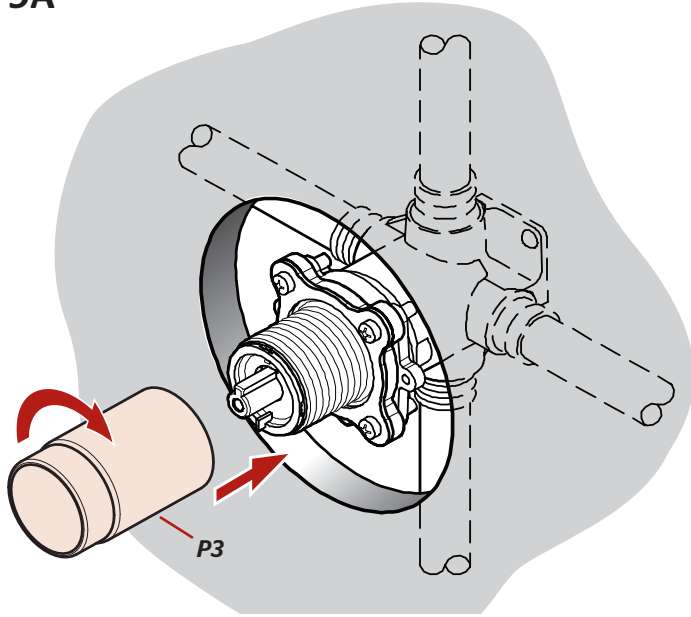

9B

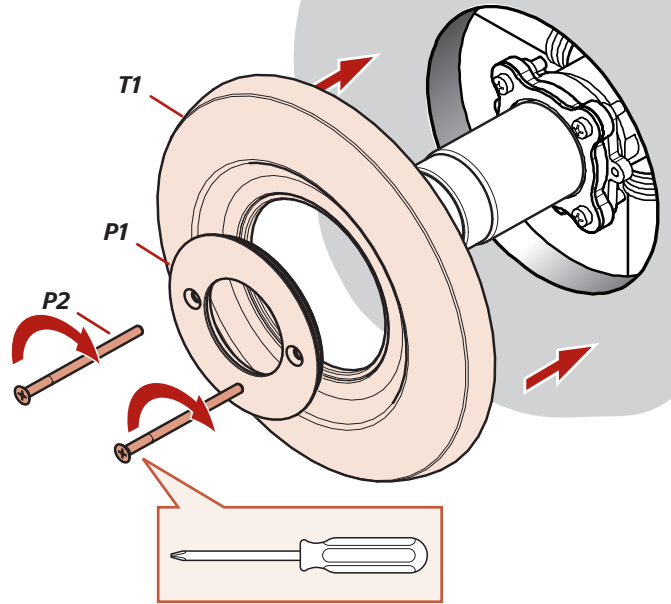

9C

Helpful Hint: Adaptor is white in color

Sugerencia: Adaptador es de color blanco

Conseil utile: Adaptateur est de couleur blanche

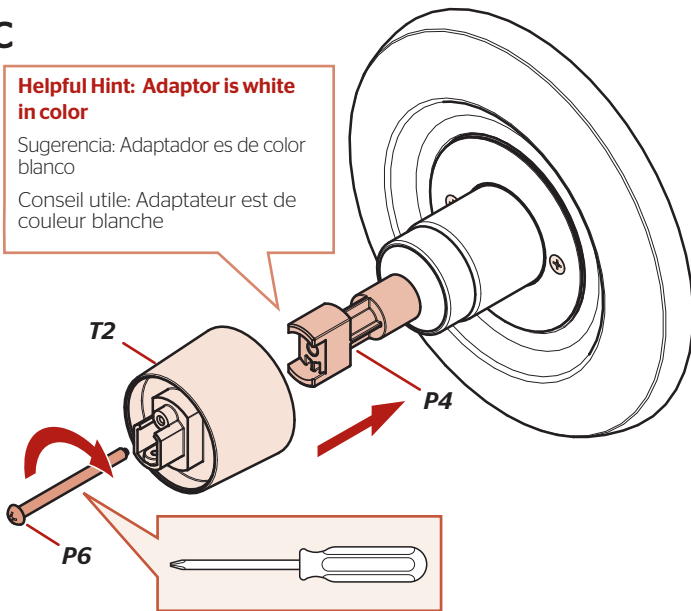

9D

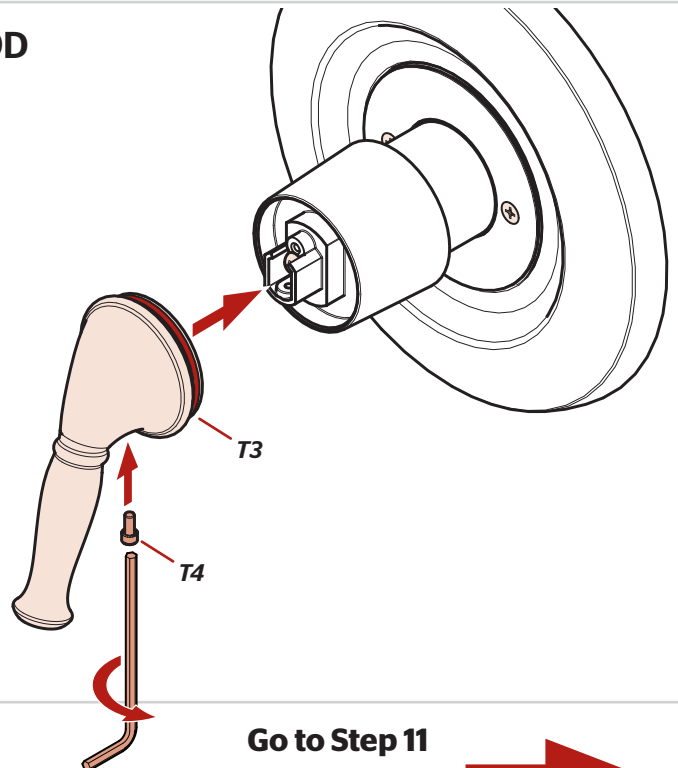

Go to Step 11
Vaya al paso 11
Passez à l'étape 11



10 Installing Pfister Bodyguard Trim

Instalación Pfister Bodyguard adorno

Installation Pfister Bodyguard équilibre

x2

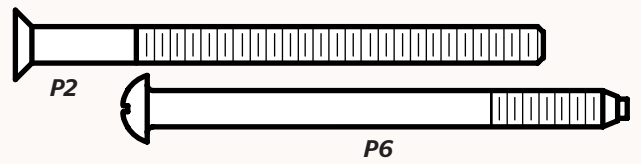

Actual screw size to use • Tornillo de tamaño real de usar • Taille réelle vis à utiliser



Phillips Screwdriver
Destornillador de estrella
Tournevis Phillips



Supplied Hex Wrench
Proveído Llave hexagonal
Fourni Clé hexagonale

Parts in tray are organized together.

Las piezas en la bandeja se organizan juntos.

Organisé dans certaines parties de plateau sont ensemble.

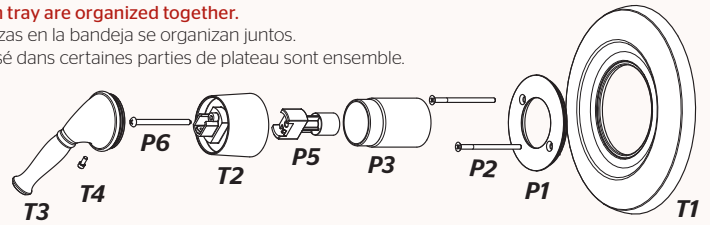

10A

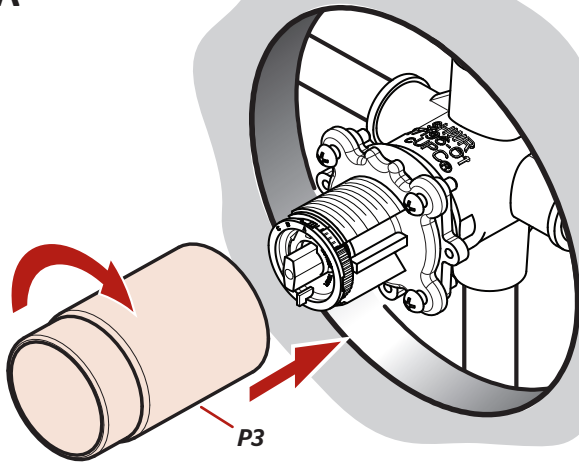

10B

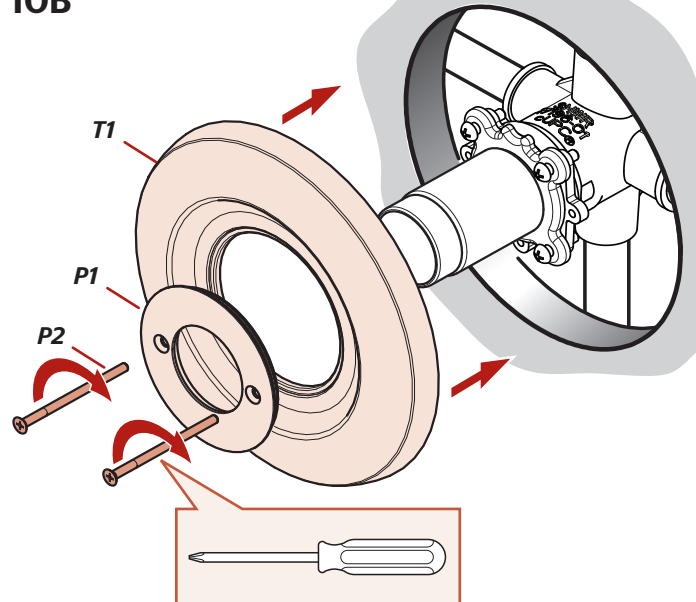

10D

Helpful Hint: Adaptor is gray in color

Sugerencia: Adaptador es de color gris

Conseil utile: Adaptateur est de couleur grise

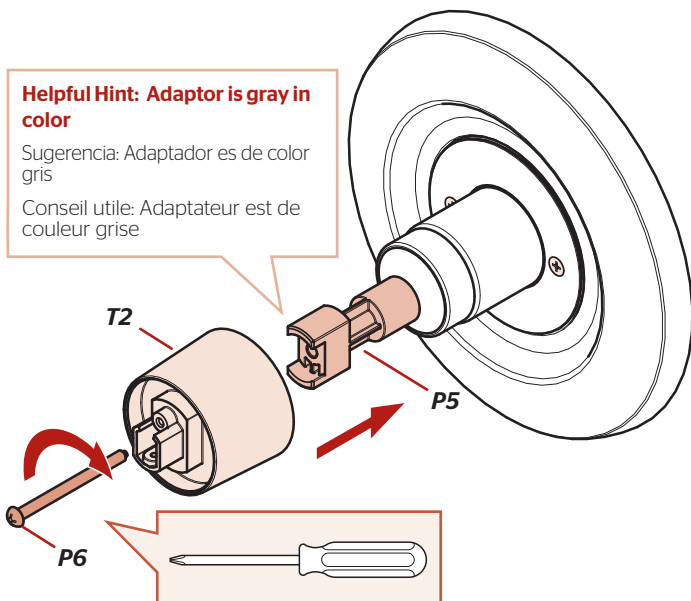

10D

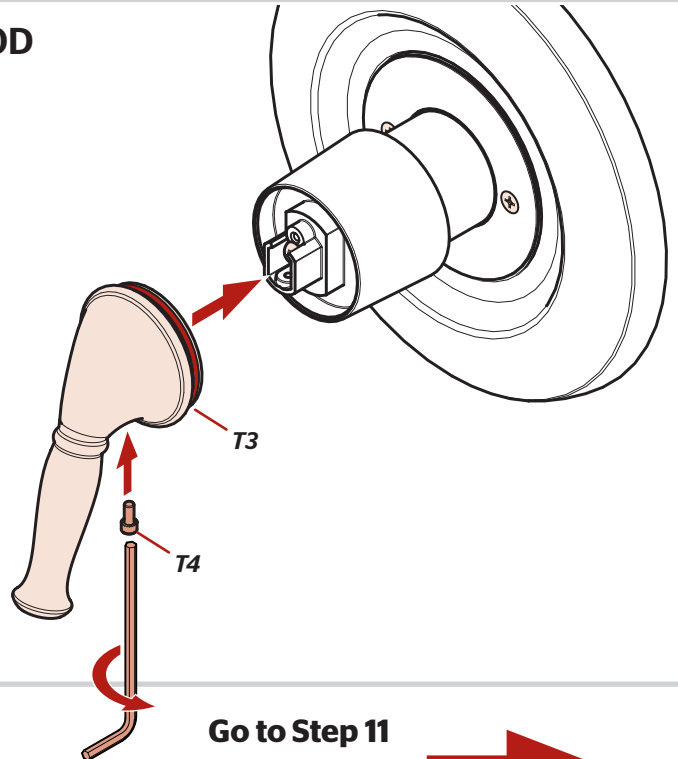

Go to Step 11
Vaya al paso 11
Passez à l'étape 11



Remove existing tub spout (check under spout for screw to remove). If there is no set screw, rotate spout counter clockwise to remove. Make sure all items are free of debris and clean all mounting surfaces.

Quite el canalón existente de la tina (cheque debajo del canalón para que el tornillo quite). Si no hay tornillo de fijación, gire el surtidor contra clockwise para eliminar. Cerciórese de que todos los artículos estén libres de la ruina y limpie todas las superficies de montaje

Enlevez le bec existant de baquet (contrôle sous le bec pour que la vis enlève). S'il n'ya pas de vis de réglage, tournez le bec contre clockwise pour enlever. Assurez-vous que tous les articles sont exempts de débris et nettoyez toutes les surfaces de montage.

11

Identify Tub Spout Plumbing

Identifique la plomería del surtidor de la tina

Identifiez la tuyauterie de bec de baquet

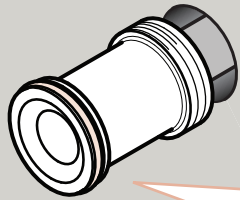

Brass Adapter - Go to Step 12

Instalación de cobre amarillo del adaptador - Vaya al paso 12

Installation en laiton d'adaptateur - Passez à l'étape 12

Make sure that O-ring is in good condition

Asegúrese que el anillo o esté en buenas condiciones

Assurez-vous que l'anneau est en bonne condition

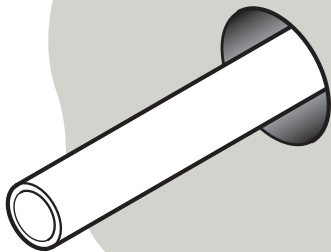

Copper Pipe - Go to Step 13

Pipa de cobre recta - Vaya al paso 13

Pipe de cuivre droite - Passez à l'étape 13

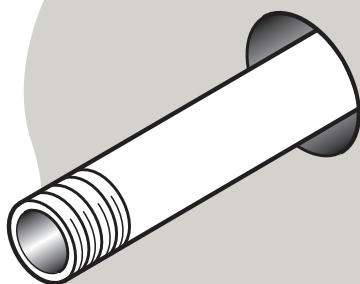

Threaded Pipe - Go to Step 14

Pipa roscada hierro - Vaya al paso 14

Pipe filetée par fer - Passez à l'étape 14



PTFE plumber's tape
Cinta para plomería PTFE
Ruban PTFE de plombier



Caulking or Sealant
Calafateo o sellante
Calfeutrage ou mastic



Supplied Hex Wrench
Proveído Llave hexagonal
Fourni Clé hexagonale

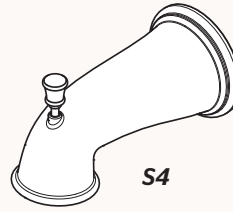

S4

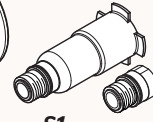

S1

S2

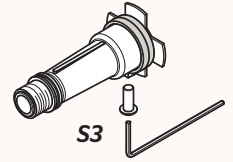

S3

12 Spout Installation: Brass Adapter

Instalación del surtidor: Adaptador de bronce

Installation de bec: Adapteur en laiton

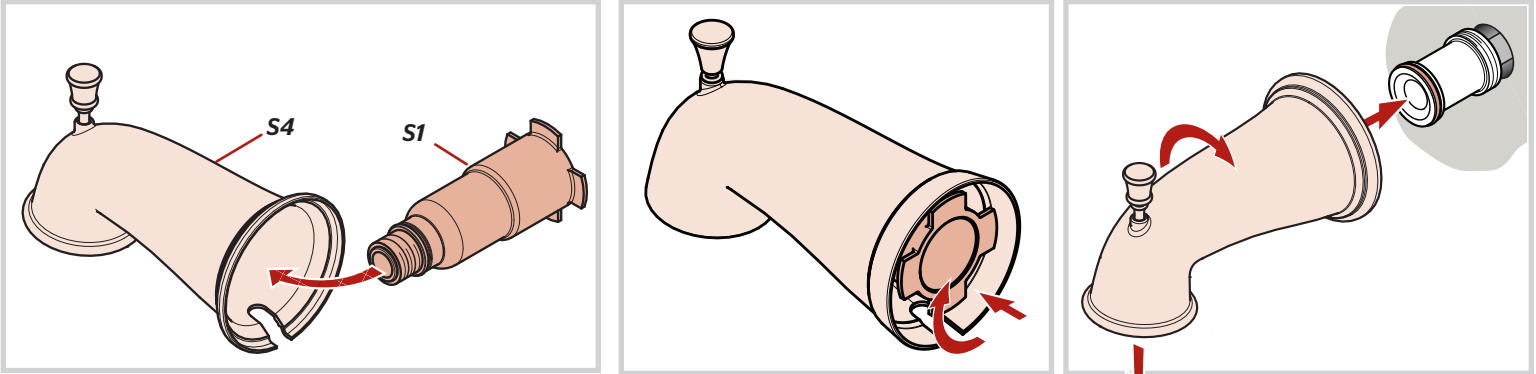

13 Spout Installation: Copper Pipe

Instalación del canalón: Pipa de cobre

Installation de bec: Pipe de cuivre

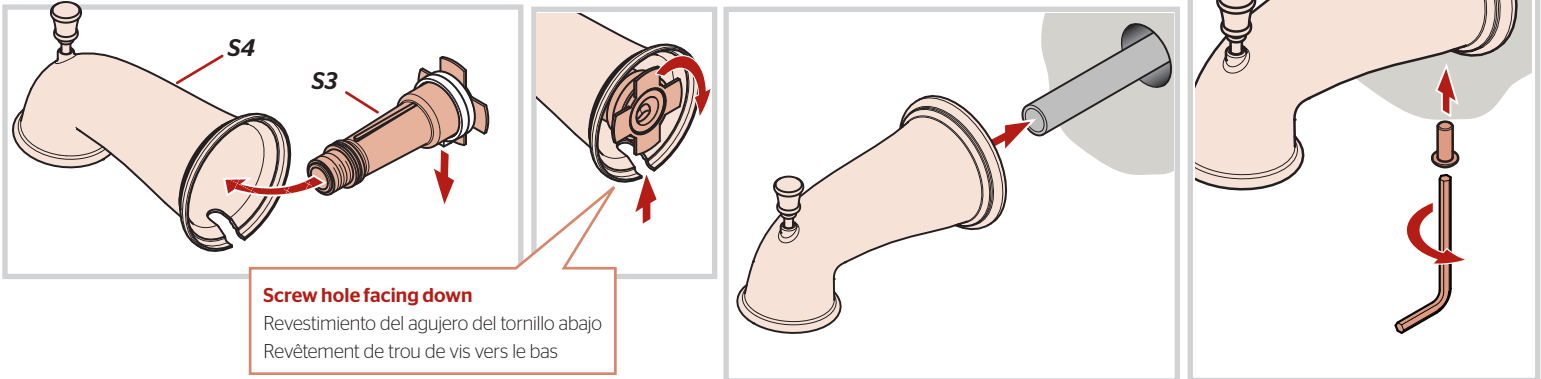

14 Spout Installation: Threaded Pipe

Instalación del canalón: Pipa roscada

Installation de bec: Pipe filetée

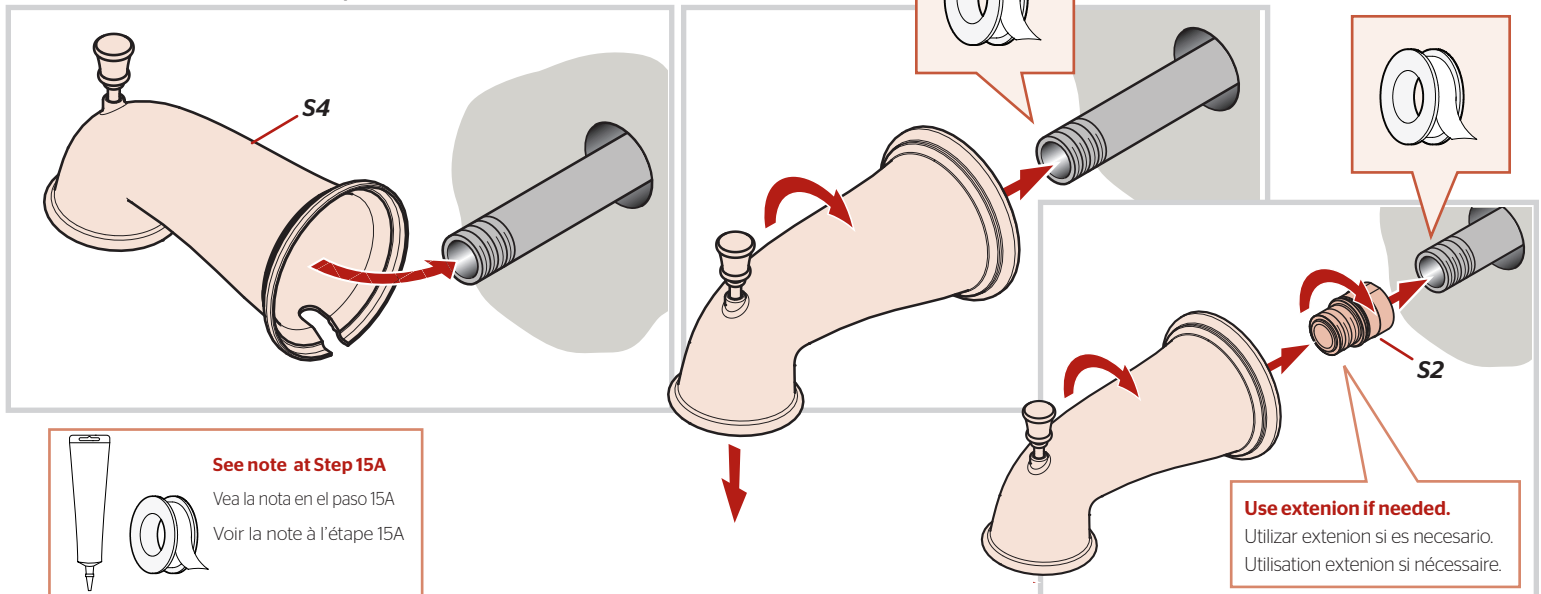

15 Installing Shower Arm and Shower Head

Instalación del brazo de ducha y cabeza de ducha

Installation du bras de douche et tête de douche

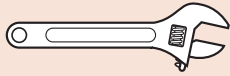

Adjustable Wrench
Llave ajustable
Clé à mollette



PTFE plumber's tape
Cinta para plomería PTFE
Ruban PTFE de plombier

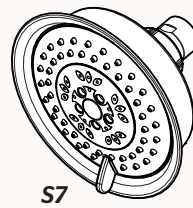

S7

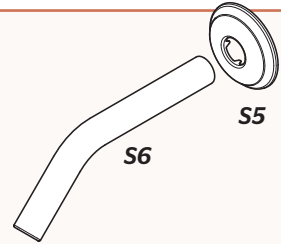

S6

S5

15A

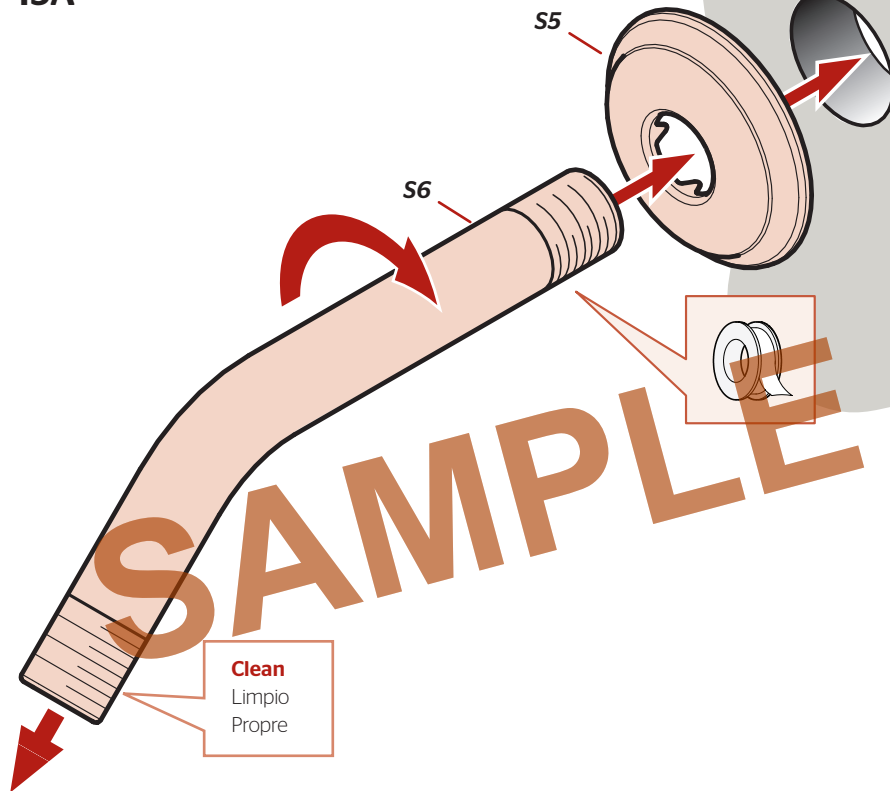

Clean
Limpio
Propre

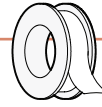

Apply PTFE Plumber's Tape or Thread Sealant to all threaded fittings according to manufacturer's instructions.

Aplique cinta para plomería de PTFE o sello para roscas en todos los adaptadores roscados de acuerdo con las instrucciones del fabricante.

Appliquez du ruban de plomberie PTFE ou du mastic pour filetage à tous les raccords filetés conformément aux instructions du fabricant.



Apply Caulking or Sealant to gaps if needed according to manufacturer's instructions.

Aplicar calafateo o sellante brechas si es necesario de acuerdo con las instrucciones del fabricante.

Appliquer calfeutrage ou mastic à combler les lacunes si nécessaire selon les instructions du fabricant.

15B

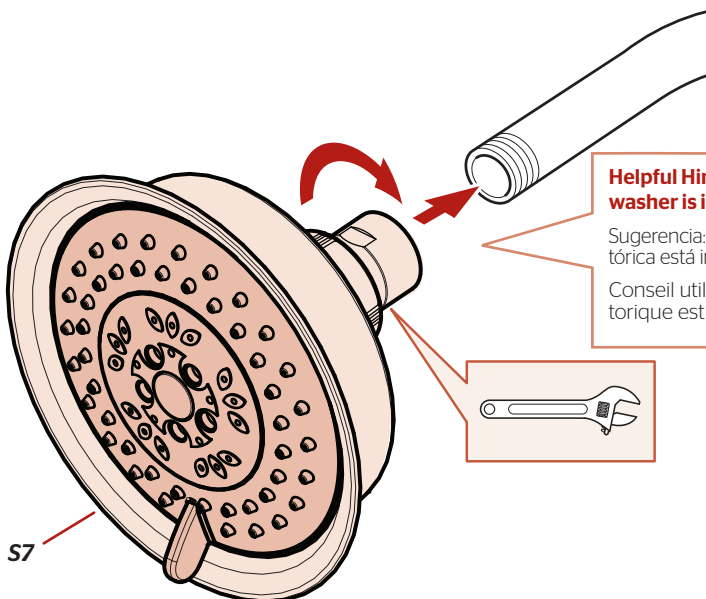

Helpful Hint: Make sure rubber washer is installed

Sugerencia: Asegúrese de que la junta tórica está instalado

Conseil utile: Assurez-vous que le joint torique est installé

For Additional Installation Help:

Para la instalación adicionales de ayuda:
Pour aider à l'installation supplémentaires:

PfISTER

**1-800-PFAUCET (732-8238)
pfisterfaucets.com**