

Square Modern™ GT533-MDS

Pot Filler Faucet
Grifo Rellenador de Ollas
Robinet de Remplissage de Pot

Quick Installation Guide Guía de Instalación Rápida Guide d'Installation Rapide

Installation Support • Soporte de Instalación • Support d'Installation

Personal Assistance, Product Specs, & "How-to" Questions:

Asistencia personal, especificaciones del producto y preguntas sobre "cómo hacerlo":

Aide personnelle, spécifications du produit et questions « pratico-pratiques » :

1-800-PFAUCET (732-8238)

pfisterfaucets.com/support

Installation Videos Available
Videos de instalación a disposición
Vidéos d'installation disponibles



pfisterfaucets.com/videos



WARNING / ADVERTENCIA / AVERTISSEMENT

To reduce the risk of injury or property damage, read all instructions before installing product. Wear safety goggles. Product must be installed in accordance with all state & local plumbing & building codes. Call a professional if you are uncertain about installing this product.

Para disminuir el riesgo de lesiones o daños a la propiedad, lea todas las instrucciones antes de instalar el producto. Utilice gafas de seguridad. El producto deberá instalarse de acuerdo con la normativa de plomería y construcción estatal y local. Llame a un profesional si no está seguro sobre cómo instalar este producto.

Pour réduire le risque de blessures ou de dommages, lire toutes les instructions avant d'installer le produit. Portez des lunettes de sécurité. Il faut installer le produit en respectant tous les codes de construction et de plomberie locaux et d'état. Appelez un professionnel si vous n'êtes pas certain de la façon d'installer ce produit.

Required Tools

Herramientas necesarias
Outils nécessaires

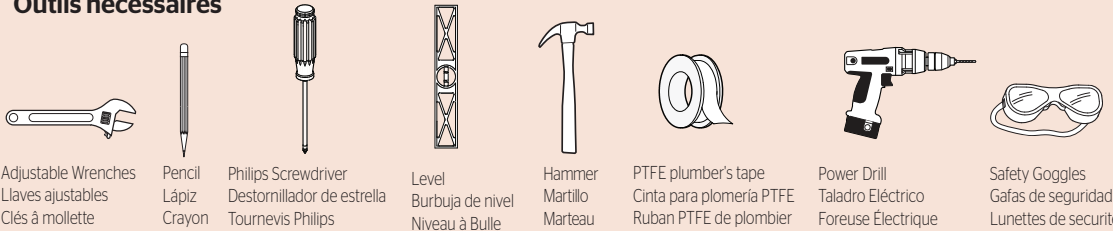

Adjustable Wrenches
Llaves ajustables
Clés à mollette

Pencil
Lápiz
Crayon

Philips Screwdriver
Destornillador de estrella
Tournevis Philips

Level
Burbuja de nivel
Niveau à Bulle

Hammer
Martillo
Marteau

PTFE plumber's tape
Cinta para plomería PTFE
Ruban PTFE de plombier

Power Drill
Taladro Eléctrico
Foreuse Électrique

Safety Goggles
Gafas de seguridad
Lunettes de sécurité

Additional Helpful Tools Otras herramientas útiles Outils supplémentaires utiles

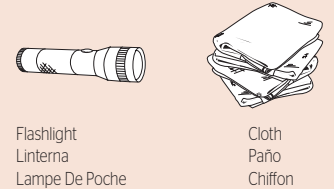

Flashlight
Linterna
Lampe De Poche

Cloth
Paño
Chiffon

Parts in the Box

Piezas en la caja
Pièces dans la boîte

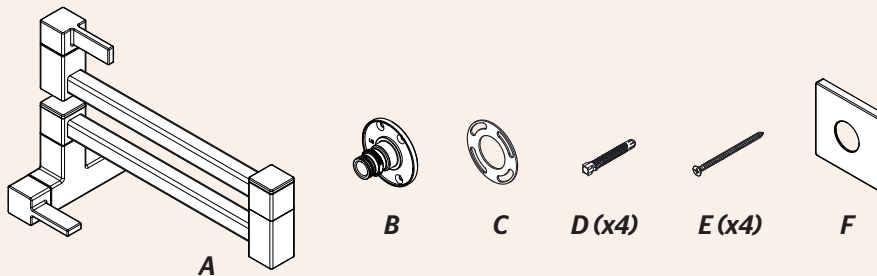

Hex Wrench
Llave hexagonal
Clé hexagonale



Aerator Tool
Herramienta para el aireador
Outil d'aérateur

‡ Store in a safe place
‡ Almacenar en un lugar seguro
‡ Conserver dans un endroit sûr

1 Turn Off Water Supply • Cierre el suministro de agua • Couper l'alimentation en eau



Locate water supply and shut off the water supply valve.

Localice el suministro de agua y cierre la válvula de suministro de agua.

Localisez l'approvisionnement en eau et fermez le robinet d'alimentation en eau.

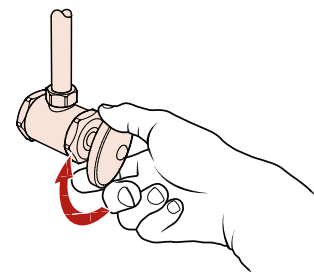

2

Option 1-Drywall/Tile: Mount Spout Holder

Opción 1-Paneles de yeso/azulejos: Monte el soporte del grifo

Option 1-Cloison sèche/carrelage: Monter le support du robinet

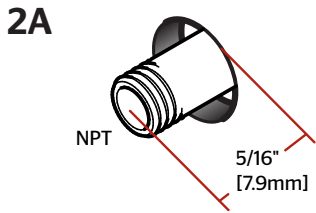
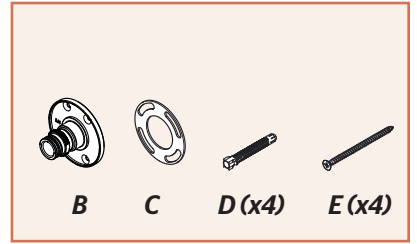

Ensure pipe is level
Asegúrese tubería esté nivelada
Assurez-vous tuyau est de niveau

Use Holder (B) as hole template
Utilice el sostenedor para la plantilla del agujero
Employez le support pour le calibre de trou

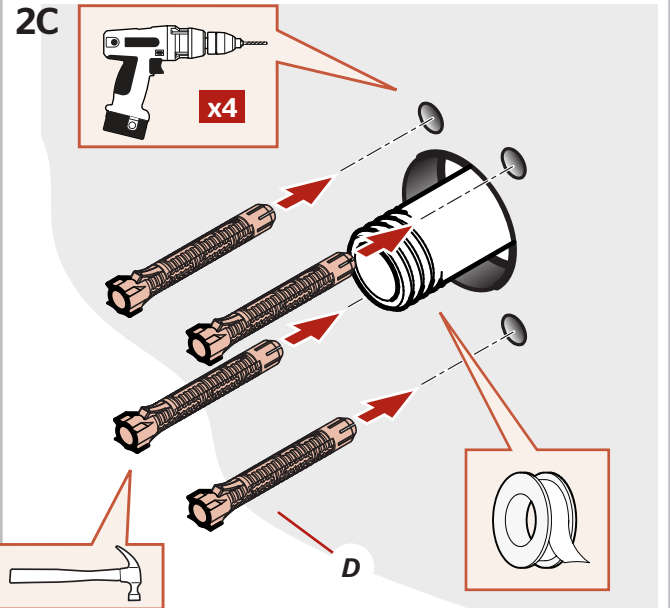
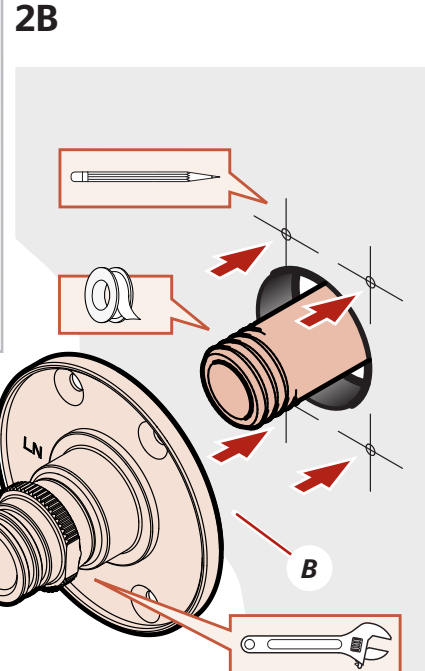

Apply PTFE Plumber's Tape or Thread Sealant according to manufacturer's instructions.
Coloque cinta PTFE o Sellador de Roscas de acuerdo con las instrucciones del fabricante.
Appliquez PTFE Plombiers bande ou le scellant de filets selon les instructions du fabricant.

Tip • Indicio • Conseil
Use tape to prevent gasket (C) from moving
Utilice cinta adhesiva para evitar que el sello (C) se mueva
Utilisez du ruban pour empêcher le joint (C) de bouger

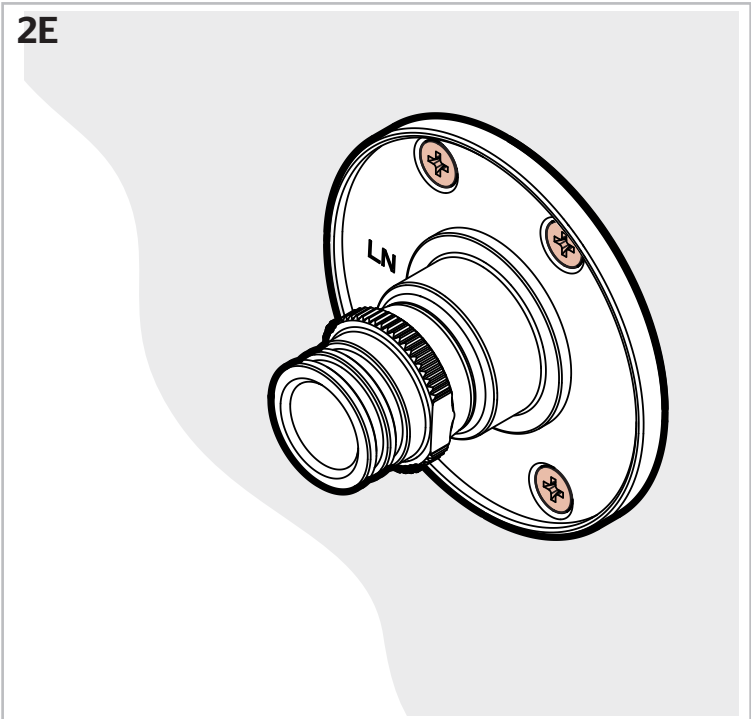
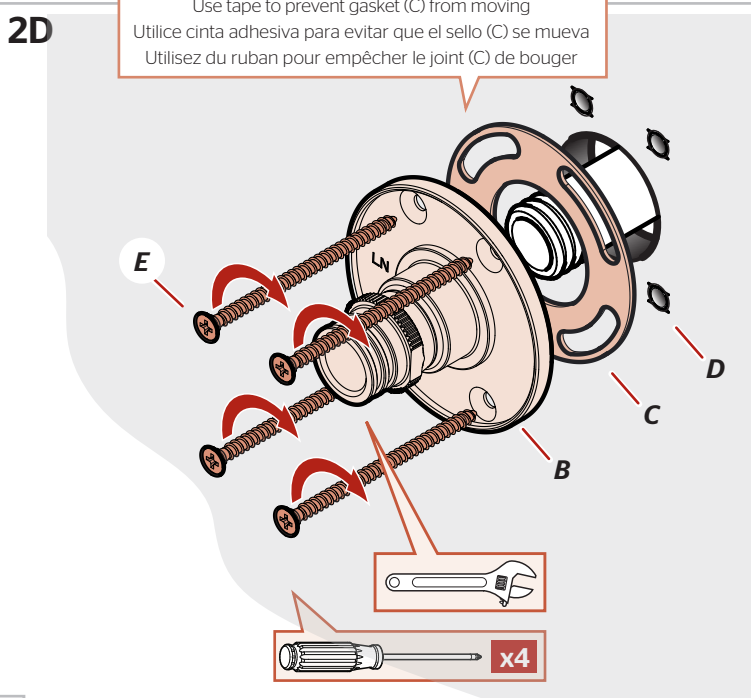

2 Option 2-Wood: Mount Spout Holder

Opción 2-Madera: Monte el soporte del grifo

Option 2-Bois: Monter le support du robinet



Hammer
Martillo
Marteau



Power Drill
Taladro Eléctrico
Foreuse Électrique



Pencil
Lápiz
Crayon



Philips Screwdriver
Destornillador de estrella
Tournevis Philips



Safety Goggles
Gafas de seguridad
Lunettes de sécurité



Adjustable Wrenches
Llaves ajustables
Clés à molette



PTFE plumber's tape
Cinta para plomería PTFE
Ruban PTFE de plombier



B



C



E (x4)

2A

Install onto Stringer

Instalar en Stringer
Installer dans Stringer



2B

Use Holder (B) as hole template

Utilice el sostenedor para la plantilla del agujero

Employez le support pour le calibre de trou

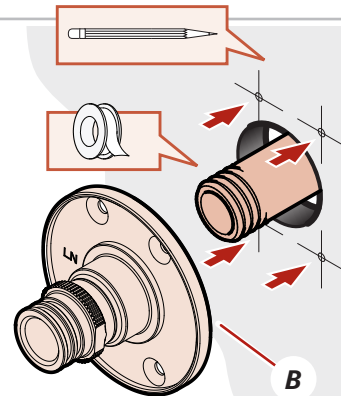

2C

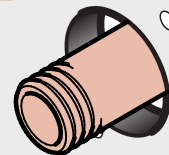

2D

Tip • Indicio • Conseil

Use tape to prevent gasket (C) from moving
Utilice cinta adhesiva para evitar que el sello (C) se mueva
Utilisez du ruban pour empêcher le joint (C) de bouger

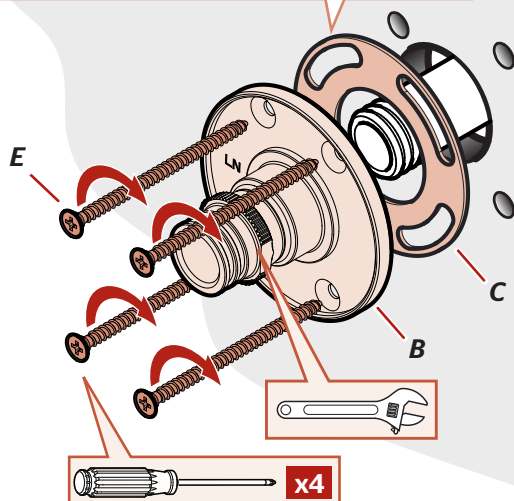

2E

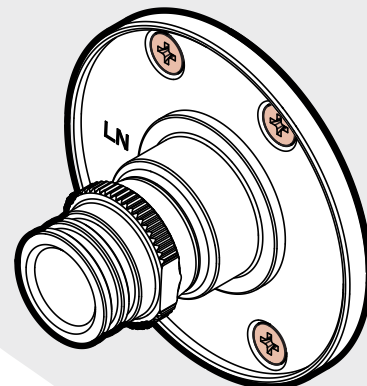

3

Attach Spout Coloque el grifo Fixez le robinet



Hex Wrench
Llave hexagonal
Clé hexagonale



Level
Burbuja de nivel
Niveau à Bulle

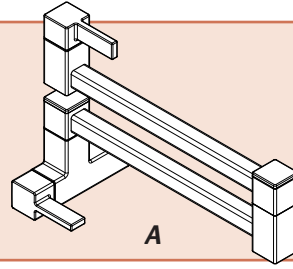

A

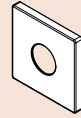

F

3A

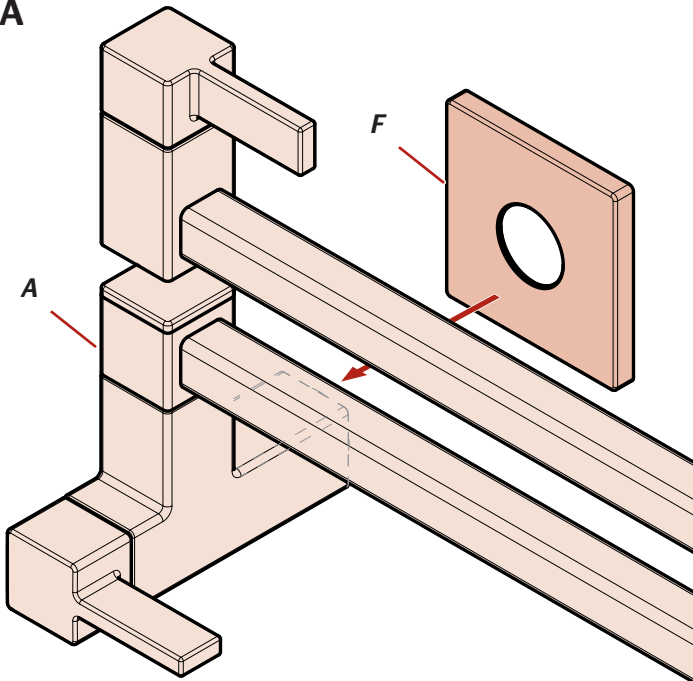

3B

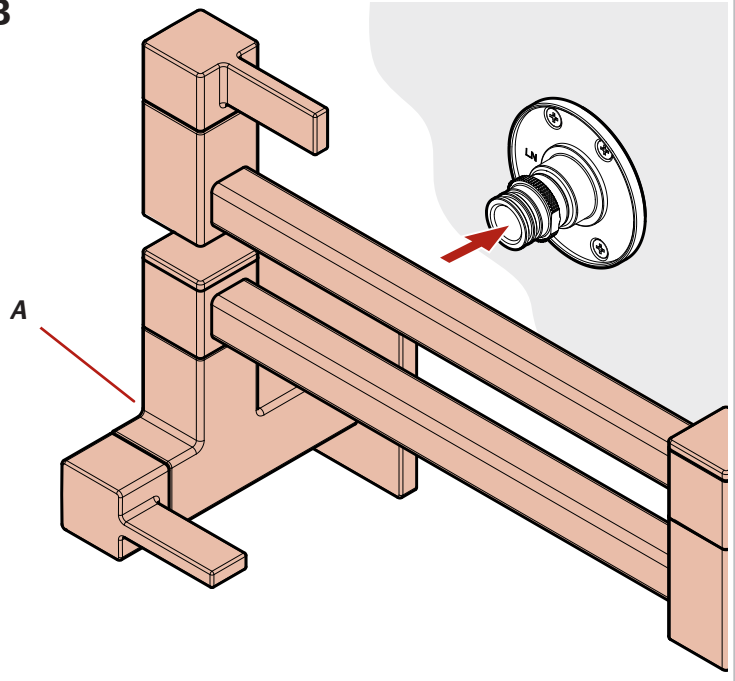

3C

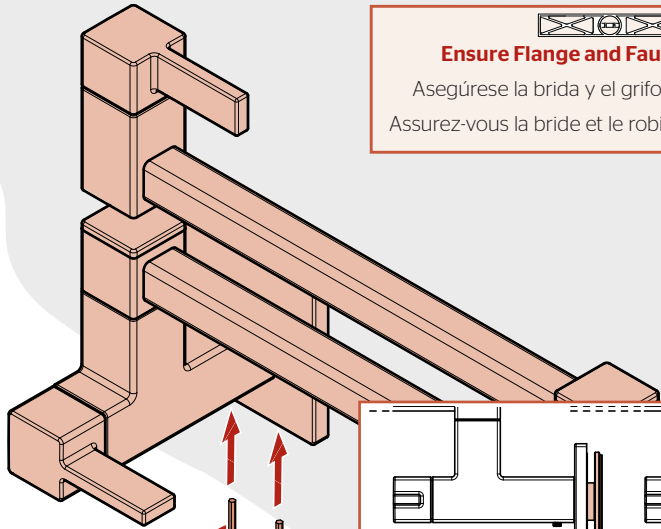

Ensure flange and faucet are level

Asegúrese la brida y el grifo estén nivelados
Assurez-vous la bride et le robinet sont de niveau

Tighten both set screws

Apriete ambos tornillos
Serrez les deux vis

2.5MM Hex Wrench
Llave hexagonal de 2.5MM
Clé hexagonale de 2.5MM

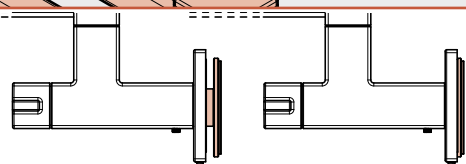

Ensure the spout is flush to mounting anchor before fully tightening.

Asegúrese de que el pico esté plano contra el anclaje de montaje antes de apretarlo completamente.
Assurez-vous que le bec est à plat contre l'ancrage de montage avant de serrer complètement.



Ensure both valves are in closed position before proceeding.

Asegúrese de que ambas válvulas estén en posición cerrada antes de continuar.

Assurez-vous que les deux vannes sont en position fermée avant de continuer.

Closed
Cerrado
Fermé

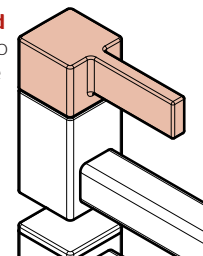

Closed
Cerrado
Fermé

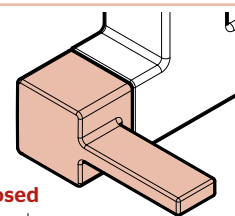

4 Turn On Water Supply & Check for Leaks

Active el suministro de agua y verifique si hay fugas

Ouvrez l'alimentation en eau et vérifiez les fuites

4A Remove Aerator

Retire el aereador
Retirez l'aérateur

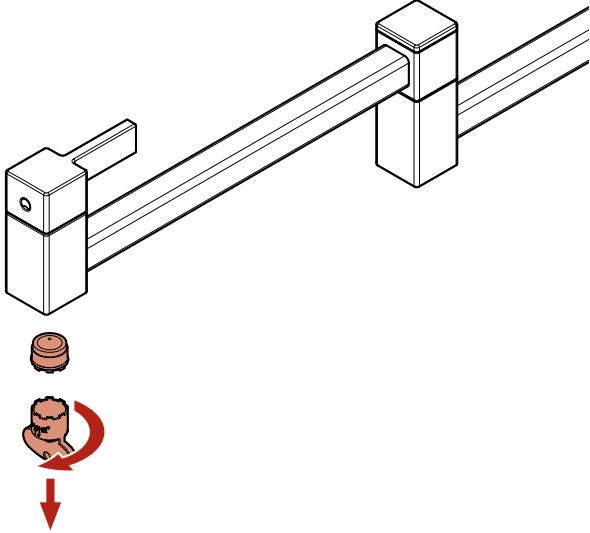

4B

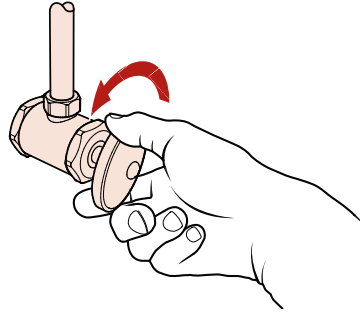

Turn on the water supply valve.

Abra la válvula de suministro de agua.
Ouvrez la vanne d'alimentation en eau.

4C Open main valve

Abra la válvula principal
Ouvrir le robinet principal

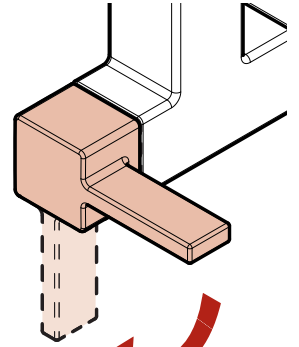

Open
Abierta
Ouvverte

4D

Slowly open end valve.

Abra lentamente
Ouvrez lentement

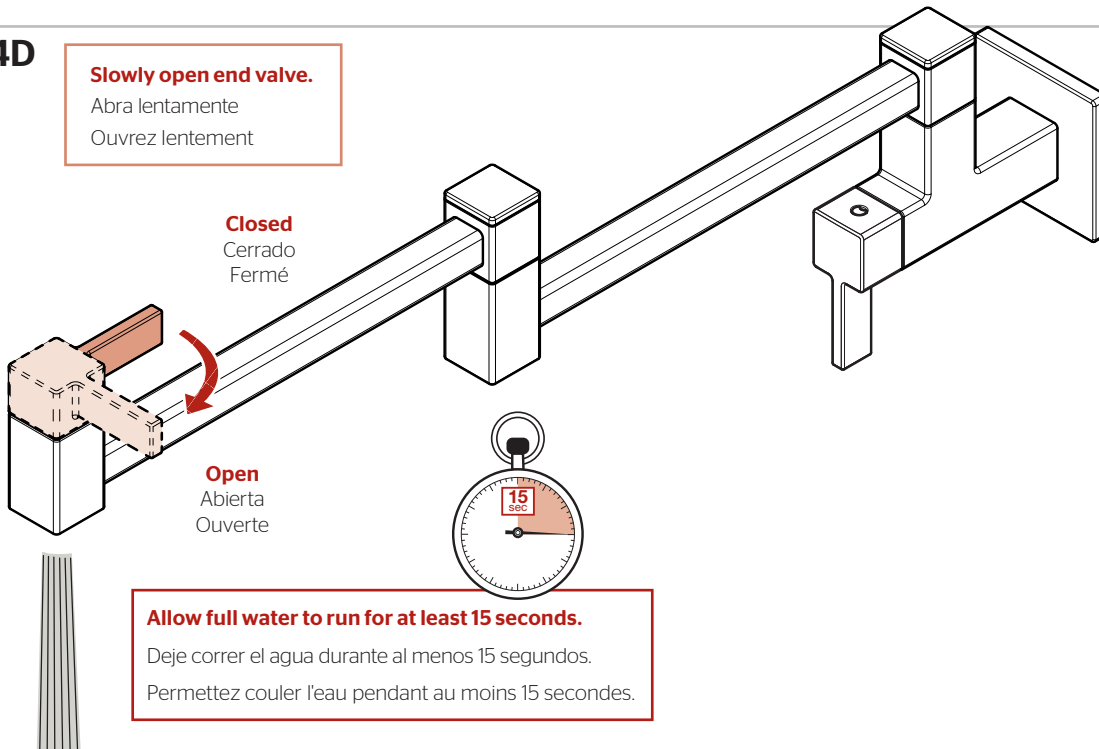

Allow full water to run for at least 15 seconds.

Deje correr el agua durante al menos 15 segundos.
Permettez couler l'eau pendant au moins 15 secondes.

Reinstall Aerator
Reinstale el aereador
Réinstallez l'aérateur

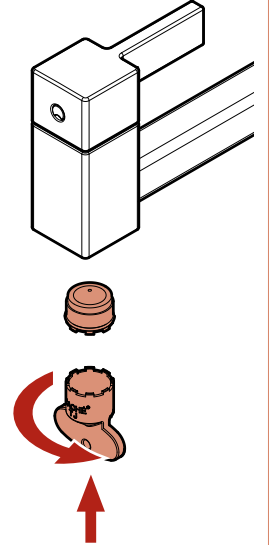

5

Faucet Functions Funciones del Grifo Fonctions de Robinet

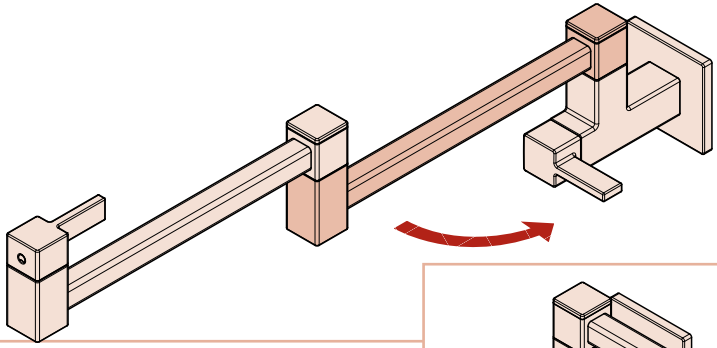

Storing Faucet
Guardar el Grifo
Rangement le Robinet

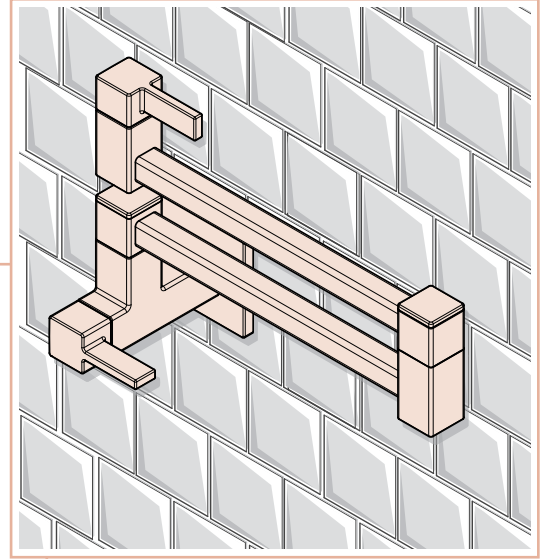
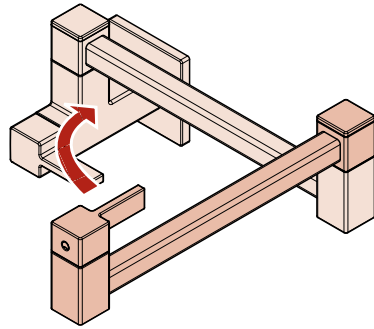

For Additional Installation Help:
Para la instalación adicionales de ayuda:
Pour aider à l'installation supplémentaires:

Pfister®

1-800-PFAUCET (732-8238)
pfisterfaucets.com