



Installation Support • Soporte de instalación • Support d'installation

Personal Assistance, Product Specs, & "How-to" Questions:

Asistencia personal, especificaciones del producto y preguntas sobre "cómo hacerlo":

Aide personnelle, spécifications du produit et questions « pratique-pratiques » :

1-800-PFAUCET (732-8238)

pfisterfaucets.com/support

Installation Videos Available
Videos de instalación a disposición
Vidéos d'installation disponibles



pfisterfaucets.com/videos



WARNING / ADVERTENCIA / AVERTISSEMENT

To reduce the risk of injury or property damage, read all instructions before installing product. Wear safety goggles. Product must be installed in accordance with all state & local plumbing & building codes. This product may take two people to install. Call a professional if you are uncertain about installing this product.

Para disminuir el riesgo de lesiones o daños a la propiedad, lea todas las instrucciones antes de instalar el producto. Utilice gafas de seguridad. El producto deberá instalarse de acuerdo con la normativa de plomería y construcción estatal y local. Este producto se puede tomar a dos personas para instalar. Llame a un profesional si no está seguro sobre cómo instalar este producto.

Pour réduire le risque de blessures ou de dommages, lire toutes les instructions avant d'installer le produit. Porter des lunettes de sécurité. Le produit doit être installé en conformité avec tous les codes de construction et de plomberie locaux et de l'état. Ce produit peut prendre deux personnes pour installer. Appelez un professionnel si vous n'êtes pas certain de la façon d'installer ce produit.

Required Tools

Herramientas necesarias
Outils nécessaires

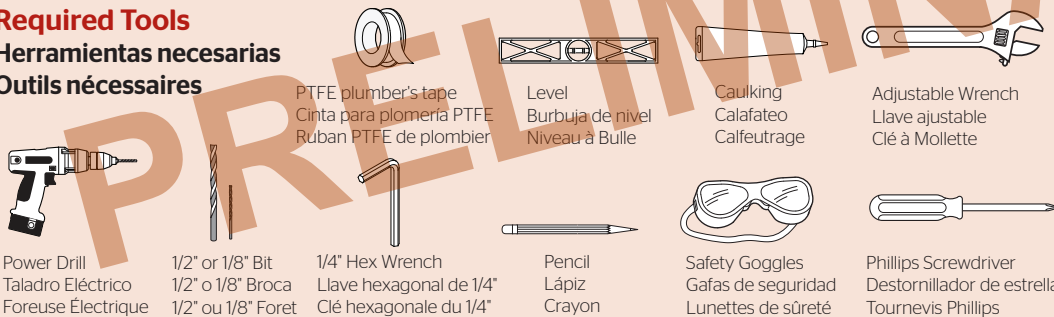

Additional Helpful Tools
Otras herramientas útiles
Outils supplémentaires utiles

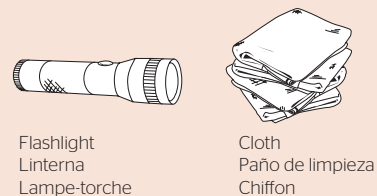

Parts in the Box • Piezas en la caja • Pièces dans la boîte

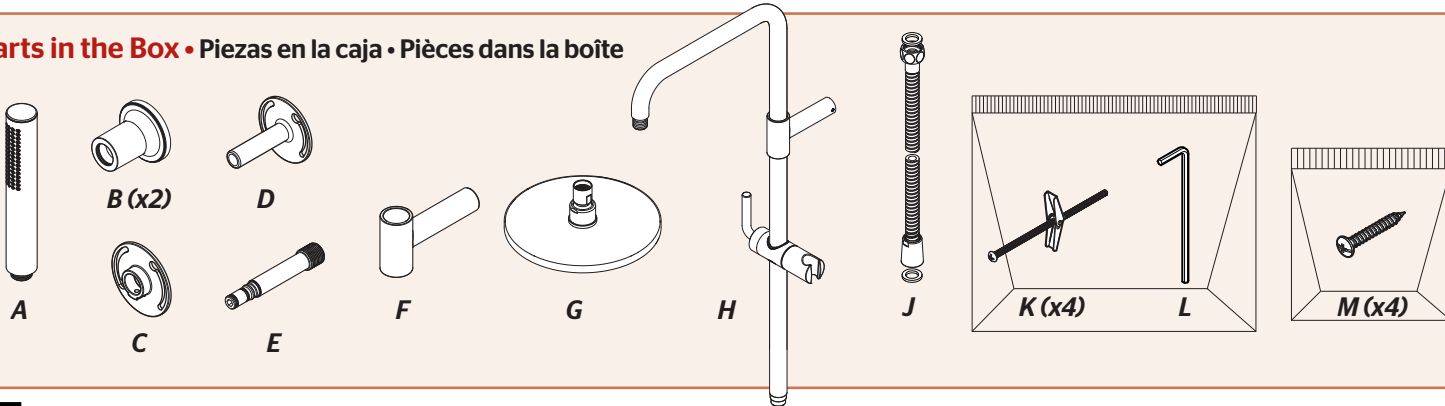

1 Turn Off Water Supply • Cierre el suministro de agua • Couper l'alimentation en eau



Locate water supply inlets and shut off the water supply valves. These are usually found near the water meter. If you are replacing an existing unit, remove the old unit and clean the mounting surface thoroughly.

Localice las entradas de suministro de agua y cierre las válvulas de suministro de agua. Estos se encuentran generalmente cerca del medidor de agua. Si está reemplazando una unidad existente, retire la unidad antigua y limpie a fondo la superficie de montaje.

Localisez les entrées d'alimentation en eau et fermez les vannes d'alimentation en eau. Ceux-ci se trouvent généralement près du compteur d'eau. Si vous remplacez une unité existante, retirez l'ancienne unité et nettoyez soigneusement la surface de montage.

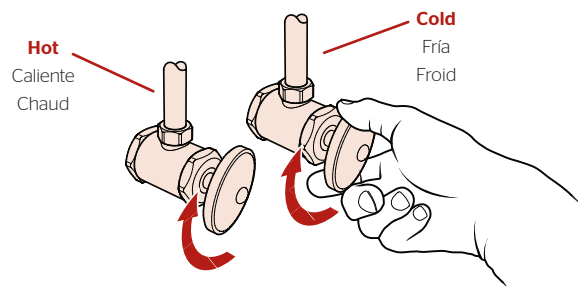

2

Prepare Water Connection Prepare la conexión de agua Préparer le raccordement à l'eau



PTFE plumber's tape
Cinta para plomería PTFE
Ruban PTFE de plombier



1/4" Hex Wrench
Llave hexagonal de 1/4"
Clé hexagonale du 1/4"



Pencil
Lápiz
Crayon



C

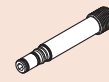

E

2A

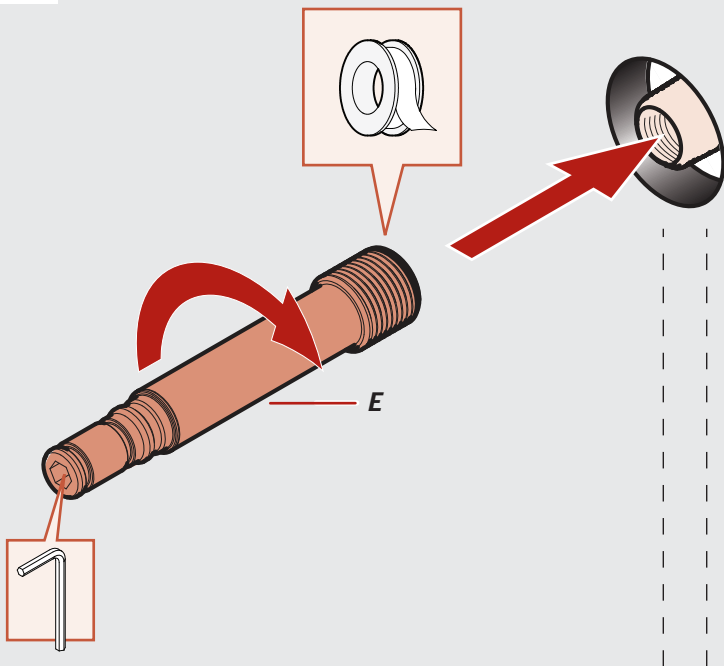

2C

Trace flange and mark 2 spots for screws.
Trazar la brida y marcar 2 puntos para los tornillos.
Tracer la bride et marquer 2 points pour les vis.

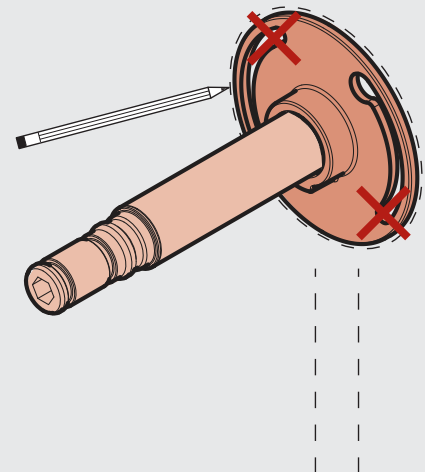

Be careful not to hit pipe that's directly below the fitting.

Tenga cuidado de no golpear la tubería que está directamente debajo de la conexión.
Veillez à ne pas heurter le tuyau directement sous le raccord.

2B

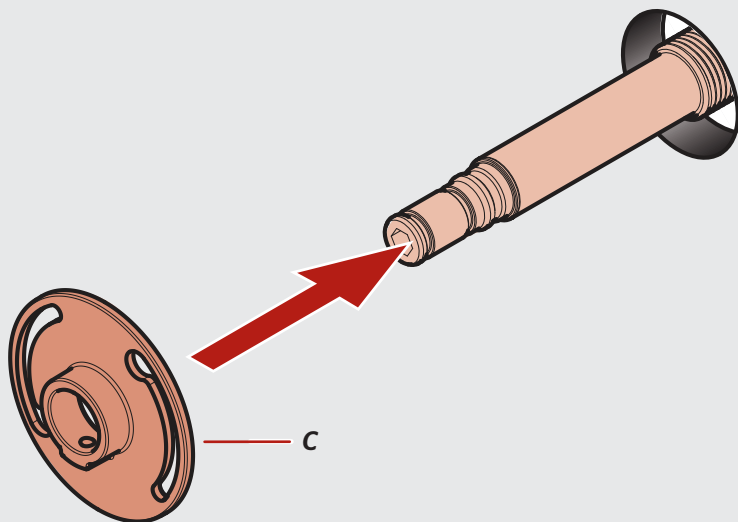

3 Prepare Column and Wall Support

Prepare la columna y soporte de pared

Préparer le support de colonne et de mur



Level
Burbuja de nivel
Niveau à Bulle

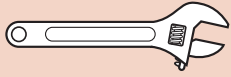

Adjustable Wrench
Llave ajustable
Clé à Mollette



Pencil
Lápiz
Crayon



D

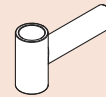

F

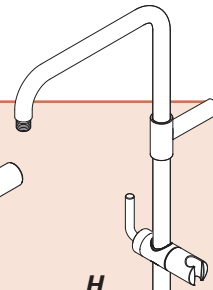

H



L

3A

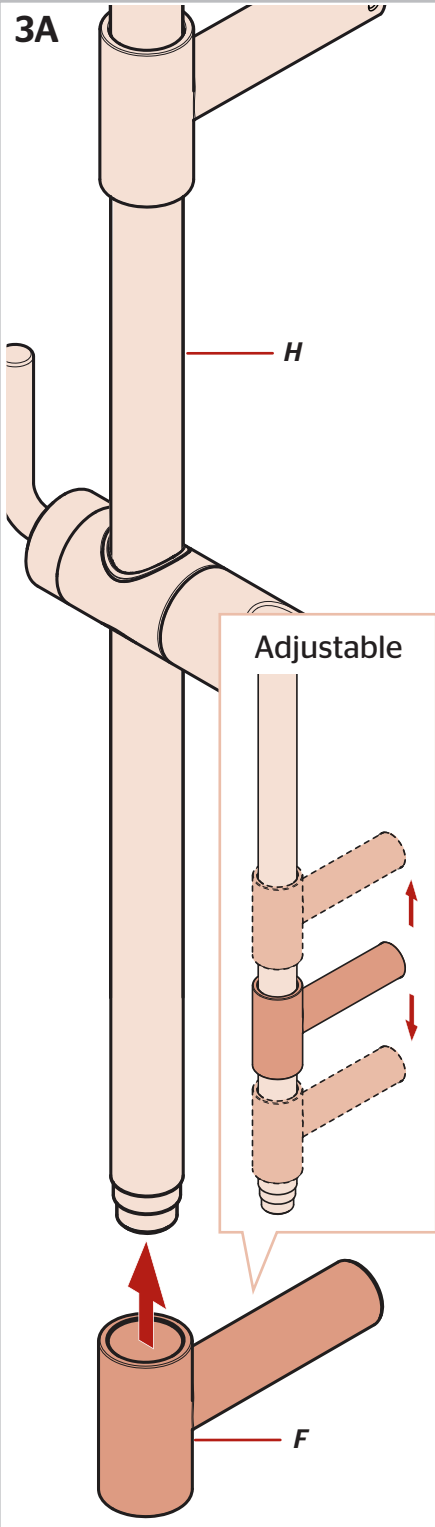

Adjustable

3B

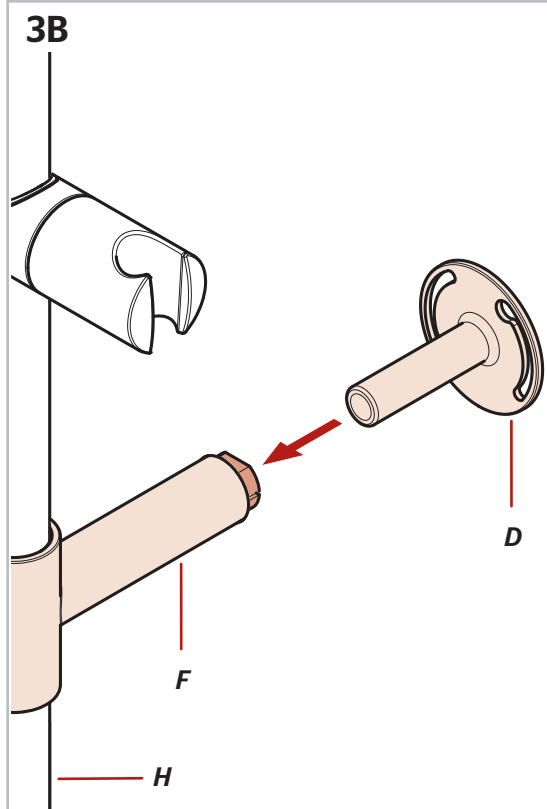

Tighten once desired location is set
Apretar una vez que se establece la ubicación deseada
Serrer une fois que l'emplacement souhaité est défini

3C

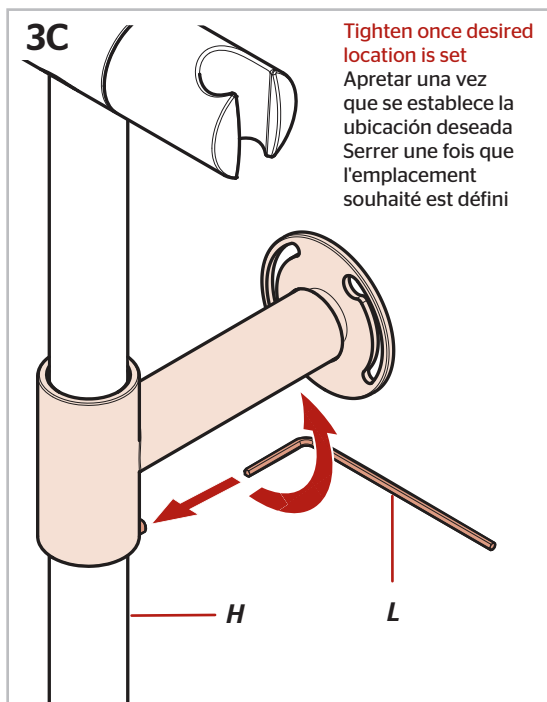

3D

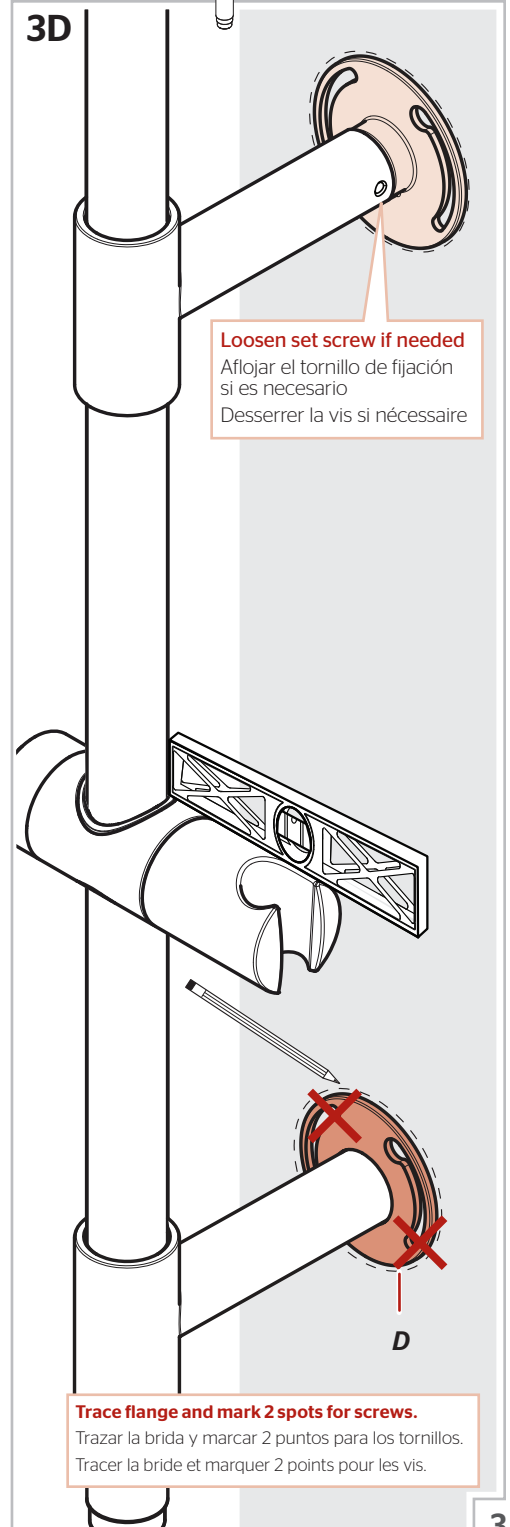

Loosen set screw if needed
Aflojar el tornillo de fijación si es necesario
Desserrer la vis si nécessaire

Trace flange and mark 2 spots for screws.
Trazar la brida y marcar 2 puntos para los tornillos.
Tracer la brida et marquer 2 points pour les vis.

4 Remove Column and Drill Holes

Eliminar la columna y taladrar los agujeros

Retirer la colonne et percer les trous



Power Drill
Taladro Eléctrico
Foreuse Électrique



1/2" or 1/8" Bit
1/2" o 1/8" Broca
1/2" ou 1/8" Foret



C



D

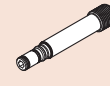

E

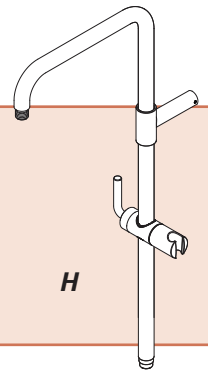

H

4A Remove from wall

Quitar de la pared
Retirer du mur

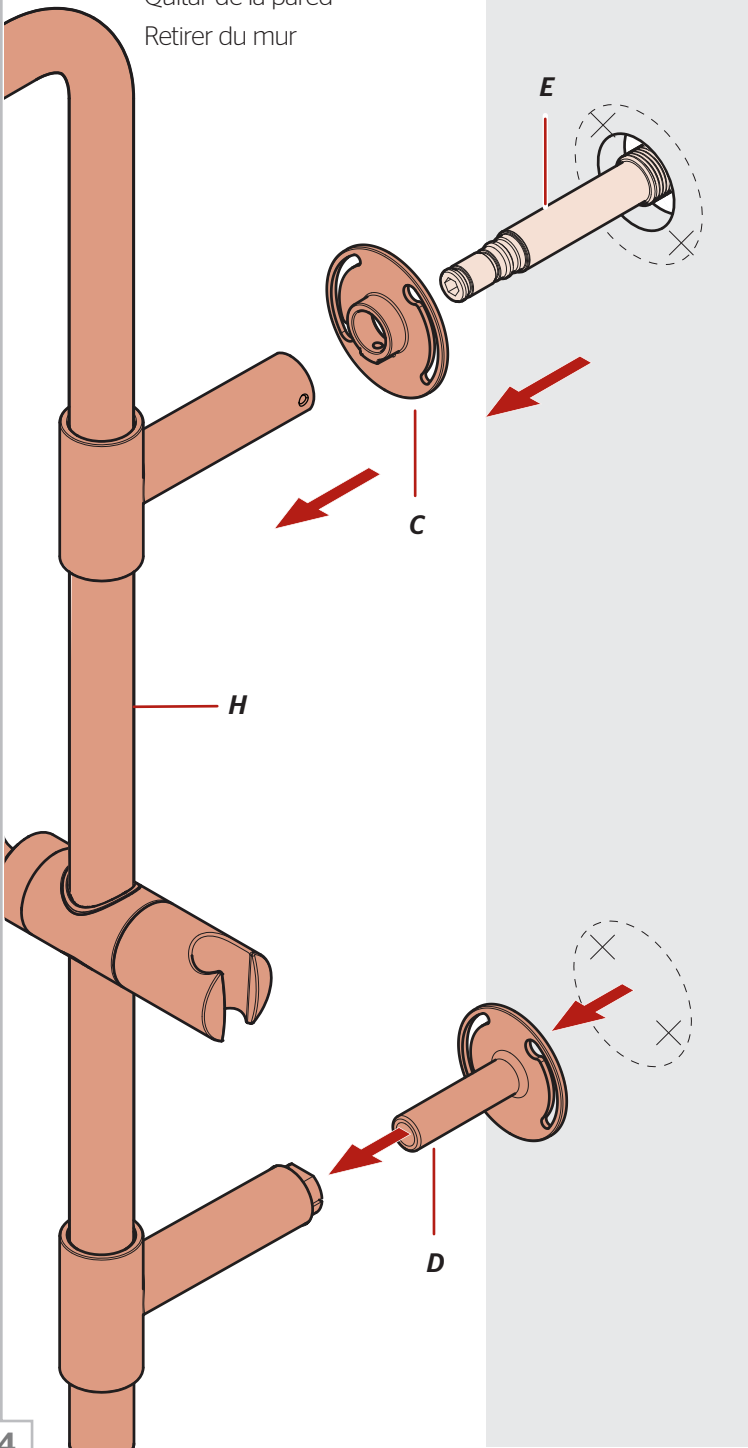

Option 1: DRYWALL Installation

Opción 1: Instalación del PANELES DE YESO
Option 1: Installation dans les CLOISON SÈCHE

4B

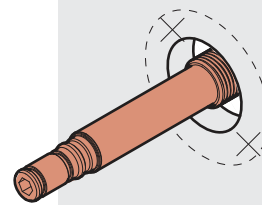

Drill two 1/2" holes.
Taladre dos orificios de 1/2".
Percer deux trous de 1/2 po.



Drill two 1/2" holes.
Taladre dos orificios de 1/2".
Percer deux trous de 1/2 po.

Option 2: STUDS Installation

Opción 2: Instalación del MONTANTES
Option 2: Installation dans les MONTANT

4B

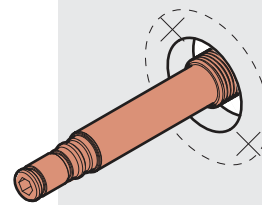

Drill two 1/8" holes.
Taladre dos orificios de 1/8".
Percer deux trous de 1/8 po.



Drill two 1/8" holes.
Taladre dos orificios de 1/8".
Percer deux trous de 1/8 po.

5

Install Shower Column

Instale la columna de ducha

Installer la colonne de douche

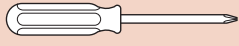

Phillips Screwdriver
Destornillador de estrella
Tournevis Phillips

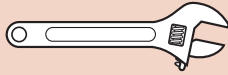

Adjustable Wrench
Llave ajustable
Clé à Mollette



Caulking
Calafateo
Calfeutrage



C



D



H

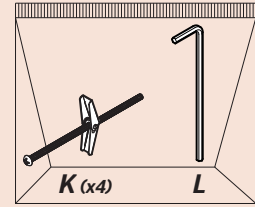

K (x4)

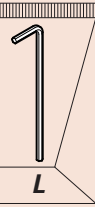

L

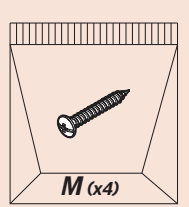

M (x4)

Option 1: DRYWALL Installation

Opción 1: Instalación del **PANELES DE YESO**
Option 1: Installation dans les **CLOISON SÈCHE**

5A



position screws
posición los tornillo
position de vis

5B

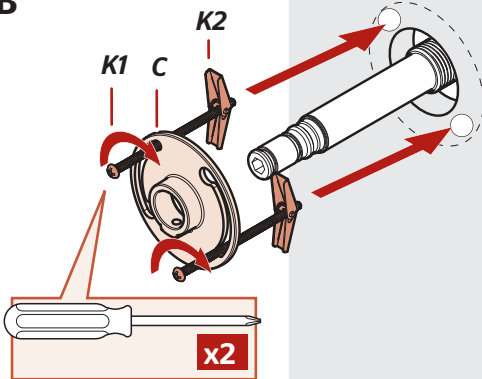

Push in ends to fold.
Empuje en los extremos para doblar.
Enfoncez les extrémités pour les plier.

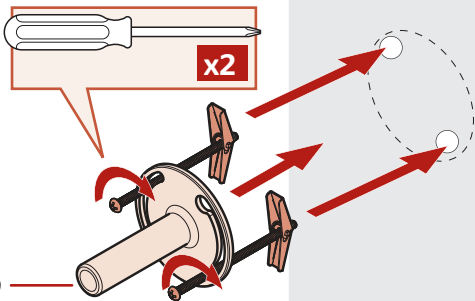

Back of wall
Detrás de la pared
L'arrière du mur

Option 2: STUDS Installation

Opción 2: Instalación del **MONTANTES**
Option 2: Installation dans les **MONTANT**

5A



position screws
posición los tornillo
position de vis

5B

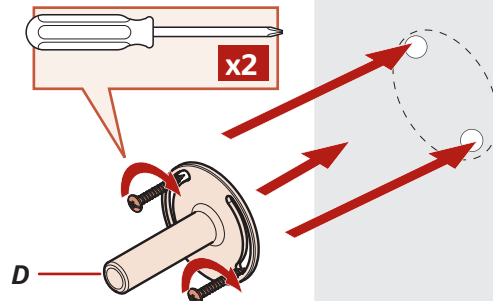
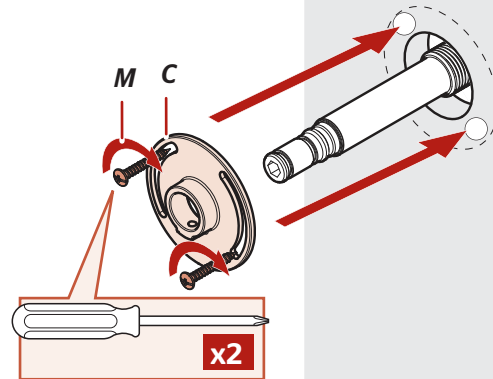

Tip • Indicio • Conseil

Gently pull on flanges to check for stability
Tire suavemente en las bridas para verificar la estabilidad
Tirez doucement sur les brides pour vérifier la stabilité

6 Install Shower Column and Shower Head

Instale la columna de ducha y la cabeza de ducha

Installer la colonne de douche et le pommeau de douche

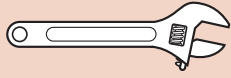

Adjustable Wrench
Llave ajustable
Clé à Mollette



Caulking
Calafateo
Calfeutrage



B (x2)

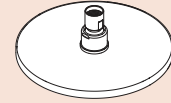

G



L

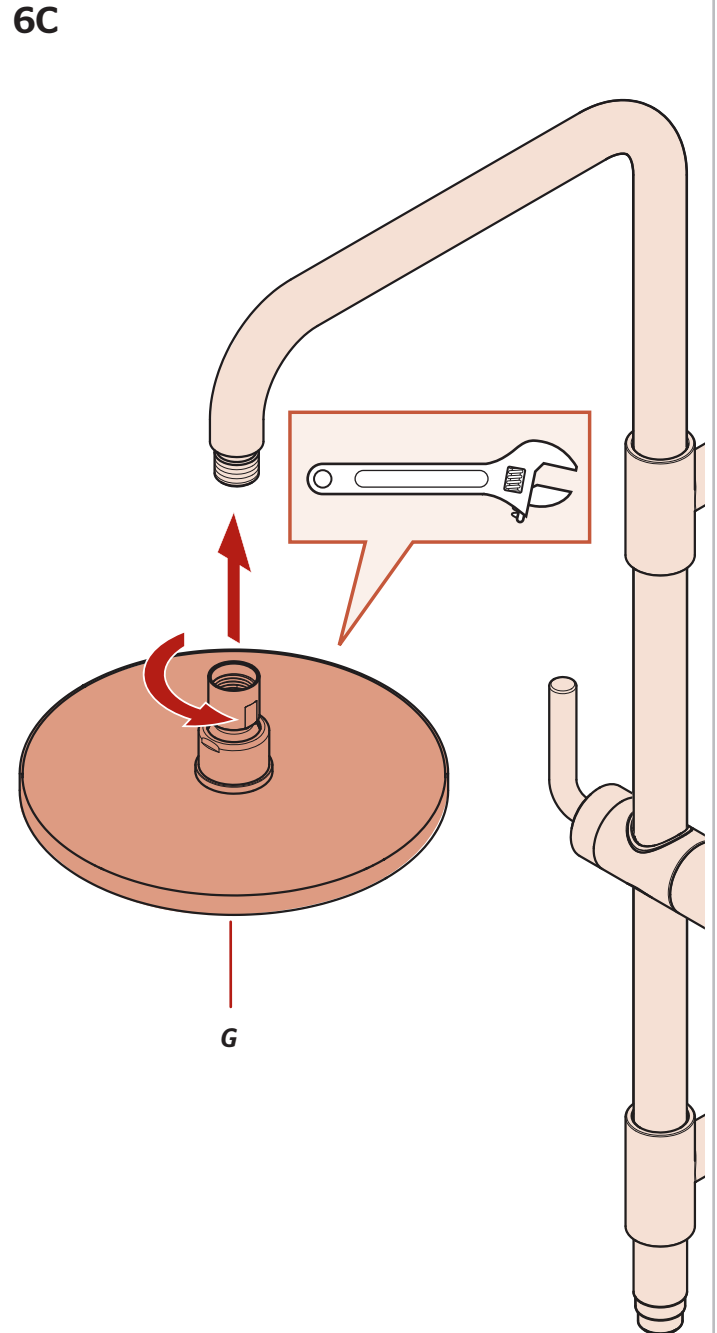
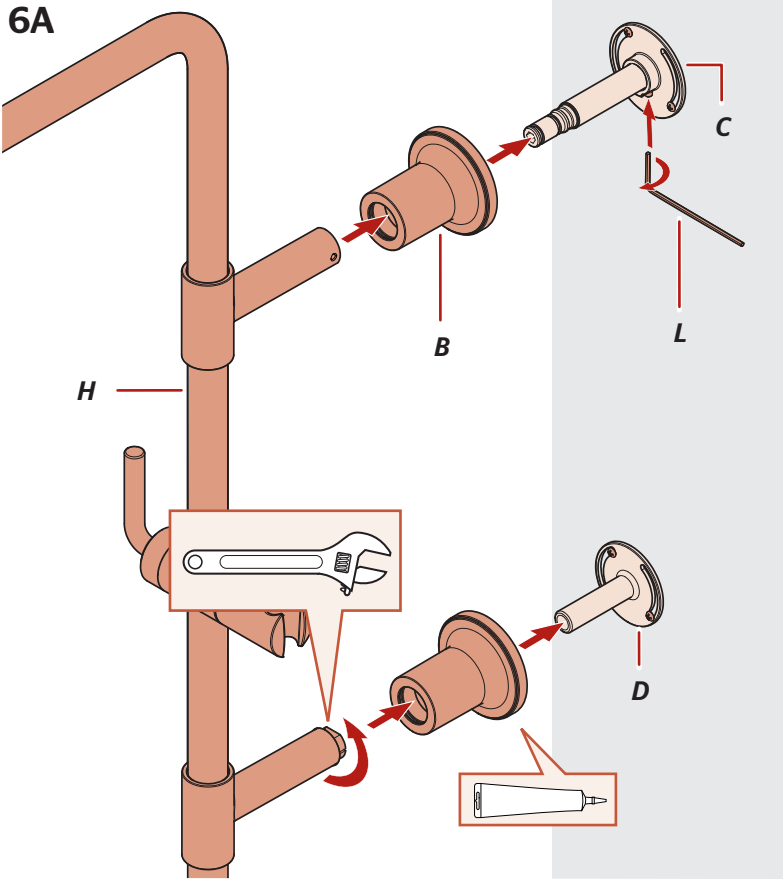

6B Slide up flange to access set screws, then apply silicone.
Deslice hacia arriba la brida para acceder a los tornillos de fijación, luego aplique silicona.
Glissez la bride vers le haut pour accéder aux vis de réglage, puis appliquez du silicone.

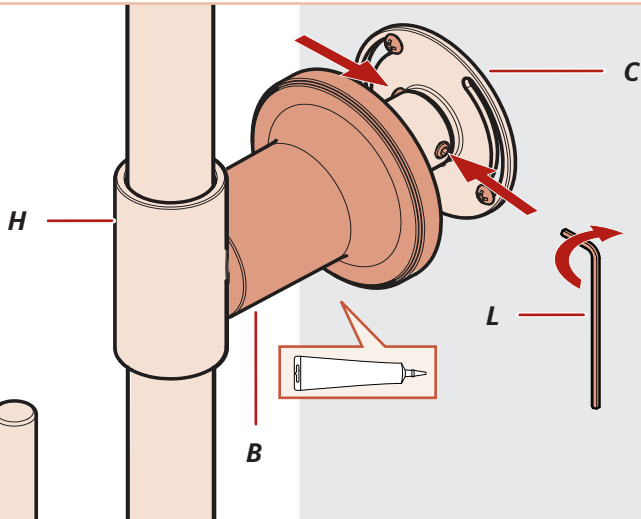

Tip • Indicio • Conseil

Wrap with a towel to protect finish from wrench
Envolver con una toalla para proteger el acabado de la llave.
Envelopper avec une serviette pour protéger le fini de la clé.

7 Install Handheld Instalar ducha de mano Installer une douche à main

No Tools Required for This Step
No se necesitan herramientas para este paso
Pas d'outil nécessaire pour cette étape



A



J

7A

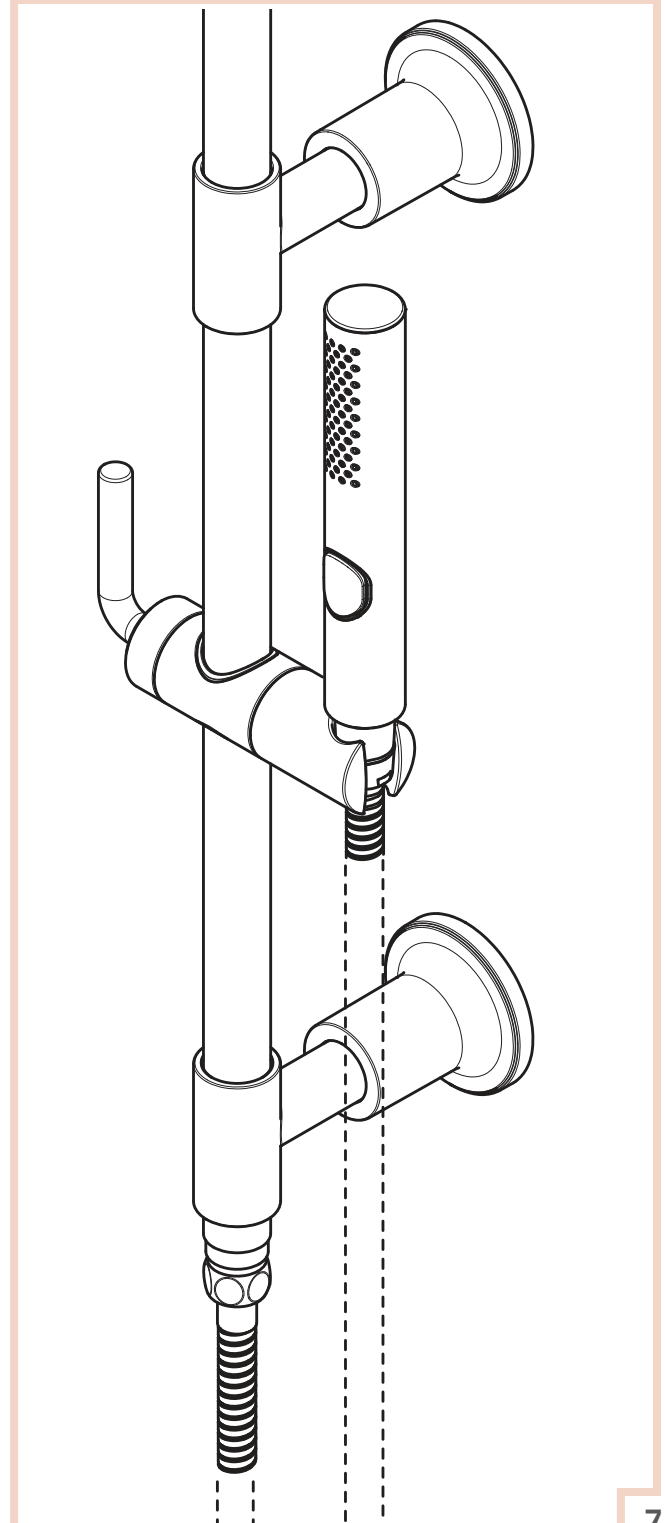
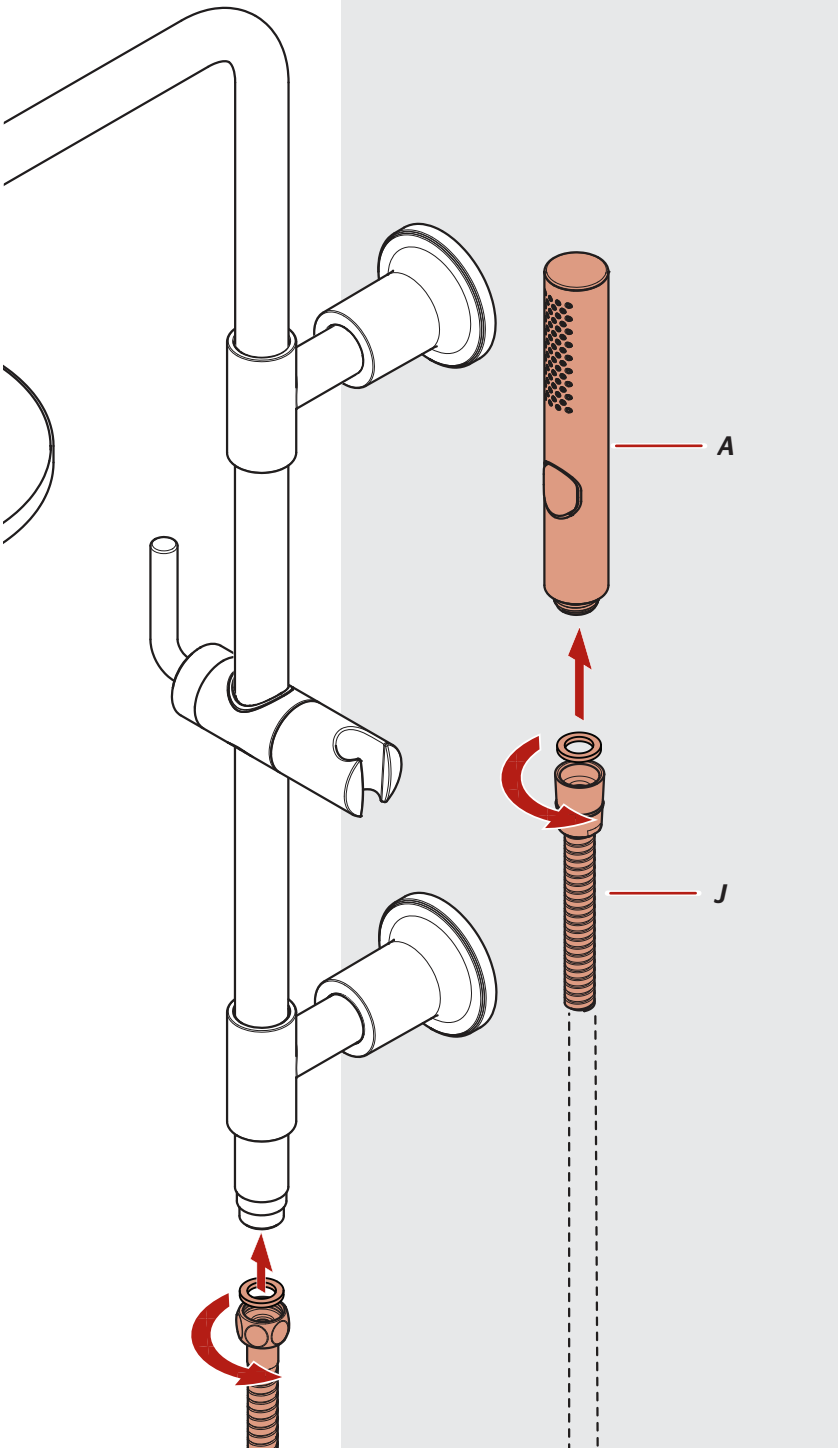

8 Turn On Water & Confirm Proper Installation

Active el suministro de agua y confirme que la instalación está adecuadamente efectuada
Ouvrez l'eau et confirmez que l'installation est adéquate

8A

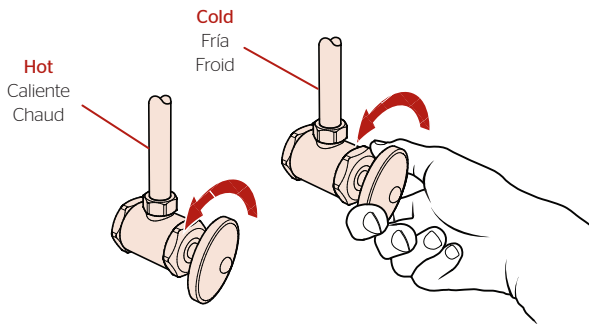

Turn on your water supply and check for leaks.

Abra el suministro de agua y verifique que no haya fugas.
Ouvrez l'alimentation en eau et vérifiez s'il y a des fuites.

9 Cradle Adjustments

Ajustes de Cuna
Ajustements du berceau

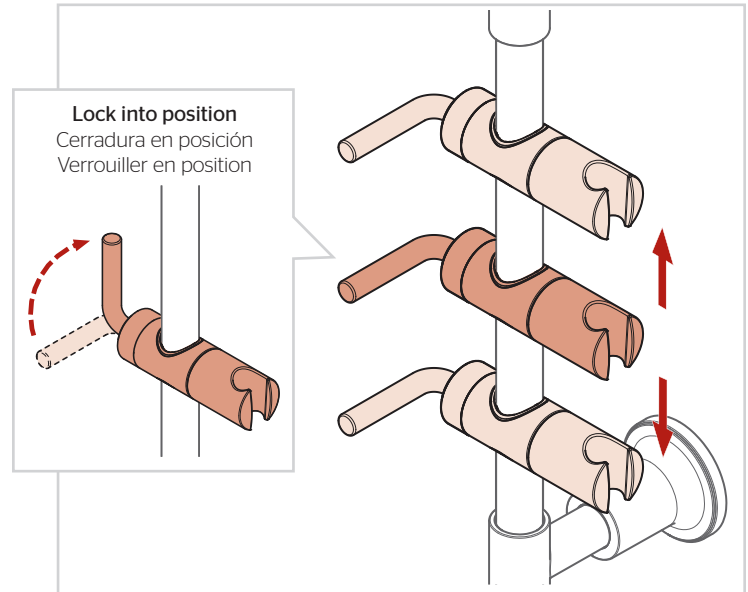

10 How to Use Diverter

Cómo utilizar el Desviador
Comment utiliser le Déviateur

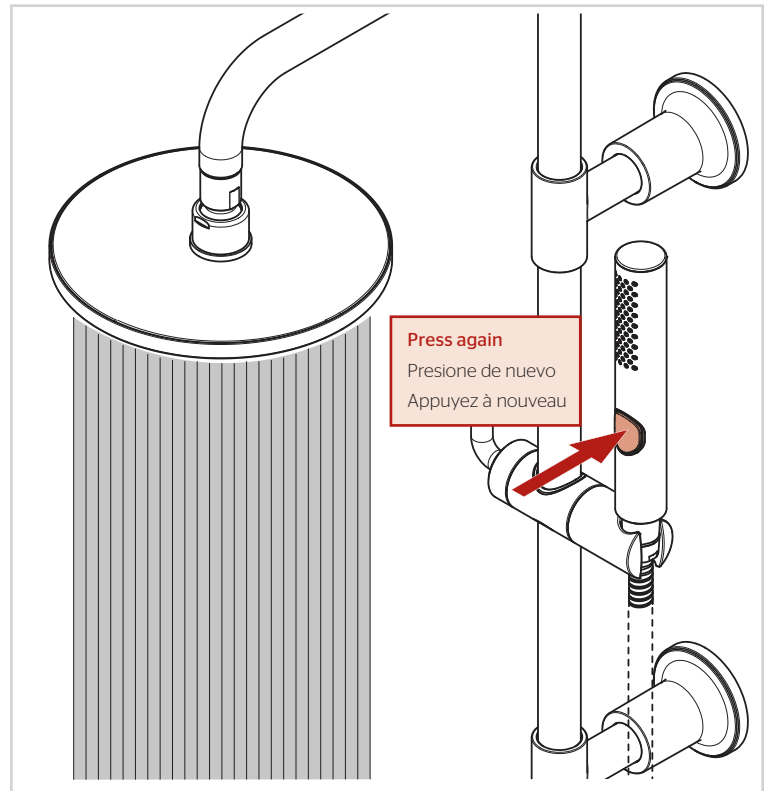
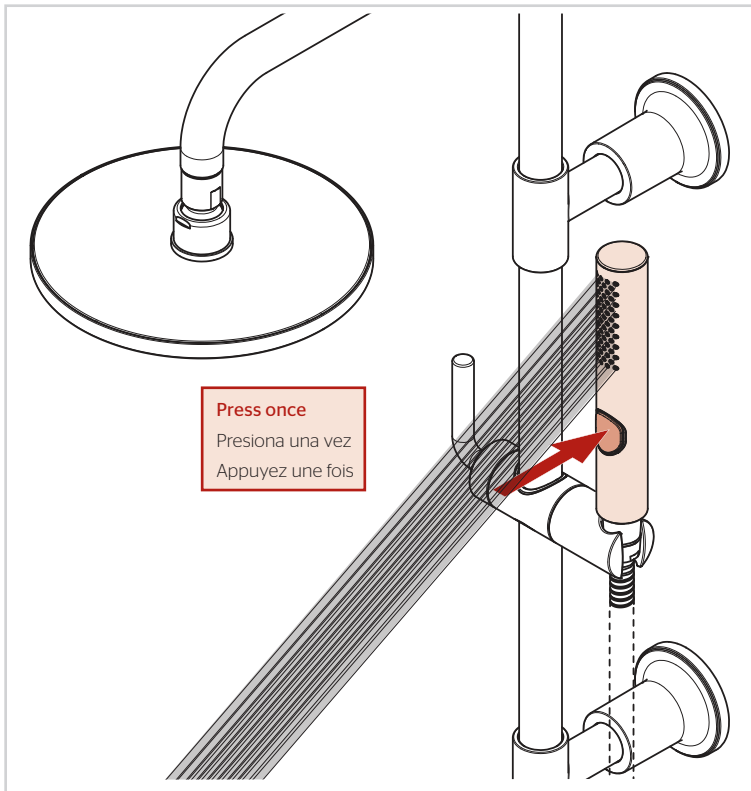

For Additional Installation Help:
Para la instalación adicionales de ayuda:
Pour les aides supplémentaires à l'installation:

Pfister

1-800-PFAUCET (732-8238)
pfisterfaucets.com

Tenet™
R89-1TNT/LG89-XTNT

*Tub & Shower Trim
Borde para bañera y ducha
Garniture de baignoire et douche*

Installation Support • Soporte de instalación • Support d'installation

Personal Assistance, Product Specs, & "How-to" Questions:

Asistencia personal, especificaciones del producto y preguntas sobre "cómo hacerlo":

Aide personnelle, spécifications du produit et questions « pratico-pratiques » :

1-800-PFAUCET (732-8238)

pfisterfaucets.com/support

Installation Videos Available
Vídeos de instalación a disposición
Vidéos d'installation disponibles



pfisterfaucets.com/videos

▲ WARNING / ADVERTENCIA / AVERTISSEMENT

To reduce the risk of injury or property damage, read all instructions before installing product. Wear safety goggles. Product must be installed in accordance with all state & local plumbing & building codes. Call a professional if you are uncertain about installing this product.

This product has been designed for use with the Pfister™ OX8 Series Pressure Balancing Valve. It will not work with any other product valve. Please review the OX8 valve installation instructions before installing this product.

Para disminuir el riesgo de lesiones o daños a la propiedad, lea todas las instrucciones antes de instalar el producto. Utilice gafas de seguridad. El producto deberá instalarse de acuerdo con la normativa de plomería y construcción estatal y local. Llame a un profesional si no está seguro sobre cómo instalar este producto. Este producto ha sido diseñado para usar con la válvula de equilibrio de presión de la Serie OX8 de Pfister™. No funcionará con cualquier otra válvula. Revise las instrucciones de instalación de la válvula OX8 antes de instalar este producto.

Pour réduire le risque de blessures ou de dommages, lire toutes les instructions avant d'installer l'appareil. Porter des lunettes de sécurité. Il faut installer l'appareil en respectant tous les codes de construction et de plomberie locaux et d'État. Appelez un professionnel si vous n'êtes pas certain de la façon d'installer cet appareil. Cet appareil a été conçu pour être utilisé avec la valve d'équilibrage de pression Pfister™ OX8. Il ne fonctionnera pas avec la valve d'un autre appareil. Veuillez lire les instructions d'installation de la valve OX8 avant d'installer ce produit.

**Required Tools
Herramientas necesarias
Outils nécessaires**



Teflon Tape
Cinta de teflón
Ruban en téflon



Adjustable Wrench
Llave ajustable
Clé réglable

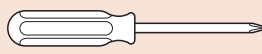

Phillips Screwdriver
Destornillador de estrella
Tournevis Phillips



Safety Goggles
Anteojos de seguridad
Lunettes de sûreté

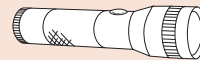

Flashlight
Linterna
Lampe-torche



Cloth
Paño de limpieza
Chiffon

Parts in the Box • Piezas en la caja • Pièces dans la boîte

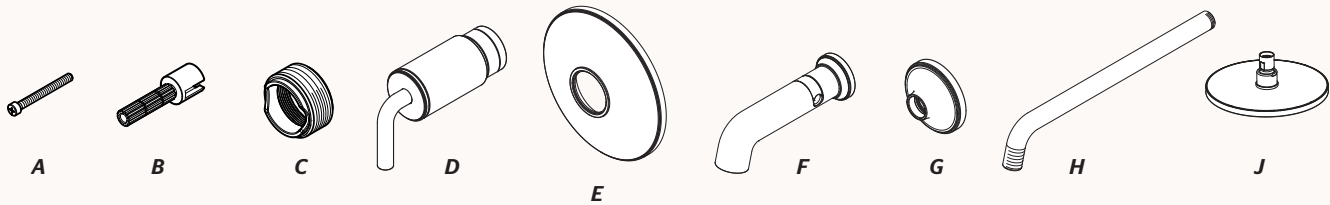

1 Turn Off Water Supply • Cierre el suministro de agua • Couper l'alimentation en eau

Locate water supply inlets and shut off the water supply valves. These are usually found under the sink or near the water meter. If you are replacing an existing faucet, remove the old faucet from the sink and clean the sink surface thoroughly.

Ubique las entradas del suministro de agua y cierre las válvulas de suministro de agua. Generalmente se encuentran debajo del fregadero o cerca del medidor de agua. Si se trata de un reemplazo de grifo, quite el grifo viejo y limpie completamente la superficie del fregadero.

Repérer les arrivées d'eau et fermer leurs robinets. Ces robinets se trouvent généralement sous le lavabo ou à côté du compteur d'eau. En cas de remplacement d'un robinet existant, le déposer du lavabo et nettoyer soigneusement la surface de ce dernier.

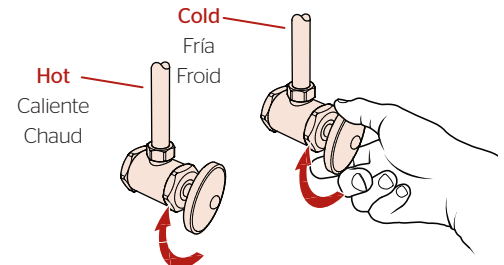

2 Prepare for Installation

Preparación para la instalación

Préparez pour installer

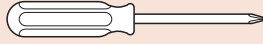

Phillips Screwdriver
Destornillador de estrella
Tournevis Phillips

No Parts Required for This Step
No se necesitan piezas para este paso
Aucune pièce nécessaire pour cette étape

2A

Work Area Inspection Inspección del área de trabajo Contrôle de la zone de travail

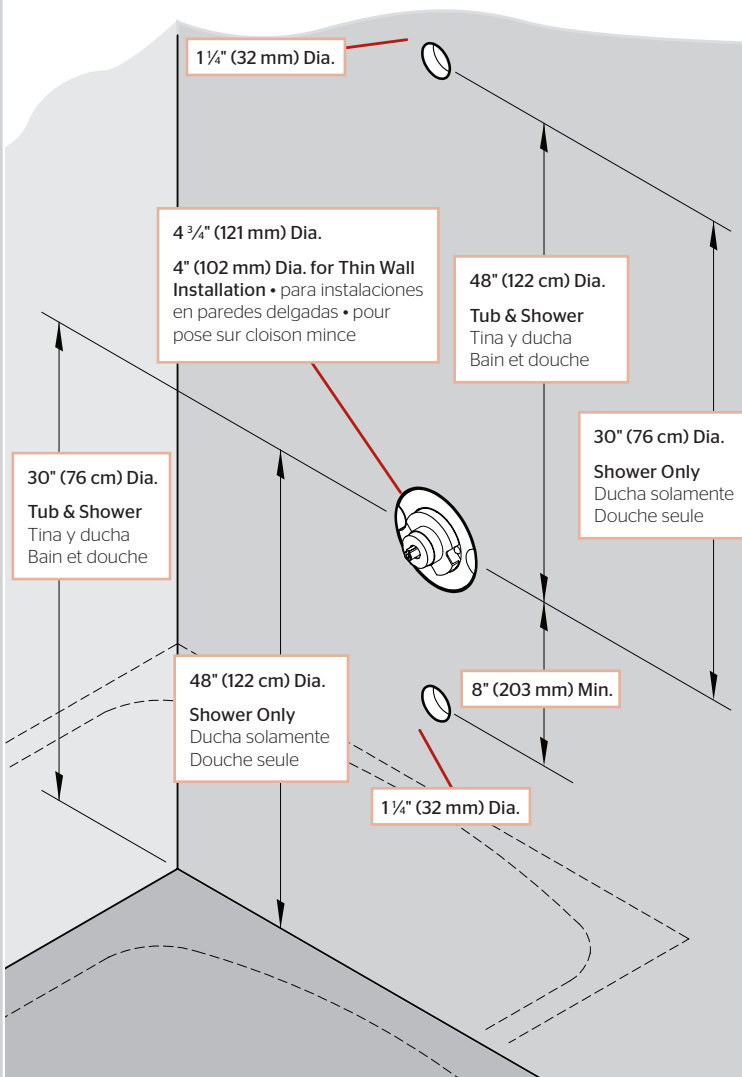

2B

Plasterguard Options Opciones para cubierta protectora para yeso Options de para-plâtre

Thin Wall Installation (1 3/8" Max)

Instalación en pared delgada (35 mm)

Installation avec mur mince (35 mm)

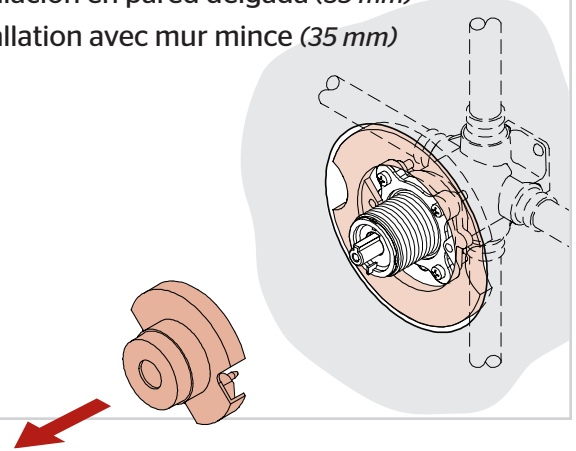

Thick Wall Installation (2 3/4" Max)

Instalación en pared gruesa (41 mm - 70 mm)

Installation avec mur épais (41 mm - 70 mm)

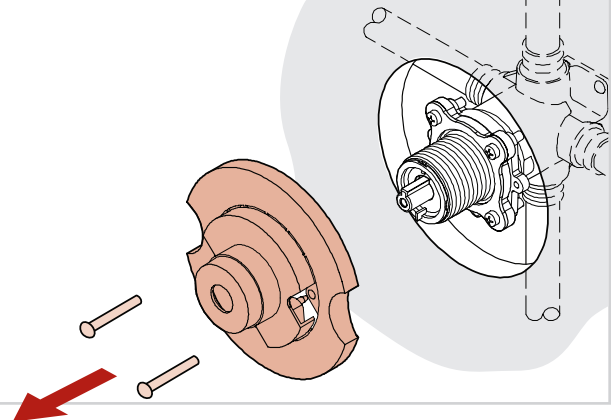

3 Install Retainer and Stem - Instale el anillo de retención y el tallo - Installez retenue et la tige

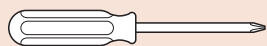

Phillips Screwdriver
Destornillador de estrella
Tournevis Phillips

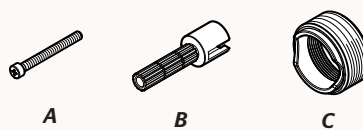

3A

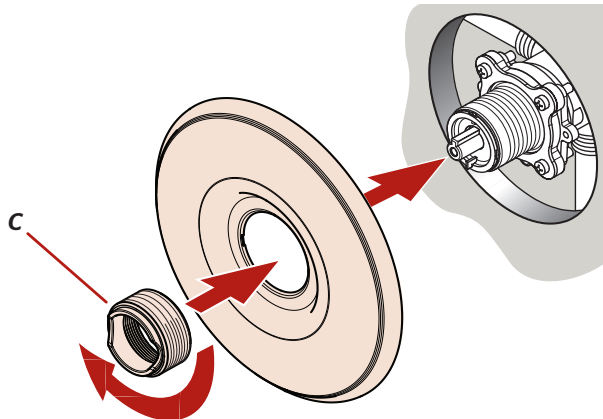

3B

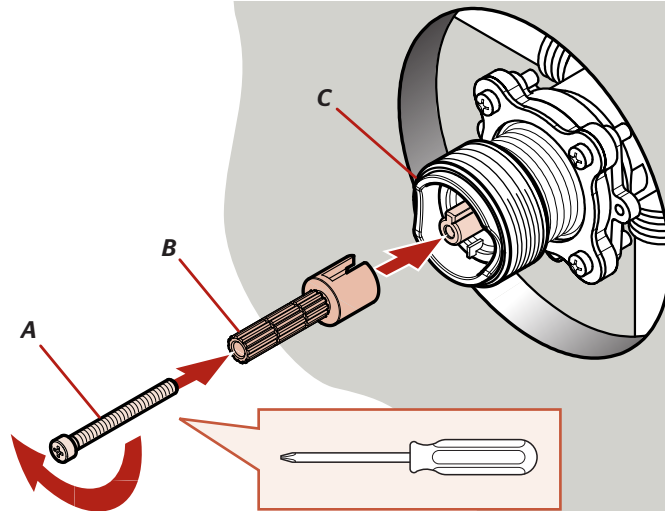

4 Install Flange and Handle - Instale la brida y el mango - Installez la bride et gérer

No Tools Required for This Step
No se necesitan herramientas para este paso
Aucun outil n'est nécessaire pour cette étape

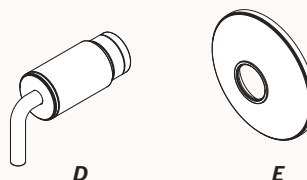

4A

Ensure Ring is on Handle as shown.

Asegúrese que el anillo está en el mango como se muestra.
Assurez-vous que l'anneau sur la poignée comme indiqué.

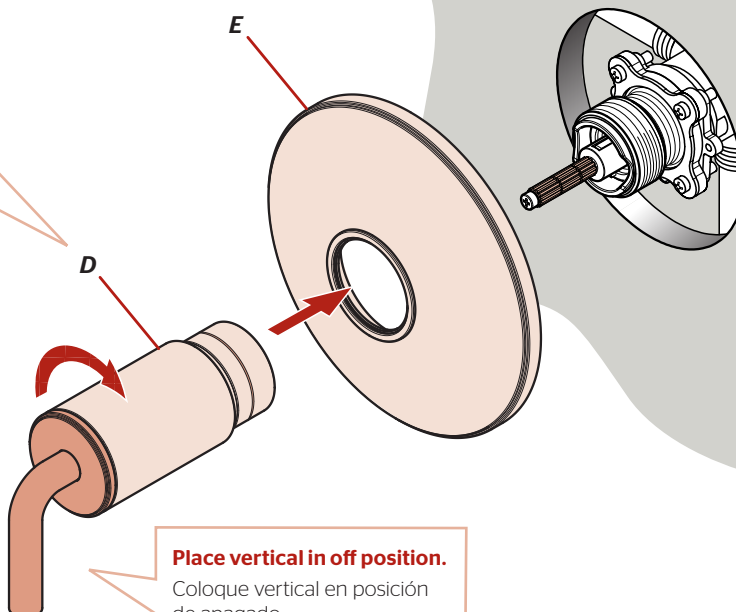
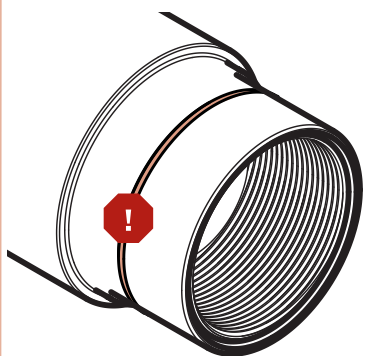

Place vertical in off position.

Coloque vertical en posición de apagado.
Placez vertical en position d'arrêt.

Extension Kit 970-083 offers an additional 7/8" if valves are roughed in too deep.
Kit de Extensión de 970-083 ofrece un adicional de 7/8" si la válvula se desbastada demasiado dentro al pared.
970-083 kit d'extension fournit un supplément de 7/8 "si la vanne est coupée trop loin dans le mur.

5

Connect Shower Arm & Spout

Conecte el brazo de la ducha y el surtidor

Branchez le bras de douche & le bec



Teflon Tape
Cinta de teflón
Ruban en téflon

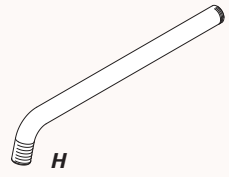
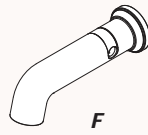

5A

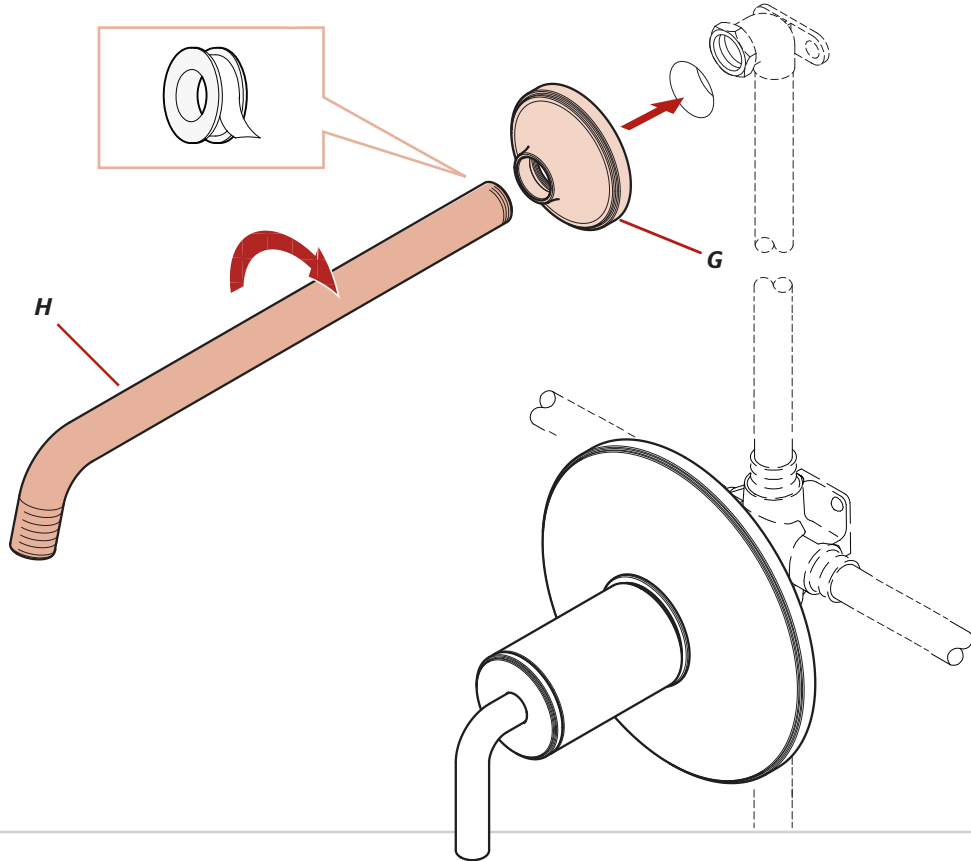

5B

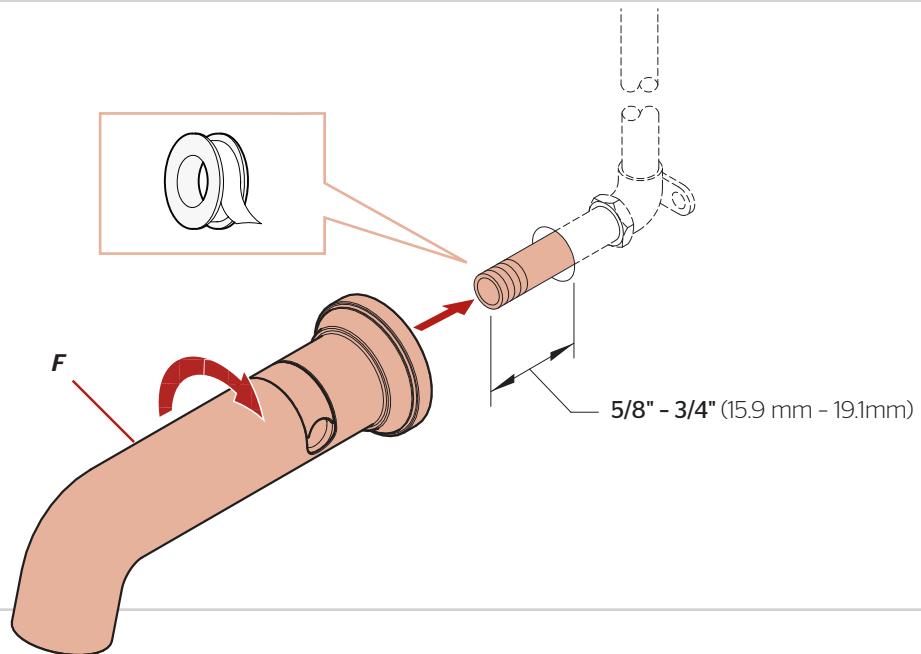

6 Turn On Water & Flush

Active el suministro de agua y enjuague

Ouvrez l'eau et vidangez



Teflon Tape
Cinta de teflón
Ruban en téflon

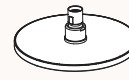

J

6A

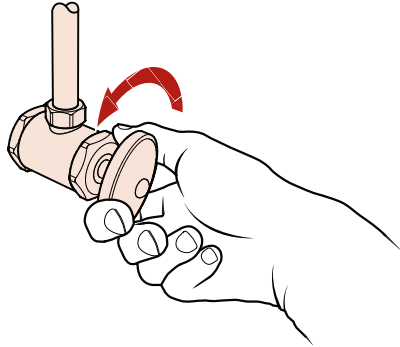

Turn on your water supply & check for any leaks.

Active el suministro de agua y revise si hay fugas.

Rétablissez l'alimentation en eau et vérifiez s'il y a des fuites.

Shower Functions • Funciones de la ducha • Fonctions de la douche

Pull up to turn on shower.

Hale hacia arriba para activar la ducha.

Tirez vers le haut pour mettre la douche en marche.

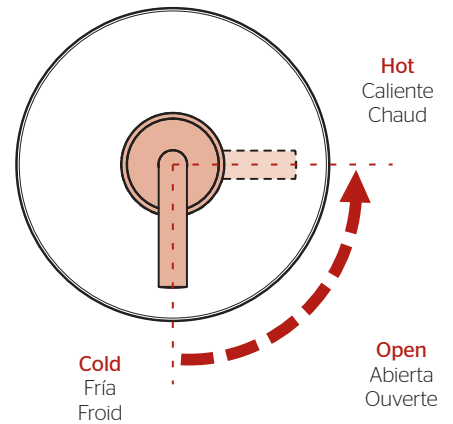
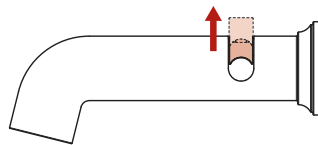

6B

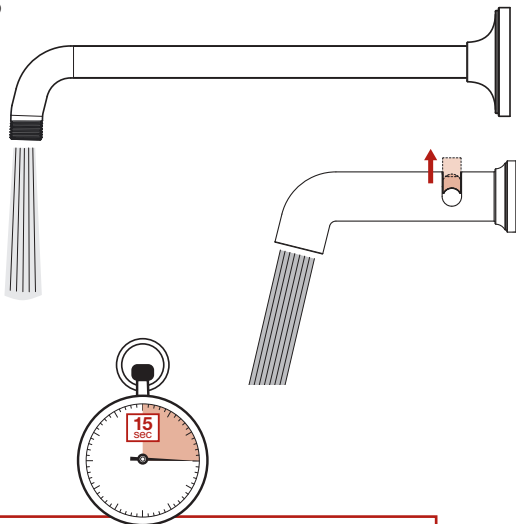

Allow full hot & full cold water to run for at least 15 seconds each.

Deje correr el agua caliente y fría durante al menos 15 segundos cada una.

Permettez à l'eau chaude et l'eau froide de couler au moins 15 secondes chacun.

6C

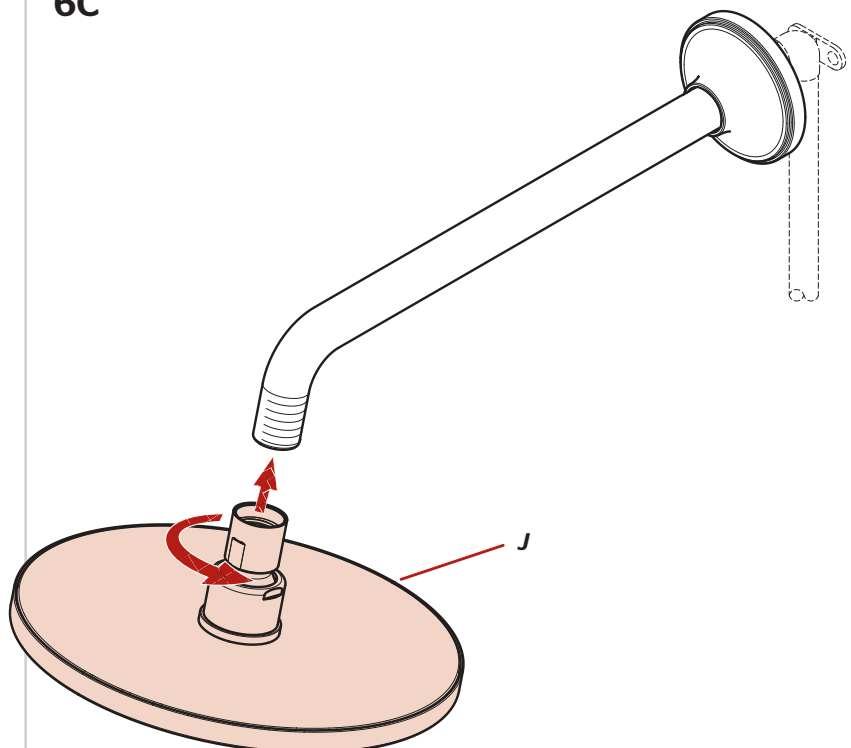

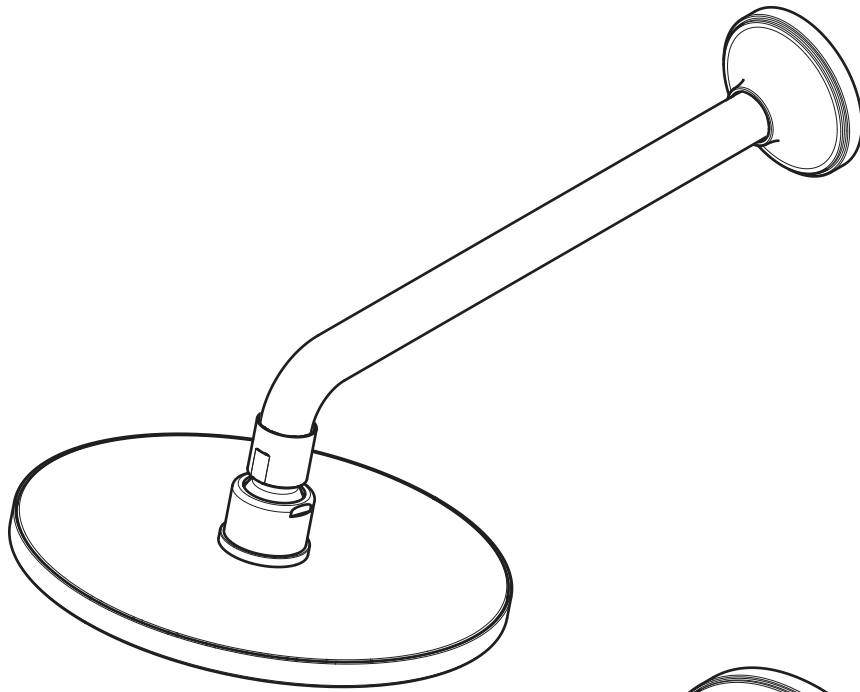

SAMPLE COPY

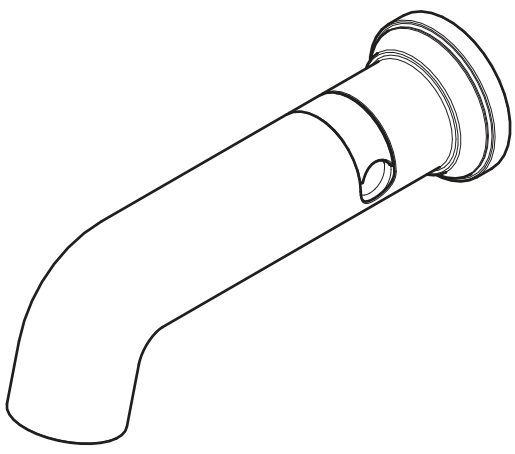

For Additional Installation Help:

Para la instalación adicionales de ayuda:

Pour aider à l'installation supplémentaires:

Pfister[®]

1-800-PFAUCET (732-8238)
pfisterfaucets.com