

Ventilating Fan

INSTALLATION INSTRUCTIONS

Model No.

FV-13VKML3

FV-13VKSL3 FV-13VKL3

FV-08VKML3

FV-08VKSL3 FV-08VKL3

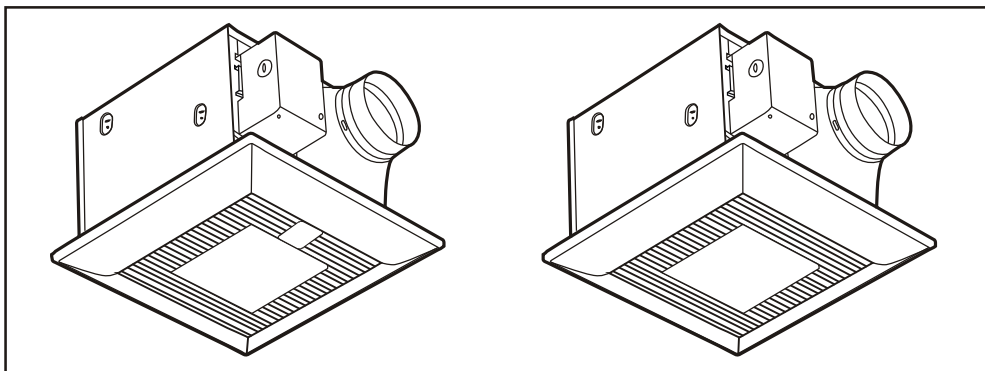

READ AND SAVE THESE INSTRUCTIONS

Thank you very much for having purchased our Ventilating Fan. Please read these instructions carefully before attempting to install, operate or service the Panasonic Ventilating Fan. Failure to comply with instructions could result in personal injury and/or property damage. Please retain this booklet for future reference.

Table of Contents

Please Read Prior To Installing This Fan	2
Unpacking	3
Supplied Accessories	3
Description	3
General Safety Information	4
Dimensions	5
Wiring Diagram	5-6
Switch Indication	6
Operation	6-7
Installation I (Joist Mounting - I)	7-9
Installation II (Suspension Brackets Mounting)	10
Installation III (Joist Mounting - II)	10
Maintenance I (Cleaning)	11
Maintenance II (Replacement of lamp)	11
Practical Guide To Installation	Back cover
Specifications	Back cover
Product Service	Back cover

PLEASE READ PRIOR TO INSTALLING THIS FAN

[For models of: FV-13VKML3, FV-08VKML3, FV-13VKSL3, FV-08VKSL3.]

The WhisperGreen line of ventilating fans employs state of the art technology providing a number of unique features that lead to improved indoor air quality. These features need to be fully understood prior to installation to full realize the benefits fans offer.

Spot and Continuous Ventilation: These fans are designed to run continuously ensuring a healthy environment at low CFM levels 24 hours a day. By utilizing CustomVent Variable Speed Control the fans are built to run continuously at a pre-set lower level (FV-13VKML3 and FV-13VKSL3:0,50,70,90, 110 CFM ; FV-08VKML3 and FV-08VKSL3:0,30,40,50,60,70 CFM). The setting is dependent on the size of the room and the individual wishes of the homeowner. It is crucial that the installer pre-set the lower setting during the installation. Please refer to the chart below and page 5 of the installation instructions.

**CustomVent Variable Speed Control (Lower Setting).
ASHRAE 62.2-2007**

(sq.feet)	Two Bedrooms	Three Bedrooms	Four Bedrooms	Five Bedrooms
< 1, 000	33	40	48	55
1,500	38	45	53	60
2,000	43	50	58	65
2,500	48	55	63	70
3,000	53	60	68	75
3,500	58	65	73	80
4,000	63	70	78	85
4,500	68	75	83	90
5,000	73	80	88	95
5,500	78	85	93	100
6,000	83	90	98	105
6,500	88	95	103	110
7,000	93	100	108	-

These fans are also built to take care of the homeowner's spot ventilation needs when the room is occupied. This models kick-up to a maximum level of 130 CFM for the FV-13VKML3 and FV-13VKSL3 and 80CFM for the FV-08VKML3 and FV-08VKSL3 either when the switch is turned on (available with FV-13VKSL3 and FV-08VKSL3) or activated by the SmartAction Motion Sensor (available with FV-13VKML3 and FV-08VKML3).

A High / Low Delay Timer, located inside the fan unit, is utilized to return the fan back to the pre-set Continuous ventilation mode. The installer needs to consult with the homeowner for the desired setting on the timer (0.5 - 60 minutes) and make the adjustments during the installation.







Optimum Ventilation Performance: Generally duct length, elbows and other factors increase static pressure hindering the performance of most ventilation fans. This fan utilize SmartFlow microchip technology that monitors the static pressure in the system and speeds up or slows down the rpm of the fan depending on the amount of resistance. This allows the fan to perform as rated, whether facing 0.1,0.2 or even 0.25 inches water gauge. The bottom line is that it makes for easier installation. The installer no longer has to worry about compromising the fan's performance.





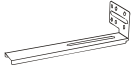

Outstanding Energy Savings: These fans are the very first to be built using DC motor technology. The new DC motor is 30% - 70% more energy efficient than the minimum ENERGY STAR requirements.

UNPACKING

Unpack and carefully remove the unit from carton.
Refer to the Supplied Accessories list to verify that all parts are present.

SUPPLIED ACCESSORIES

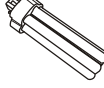
Part name	Appearance	Quantity
Grille	 For models of: FV-13VKML3 FV-08VKML3	1
	 For models of: FV-13VKSL3 FV-08VKSL3 FV-13VKL3 FV-08VKL3	
Suspension bracket I		1
Suspension bracket II		1
Suspension bracket III		1
Suspension bracket IV		1

Part name	Appearance	Quantity
Screw I (ST4.2X6)		2
Screw II (ST4.2X14)		1
Long screw (ST4.2X20)		6
Installation instructions		2
Warranty sheet		1
32W Fluorescent lamp		1
4W Night lamp		1

DESCRIPTION

These Panasonic ventilating fan models are listed by UL under UL file No. E78414.

These Panasonic ventilating fan models use a sirocco fan driven by a DC motor powered by an integral transformer. The motor is designed to have long operating life, high dynamic response, higher speed ranges with saving energy. The grille covering the fan body is a spring-loaded, quick remove type.

A damper for preventing air counter flow is provided.

The blower uses a high-capacity sirocco fan developed to reduce the noise level.

Panasonic ventilating fan models FV-13VKML3 and FV-08VKML3 are equipped with a motion sensor that shifts the fan to high flow automatically when motion is detected. It is user-adjustable to operate 0.5~60 minutes after motion is no longer detected.

The lighting unit is an energy-saving, lighting device that uses one 32W fluorescent lamp and produces almost the same illumination as a standard 100W incandescent lamp.

This product contains an electronic ballast with one fluorescent lamp and is in compliance with Part 18 of the FCC rules as consumer RF lighting device. Operation is subject to the following two conditions:

- (1) This device may not cause harmful interference,
- (2) This device must accept any interference received, including interference that may cause undesired operation.

This product may cause interference to radio equipment and should not be installed near maritime safety communications equipment or other critical navigation or Communication equipment operating between 0.45-30 MHz. If interference should occur, try to increase spacing between this product and the other product.

Doc Responsible Party: Panasonic Corporation of North America
One Panasonic Way, Secaucus, New Jersey 07094

Sales Company: Panasonic Corporation of North America
One Panasonic Way, Secaucus, New Jersey 07094

Customer Call Support: 1-866-292-7292

GENERAL SAFETY INFORMATION

1. Do not install this ventilating fan where interior room temperature may exceed 104°F (40°C).
2. Make sure that the electric service supply voltage is AC 120V, 60Hz.
3. Follow all local electrical and safety codes, as well as the National Electrical Code (NEC) and the Occupation Safety and Health Act (OSHA).
4. Always disconnect the power source before working on or near the fan, motor, light fixture or junction box.
5. Protect the power cord from sharp edges, oil, grease, hot surfaces, chemicals or other objects.
6. Do not kink the power cord.
7. Do not install the unit where ducts are configured as shown in Fig. A.
8. Provide make up air for proper ventilation.
9. This product has a fluorescent lamp that contains mercury. Disposal may be regulated in your community due to environmental considerations. For disposal or recycling information, please contact your local authorities or the Electronics Industries Alliance: <http://www.eiae.org>

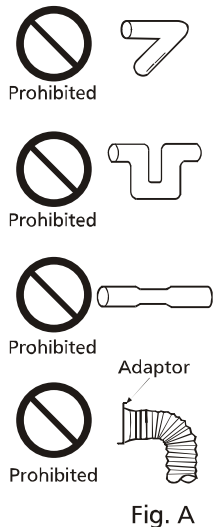

CAUTION:

1. For general ventilating use only. Do not use to exhaust hazardous or explosive materials and vapors.
2. Not for use in cooking area. (Fig.B)
3. This product must be properly grounded.

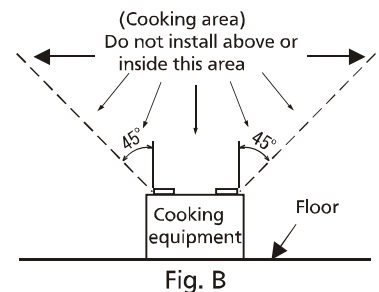

WARNING:

To reduce the risk of fire, electric shock or injury to persons, observe the following:

1. Use this unit only in the manner intended by the manufacturer. If you have any questions, contact to the manufacturer.
2. Before servicing or cleaning unit, switch power off at service panel and lock the service disconnecting means to prevent power from being switched on accidentally. When the service disconnecting means cannot be locked, securely fasten a prominent warning device, such as a tag, to the service panel.
3. Installation work and electrical wiring must be done by qualified person(s) in accordance with all applicable codes and standards, including fire-rated construction.
4. Sufficient air is needed for proper combustion and exhausting of gases through the flue (chimney) of fuel burning equipment to prevent back drafting. Follow the heating equipment manufacturer's guideline and safety standards such as those published by the National Fire Protection Association (NFPA), and the American Society of Heating, Refrigeration, and Air Conditioning Engineers (ASHRAE) and the local code authorities.
5. When cutting or drilling into wall or ceiling, do not damage electrical wiring and other hidden utilities.
6. Ducted fans must always be vented to the outdoors.
7. If this unit is to be installed over a tub or shower, it must be marked as appropriate for the application and be connected to a GFCI (Ground Fault Circuit Interrupter)-protected branch circuit.
8. These models are UL listed for tub and shower enclosures.
9. Not to be installed in a ceiling thermally insulated to a value greater than R40.(This is required for installation in Canada only)
10. Do not use this fan with any solid-state speed control device. Solid state controls may cause harmonic distortion which can cause motor humming noise.
11. A statement to the effect that when the product is to no longer be used, it must not be left in place but removed, to prevent it from possibly falling.

DIMENSIONS

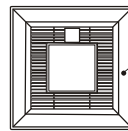
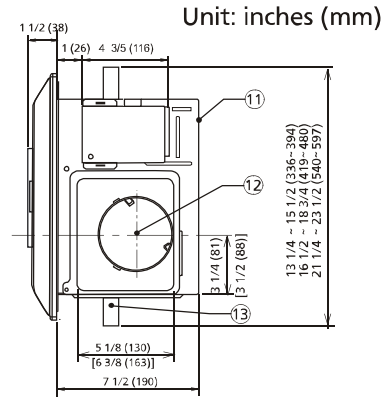
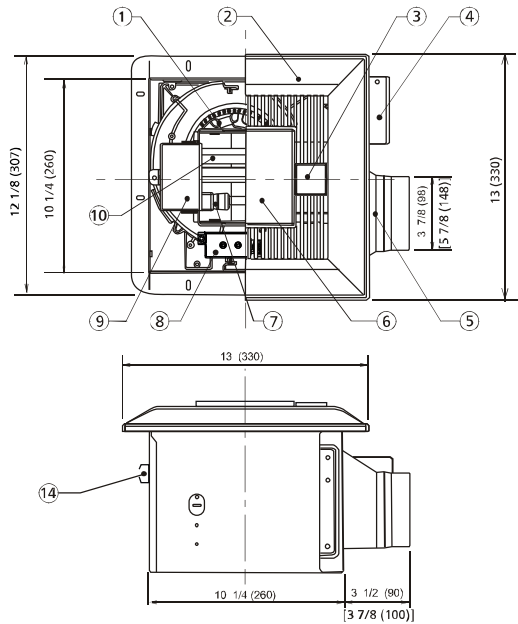

FV-13VKML3
FV-08VKML3

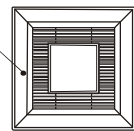

FV-13VKSL3 FV-13VKL3
FV-08VKSL3 FV-08VKL3

(The dimensions in square brackets refer to 13 models which are different from 08 models)

No.	Part name	No.	Part name
1	Blade	8	Switch unit (FV-13VKML3, FV-08VKML3, FV-13VKSL3, FV-08VKSL3 only)
2	Grille		
3	Sensor unit (FV-13VKML3, FV-08VKML3 only)	9	Lighting unit
4	Junction box	10	Fluorescent lamp
5	Adaptor	11	Fan body
6	Lens	12	Damper
7	Night lamp	13	Suspension bracket
		14	Bracket cover

WIRING DIAGRAM

FV-13VKML3 FV-08VKML3

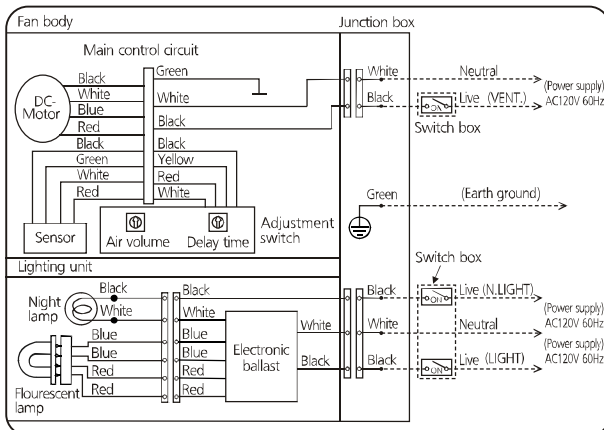

FV-13VKSL3 FV-08VKSL3

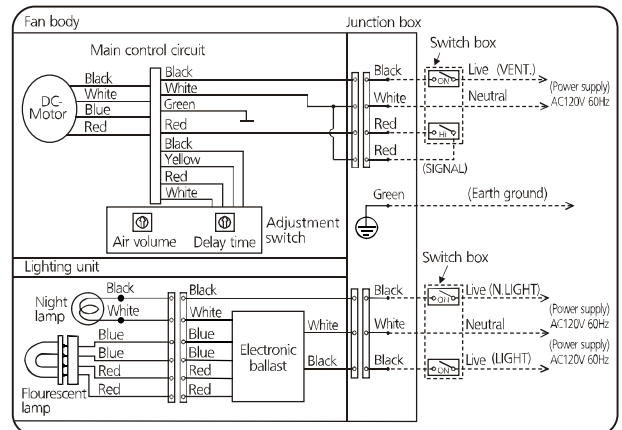

WIRING DIAGRAM (CONTINUED)

FV-13VKL3 FV-08VKL3

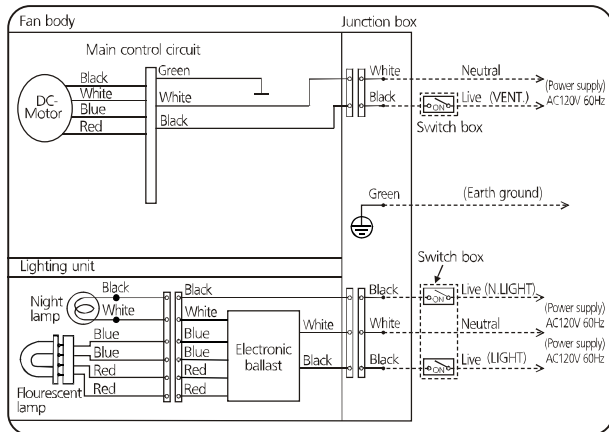

SWITCH INDICATION

FV-13VKML3
FV-13VKSL3

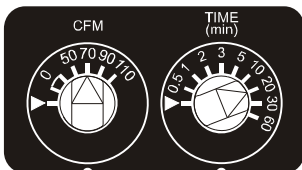

Switch indications on blower unit

FV-08VKML3
FV-08VKSL3

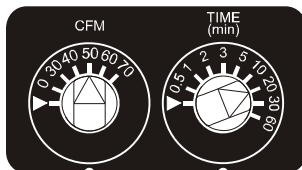

Switch indications on blower unit

Low speed air volume preset switch

High/Low delay time preset switch

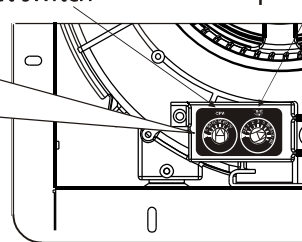

Low speed air-volume preset switch positions

FV-13VKML3 FV-13VKSL3	Air volume [CFM]	0	50	70	90	110
FV-08VKML3 FV-08VKSL3		0	30	40	50	60

Factory setting : FV-13VKML3/FV-13VKSL3: 70CFM;
FV-08VKML3/FV-08VKSL3: 50CFM.

Position "0" : Fan stop.

Position "▶" : use for factory test only.

High/Low delay time preset switch positions

Delay Time [min]	▶	0.5	1	2	3	5	10	20	30	60
---------------------	---	-----	---	---	---	---	----	----	----	----

Factory setting : 20 minutes.

Position "▶" : use for factory test only.

(Models of FV-13VKL3 and FV-08VKL3 have only one steady air volume.)

OPERATION

■ Sensor detectable range (For models of FV-13VKML3 and FV-08VKML3 only)

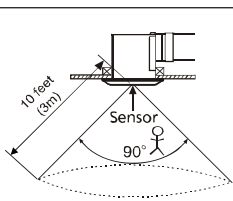
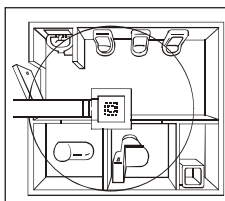







The distance that motion can be detected is limited to 10 feet (3m).
The field of view of the sensor is 90°.
(Room temperature is 25°C)

OPERATION (CONTINUED)

Motion

- The low speed is determined by air volume preset switch.
- The delay time is determined by High/Low delay time preset switch.
- The unit maintains the higher speed for an adjustable duration of 0.5 to 60 minutes, after motion is no longer detected.

FV-13VKML3 FV-08VKML3	Human active	INSIDE  	OUTSIDE 
	Fan active	At low speed	When motion is detected, fan runs at the high speed. Remains running at high speed until the delay time has passed.

FV-13VKSL3 FV-08VKSL3	Human active	INSIDE  	OUTSIDE 
	Fan active	At low speed	When manual wall switch is closed, fan runs at the high speed. When manual wall switch is opened, Fan remains running at high speed until the delay time has passed.

(Models of FV-13VKL3 and FV-08VKL3 have only one steady air volume, when the power switch is closed, FV-13VKL3 works steadily at 130CFM and FV-08VKL3 works steadily at 80CFM, when the power switch is opened, it will stop running.)

INSTALLATION I (JOIST MOUNTING - I)

Joist situation:

Spacing A is 16 inches (406 mm) to 24 inches (609 mm) on center joists

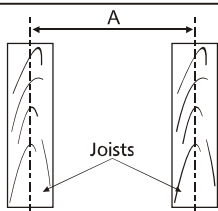

1. If the spacing A is 16 inches (406 mm) to 24 inches (609 mm) on center joists, please follow the installation step as below.

IMPORTANT:

Remove the tape from damper and adaptor before installation. As shown below:

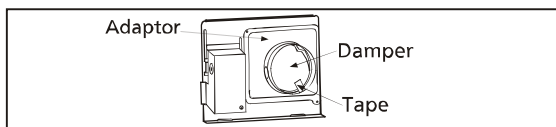

2. Insert the suspension bracket I and II into the fan body. (Select the suspension bracket connection holes as shown below) (Fig.1)

Suspension bracket connect method:

Suspension bracket I and II connect with screw I as shown below:

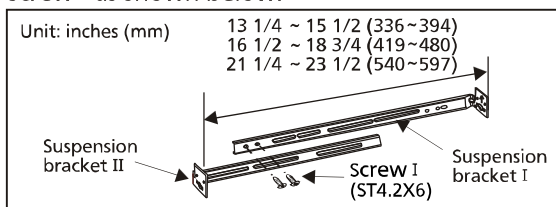

3. Install the suspension bracket and the flange of frame to joists by using long screws (ST4.2X20) and secure it to the fan body by using screw II (ST4.2X14). (Fig.2)

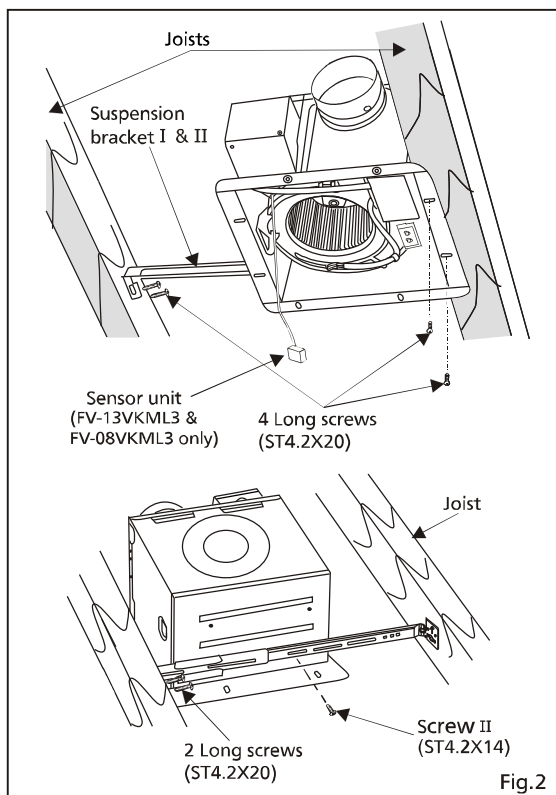
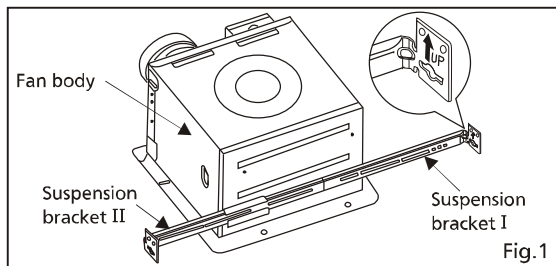

INSTALLATION I (JOIST MOUNTING -I) CONTINUED

4. Install a circular duct and secure it with clamps or wire ties and seal it with mastic or approved duct tape. (Fig.3)
5. Remove junction box cover and secure conduit or stress relief to junction box knock-out hole. (Fig.3)

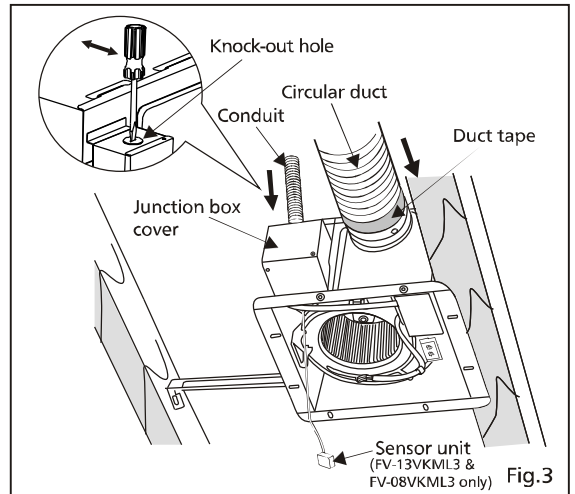

6. Refer to wiring diagram below.
Follow all the local electrical safety codes as well as the National Electrical Code (NEC).
Using UL approved wire nuts, connect house power wires to ventilating fan wires. (Fig.4-1, Fig.4-2)

CAUTION:
Mount junction box cover carefully so that lead wires are not pinched.

Note:
Wiring detail please refer to the wiring diagram on page 5 and page 6.

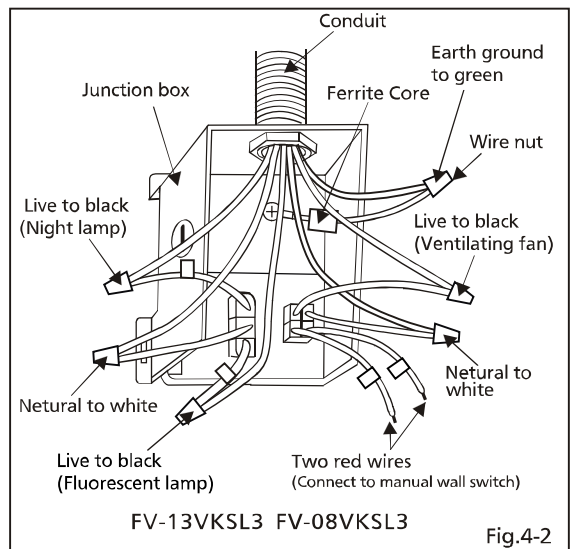
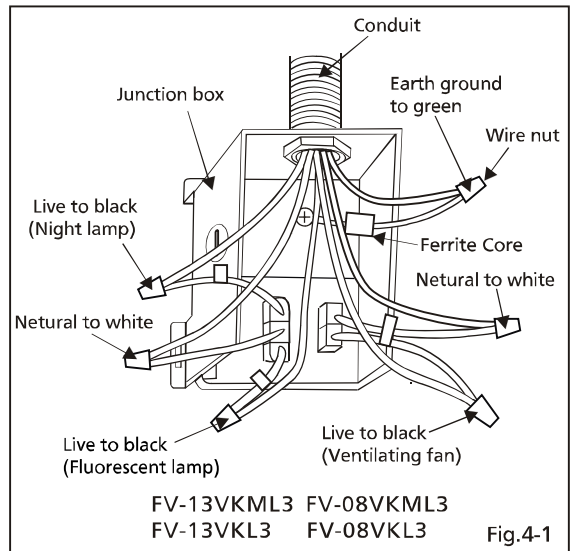

INSTALLATION I (JOIST MOUNTING -I) CONTINUED

7. Finish ceiling work. Ceiling hole should be aligned with the inside edge of the flange. (Fig.5)

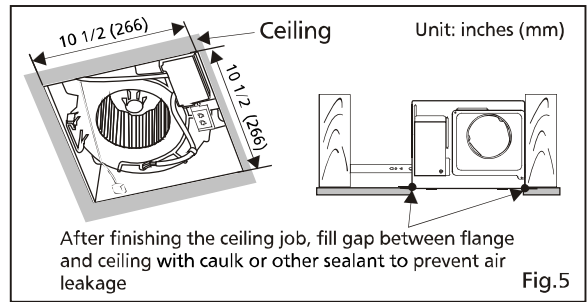

IMPORTANT:

Remove the tapes from louver and springs before installation. As shown below:

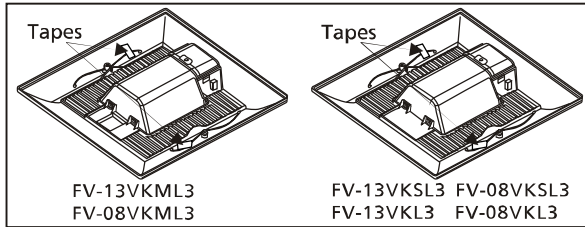

Install fluorescent lamp and night lamp as below:

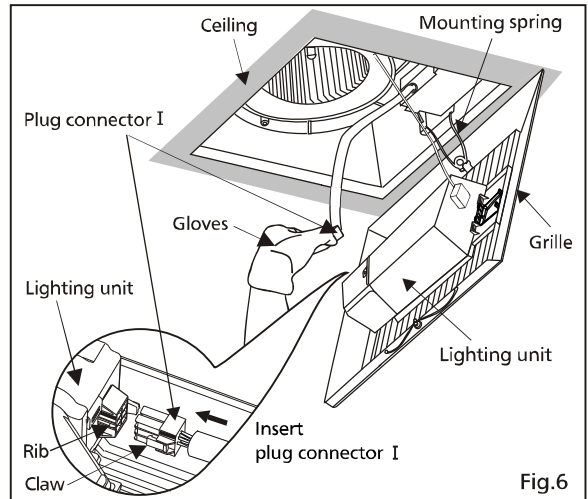
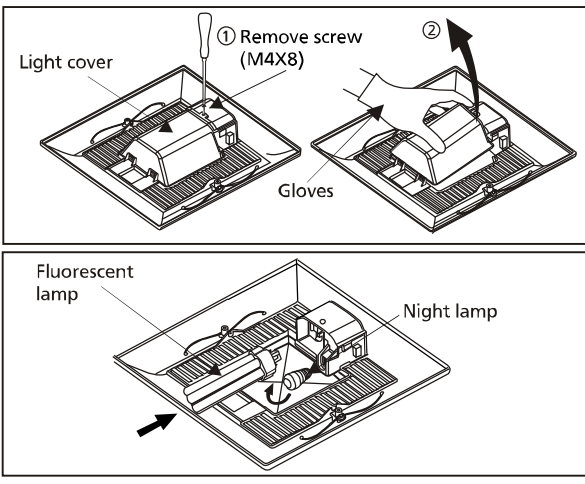

8. Insert the grille mounting spring on the wiring side into the slot and insert the plug connector I into the housing of the lighting unit. (Fig.6)

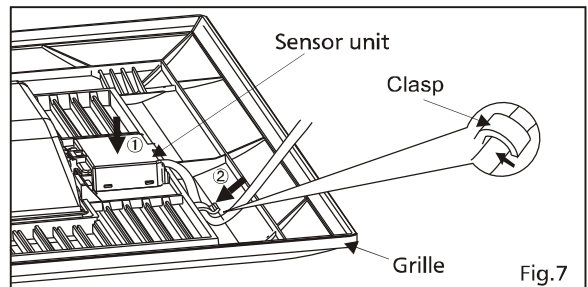

CAUTION:

- Before turn on the light, make sure the connector at the correct position.
- The claw of connector must latch the rib completely. (Fig.6)

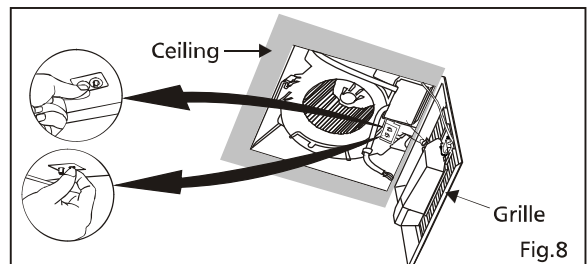

9. Insert the sensor unit into slot of the grille ; Fix the lead wire of sensor unit into the clasp (1 position). (FV-13VKML3 and FV-08VKML3).(Fig.7)

10. Adjust high / low delay time preset switch and low speed air volume preset switch (Fig.8). Refer to switch indication on page 7. (FV-13VKML3, FV-08VKML3, FV-13VKSL3 and FV-08VKSL3)

11. Insert another mounting spring into the slot as shown and mount grille to fan body. (Fig.9)

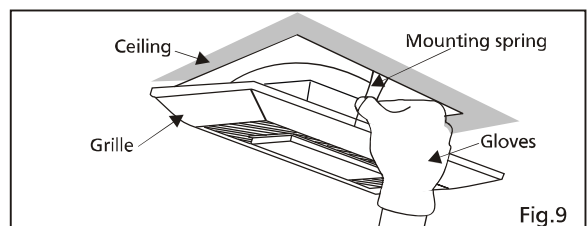

CAUTION:

Mount grille carefully so that lead wire of sensor unit and lighting unit is not pinched.

INSTALLATION II (SUSPENSION BRACKETS MOUNTING)

Joist situation:

Spacing A is 16 inches (406 mm) to 24 inches (609 mm) on center joists

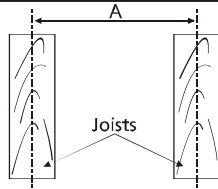

1. If the spacing A is 16 inches (406 mm) to 24 inches (609 mm) on center joists, please follow the installation step as below.
2. Insert the suspension bracket I and II into the fan body and suspension bracket III or IV into the adaptor. (Select the suspension bracket connection holes as shown below) (Fig.10, Fig.11)

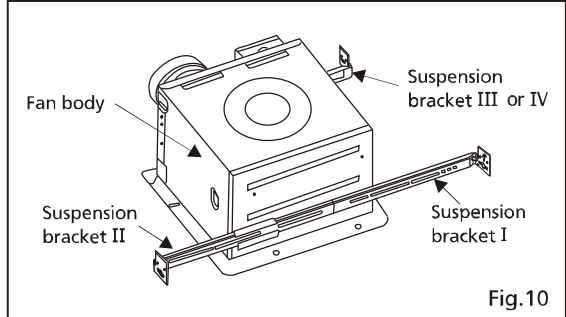
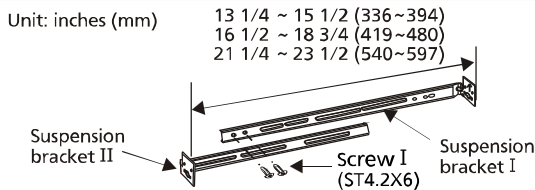

Fig.10

Suspension bracket connect method:

Suspension bracket I and II connect with screw I as shown below:



3. Install the suspension bracket to joists by using long screws (ST4.2X20) (Fig. 11) and secure it to the fan body by using screw II (ST4.2X14) (Fig. 12)
4. Follow steps 4 to 11 of installation I (page 8, page 9) to complete the installation work.

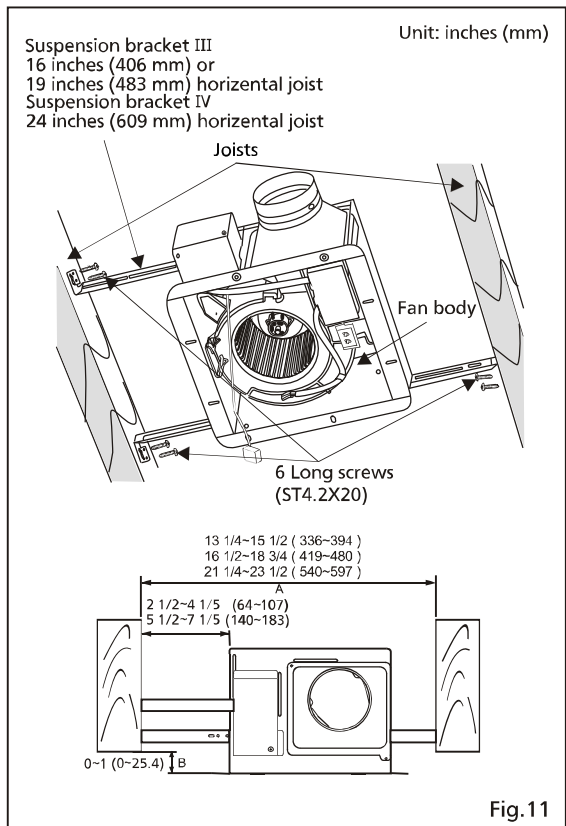

Fig.11

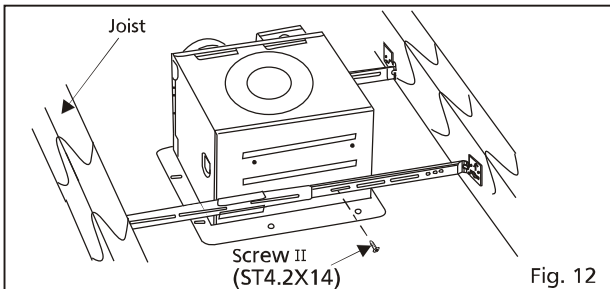
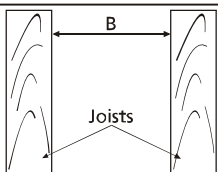

Fig. 12

INSTALLATION III (JOIST MOUNTING - II)

Joist situation:

Spacing B is 10 1/2 inches (266 mm) to 11 1/2 inches (292 mm) inches on joists



1. If the spacing B is 10 1/2 inches (266 mm) to 11 1/2 inches (292 mm) on joists, please follow the installation step as below.
2. Secure 4 long screws (ST 4.2X20) at flange of frame. (Fig. 13)
3. Follow steps 4 to 11 of installation I (page 8, page 9) to complete the installation work.

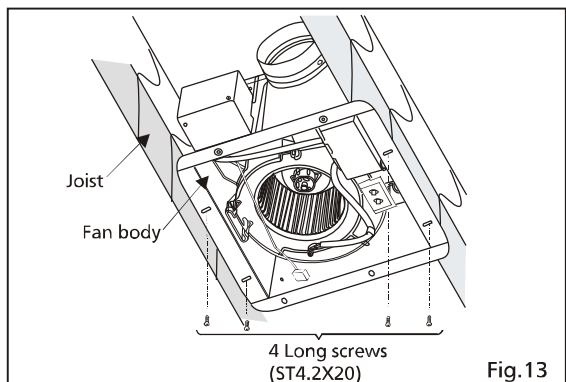

Fig.13

MAINTENANCE I (CLEANING)

WARNING:

Disconnect power source before working on unit. Routine maintenance must be done every year.

CAUTION:

1. Never use gasoline, benzene, thinner or any other such chemicals for cleaning the ventilating fan.
2. Do not immerse motor in water when cleaning.
3. Do not soak resin parts in water over 140°F (60°C).

1. Clean grille. (Don't put into hot water. Use non-abrasive kitchen detergent, wipe dry with clean cloth)(Fig.14)
2. The grille should be dry after cleaning.
3. Remove dust and dirt from fan body using a vacuum cleaner. (Fig.15)
4. Using a cloth dampened with kitchen detergent, remove any dirt from fan body. Wipe dry with clean cloth. (Fig.16)
5. Replace grille.

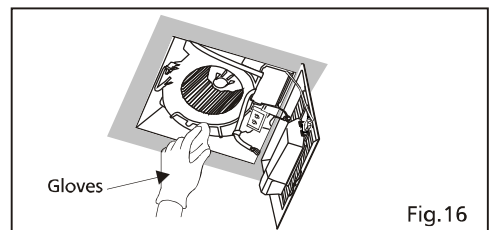
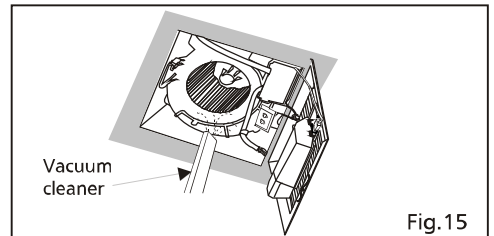
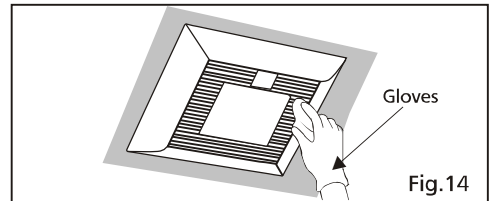

MAINTENANCE II (REPLACEMENT OF LAMP)

WARNING:

1. Disconnect power source before working on unit.
2. This is a pin type lamp base and the lamp's glass is fragile. To remove, pull out carefully.
3. 4W night lamp has threaded base. Remove by turning counterclockwise.
4. Make sure the temperature of lens and lighting unit has cooled down before maintenance (cleaning) or replacement of lamp.

1. Remove grille by pulling down one mounting spring. Remove plug connector I and sensor unit, (with sensor models only) then pull down another mounting spring. (Squeeze mounting spring and pull down carefully) (Fig.17)
2. Remove the screw as shown in step 1 of Fig. 18. Remove the light cover as shown in step 2 of Fig.18.
3. Replace the fluorescent lamp (Panasonic FHT32E35 32W) and/or the 4W night lamp. (Fig.19)

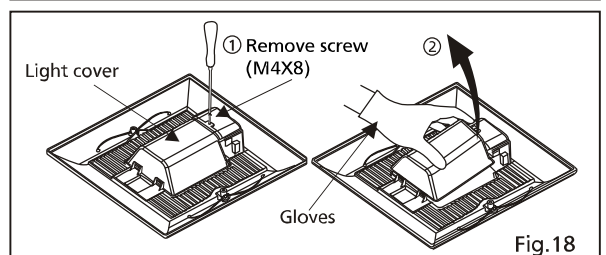
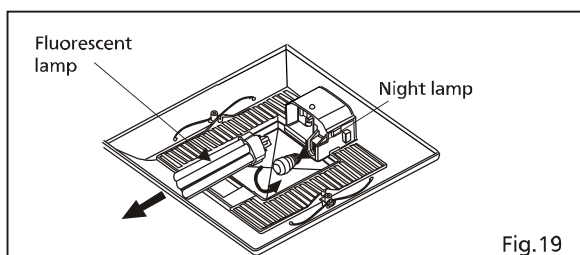
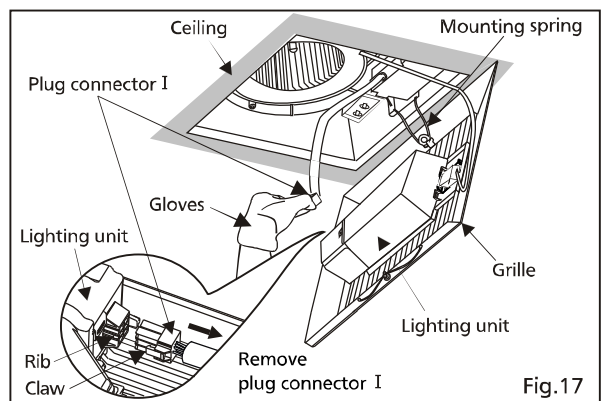

PRACTICAL GUIDE TO INSTALLATION

Properly insulate the area around the fan to minimize building heat loss and gain. (Fig.20)

Loose fill or batt insulation can be placed directly over the fan housing in the attic. Panasonic fans and fan/light combination units do not create excessive heat that is a common problem with recessed light fixtures or some competitors' fan/light combinations. Our efficient, cool-running motors and our fluorescent lamp do not create enough ambient heat to be subjected to these limitations.

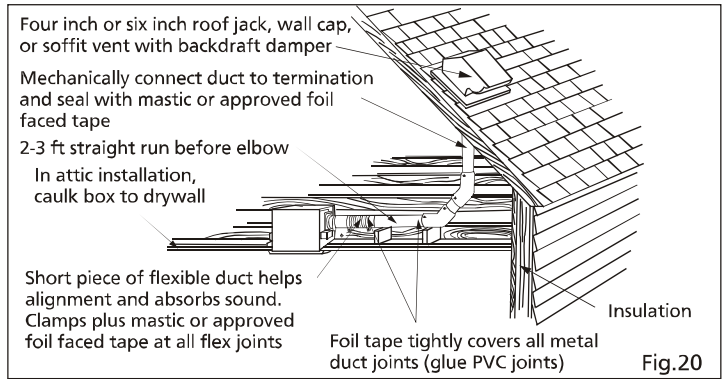

SPECIFICATIONS

■ Specifications

Model No.	Air direction	Voltage (V)	Frequency (Hz)	Duct diameter (inches)	Noise (sones)	Power consumption (W)			Speed (rpm)	Air volume at 0.1"WG (CFM)	Weight lb.(kg)
						Fan	Lighting unit				
							Fluorescent lamp	Night lamp			
FV-13VKML3 FV-13VKSL3 FV-13VKL3	Exhaust	120	60	6	0.8	16	32	4	746	130	11.7(5.3)
FV-08VKML3 FV-08VKSL3 FV-08VKL3	Exhaust	120	60	4	<0.3	8	32	4	869	80	11.2(5.1)

HVI Certified performance based on HVI Procedures 915,916,and 920.

■ Reference specifications

Model No.	Air direction	Voltage (V)	Frequency (Hz)	Duct diameter (inches)	Noise (sones)	Power consumption (W)	Speed (rpm)	Air volume at 0.1"WG (CFM)	Weight lb.(kg)
FV-13VKML3 FV-13VKSL3	Exhaust	120	60	6	0.6	11.2	708	110	11.7(5.3)
					0.3	8	674	90	
					<0.3	6.3	661	70	
					<0.3	4.8	645	50	
					—	0.5 (*)	—	0	
FV-08VKML3 FV-08VKSL3	Exhaust	120	60	4	<0.3	6.5	828	70	11.2(5.1)
					<0.3	5.6	798	60	
					<0.3	4.8	776	50	
					<0.3	4.2	765	40	
					<0.3	3.8	756	30	
					—	0.5 (*)	—	0	

Reference performance based on HVI Procedures 915, 916, and 920. [(*) Standby wattage.]

PRODUCT SERVICE

Warning Concerning Removal of Covers.

The unit should be serviced by qualified technicians only.

Your product is designed and manufactured to ensure a minimum of maintenance.

Should your unit require service or parts, call Panasonic Call Center at 1-866-292-7292 (USA) or 1-800-669-5165 (Canada).

Panasonic Corporation of North America

One Panasonic Way, Secaucus, New Jersey 07094
www.panasonic.com

Panasonic Canada Inc.

5770 Ambler Drive, Mississauga, Ontario L4W 2T3
www.panasonic.ca

T1011-1 13KML3420A
Printed in China