

STAINLESS STEEL D9000 & D9000S

NOTE: Template may not be true-to-size. Please use for reference purposes only. Do NOT drill until measurements are verified.

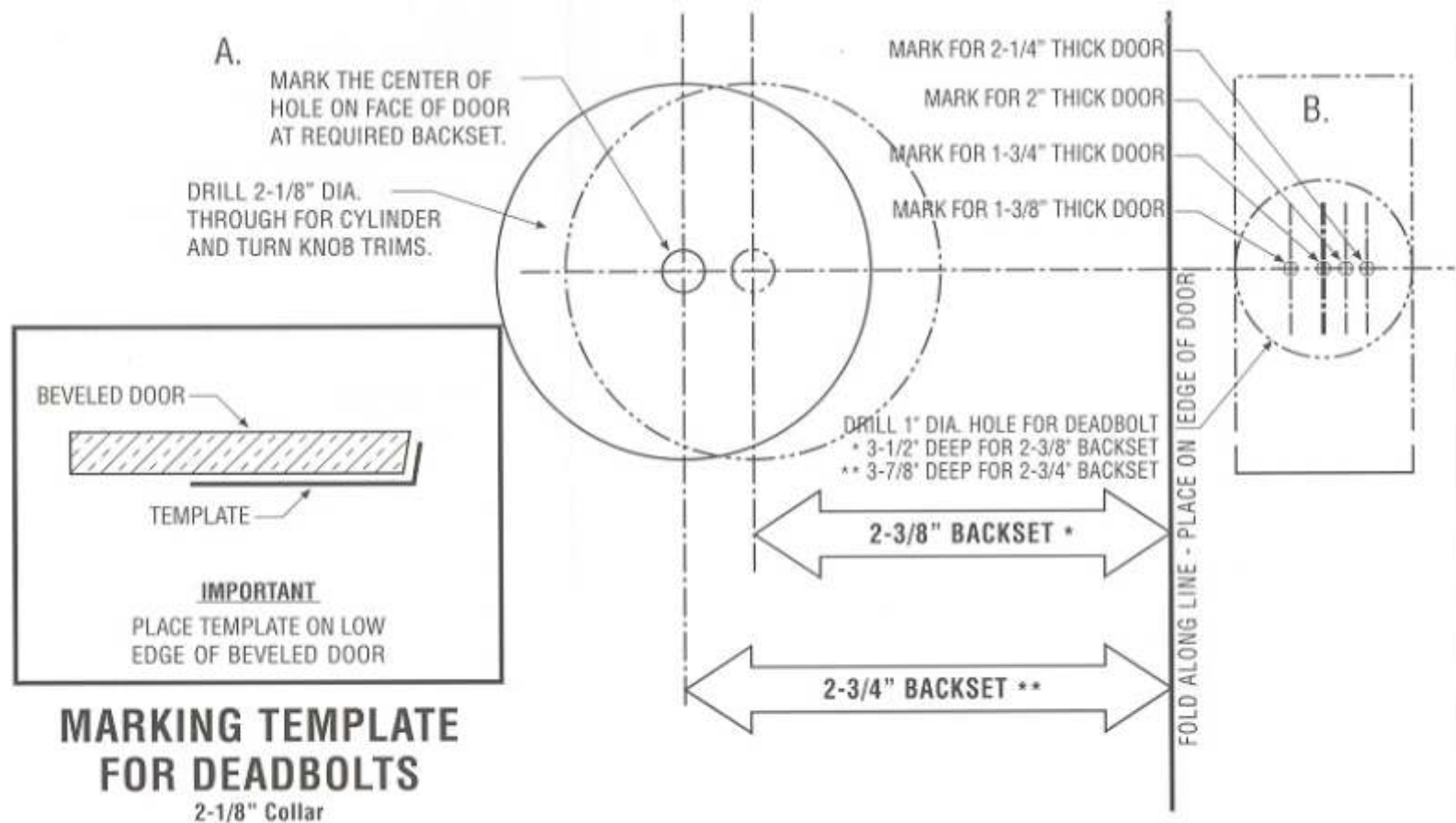

CHECK BACKSET BEFORE DRILLING!

BACKSET LOCATIONS ARE CALCULATED FOR LOW SIDE OF BEVELED DOORS.

CAUTION: DOOR AND FRAME MANUFACTURERS
 When door gasketing or silencers are used, proper allowances must be made for strike location to maintain a common centerline with lock and door so that the bolt will freely enter strike.

NOTE: Template may not be true-to-size. Please use for reference purposes only. Do NOT drill until measurements are verified.

STAINLESS STEEL D9000 & D9000S

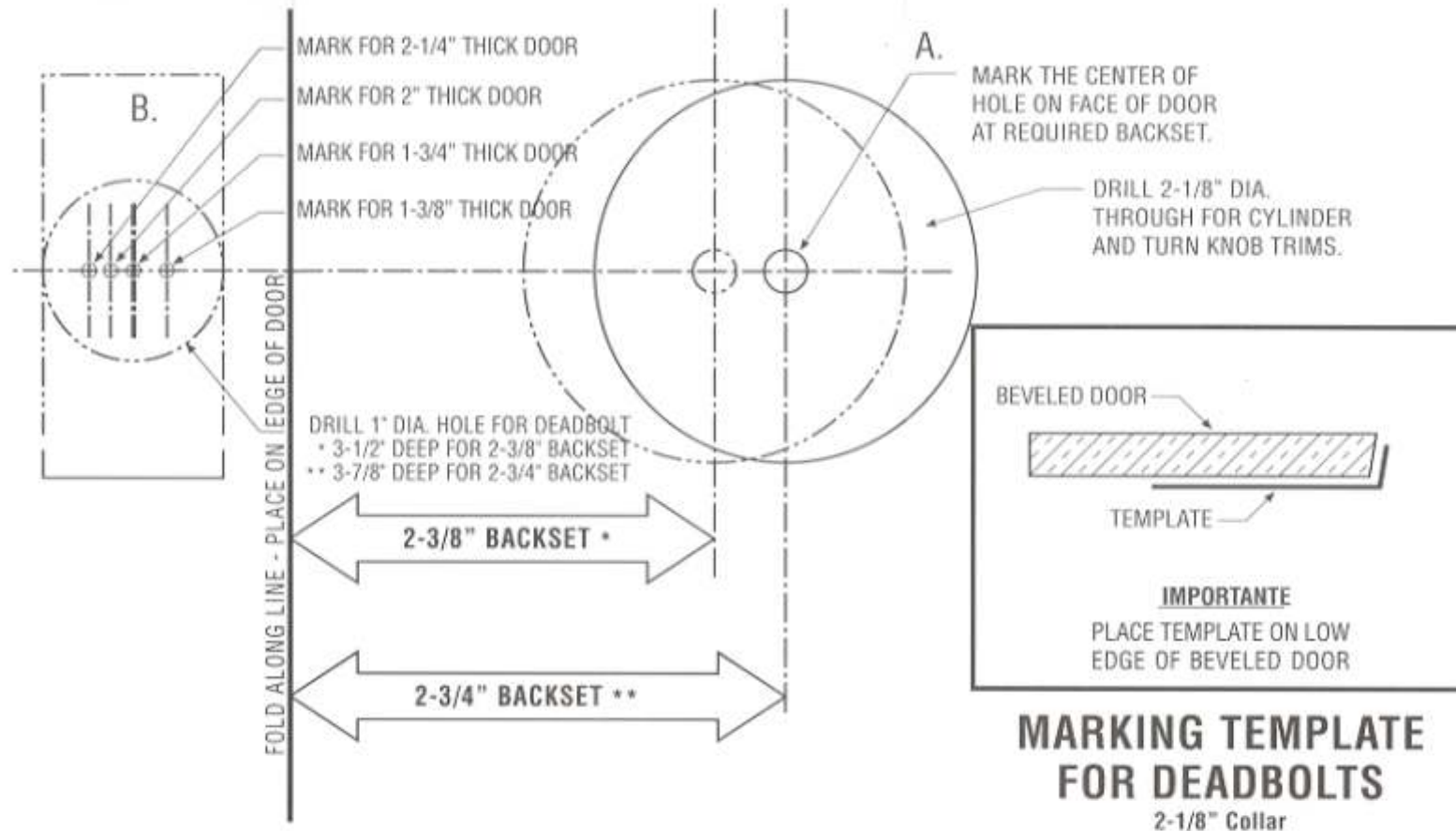

CHECK BACKSET BEFORE DRILLING!

BACKSET LOCATIONS ARE CALCULATED FOR LOW SIDE OF BEVELED DOORS.
 11/03

CAUTION: DOOR AND FRAME MANUFACTURERS

When door gasketing or silencers are used, proper allowances must be made for strike location to maintain a common centerline with lock and door so that the bolt will freely enter strike.

Deadbolt Installation for Single Cylinder

You have selected one of the latchset types illustrated in these instructions. The exploded views show, at a glance, how your latchset is assembled. Please follow the step-by-step installation instruction to ensure proper installation.

OMNIA

D9000 & D9000S

2-1/8" Bore Auxiliary Deadbolt Set

Exploded View Single Cylinder Deadbolt

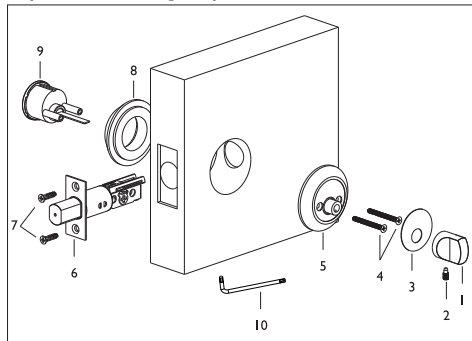

Parts Enclosed:

- 1 - 1 Turnpiece
- 2 - 1 Set Screw
- 3 - 1 Cover Plate
- 4 - 2 Breakaway Screws
- 5 - 1 Turnpiece Assembly
- 6 - Dead Bolt
- 7 - 2 Screws
- 8 - 1 Outside Cylinder Collar
- 9 - 1 Outside Cylinder With Studs
- 10 - Wrench

Note: See Strike Installation Section for strike parts listing.

Tools Needed:

Only Required for Doors Without Cutout

If your door is not pre-bored, see instructions for door preparation below:

- 1 - Pencil
- 2 - 2-1/8" diameter hole saw
- 3 - 1/2" or 1/4" wood chisel
- 4 - Drill and assorted bits: 1/8", 5/32" and 1"

Tools Needed:

Doors Prepared with 2-1/8" Cutout

- 1 - No.2 and No.3 Philips screwdrivers
- 2 - Measuring device
- 3 - Flathead Screwdriver

DOOR PREPARATION AND DEADBOLT INSTALLATION

1

To position template fold enclosed template on line and locate on door at desired height.

If you have a new door that is not already cut-out, please follow these instructions. (If your door is pre-bored please proceed to Single Cylinder & Double cylinder Deadbolt Installation - Step 1). If the door is beveled, place the folded edge on low side of bevel as shown in the illustration. Determine backset (2-3/8" or 2-3/4"). Mark the door for face and edge bores.

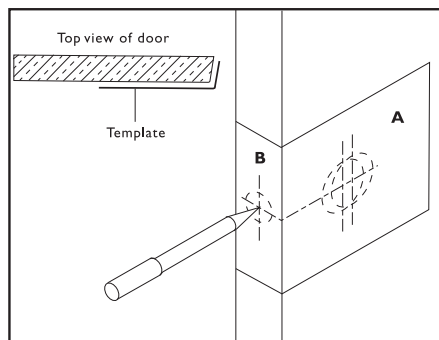

2

Drill the 2-1/8" diameter face bore (A) through the door and 1" diameter edge bore (B).

Caution: Re-check hole locations before drilling.

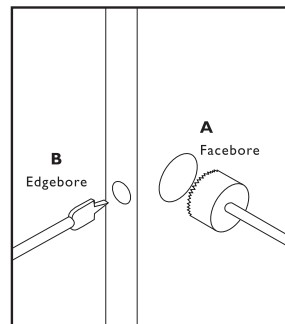

3

Insert deadbolt into edge of door while holding faceplate. Trace the outline of face plate onto the door edge. Mark screw hole centers and drill with a 1/8" drill.

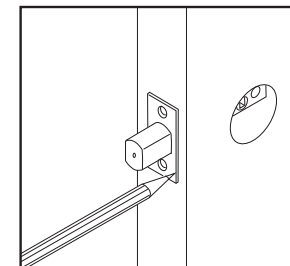

4

Chisel out the area marked for the faceplate to a depth of 5/32" or until faceplate is flush with door edge.

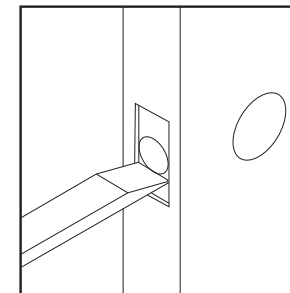

5

Install bolt in edge bore with cross hub down. Fasten bolt with two screws.

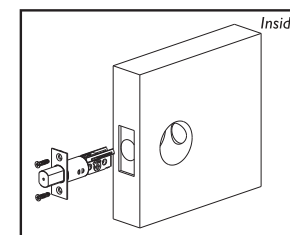

800.310.7960

www.OmniaIndustries.com

SINGLE CYLINDER ASSEMBLY

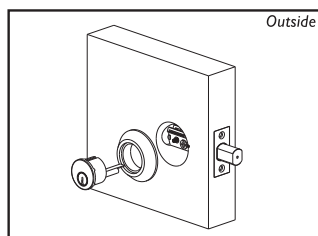

- 1** Insert flat blade screwdriver into deadbolt hub, and extended the bolt. Keeping the tailpiece in a vertical position, insert cylinder through collar and into deadbolt hub. Key must not be in cylinder during this procedure. Hold cylinder in place on the door.

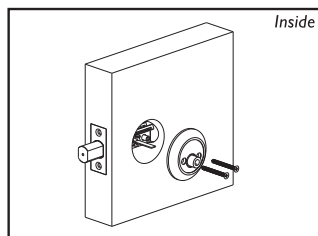

- 2** Place turnpiece assembly with hole on brass receiver facing the hinge side of the door. For 1- 3/8" Thick doors only, snap off breakaway screws. Install 2 breakaway screws.

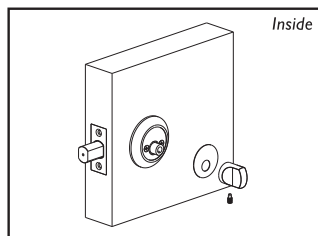

- 3** Retract the bolt to open position. Install coverplate and turnpiece as per picture and secure with set screw. Proceed now with strike installation.

DOUBLE CYLINDER ASSEMBLY

* Before proceeding see *Installing Deadbolt 1* and *2*.

Exploded View Double Cylinder Deadbolt

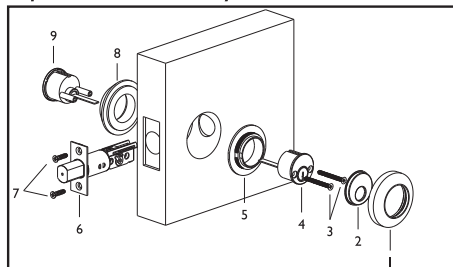

Parts Enclosed:

- | | |
|------------------------------|-------------------------------|
| 1 - 1 Inside Cylinder Collar | 6 - 1 DeadBolt |
| 2 - 1 Inside Cylinder Cap | 7 - 2 Screws |
| 3 - 2 Breakaway Screws | 8 - 1 Outside Cylinder Collar |
| 4 - 1 Inside Cylinder | 9 - 1 Outside Cylinder |
| 5 - 1 Inside Threaded Collar | |

Note: See Strike Installation Section for strike parts listing.

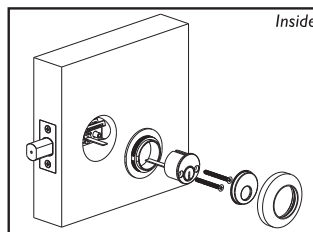

- 1** Insert flat blade screwdriver into deadbolt hub, and extend the bolt keeping the tailpiece in a vertical position. Insert cylinder through collar and into deadbolt hub. Key must not be in the cylinder during this procedure. Hold cylinder in place on the door.

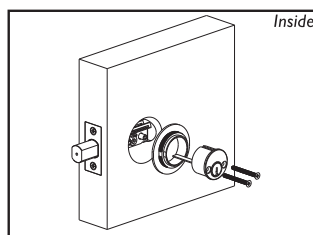

- 2** Align lug on threaded collar into slot on cylinder. With tailpiece in vertical position, install inside cylinder, keeping flat side of inside and outside tailpieces together. Install two breakaway screws through inside cylinder. For 1- 3/8" thick doors only, snap off breakaway screws.

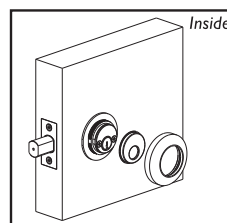

- 3** Install cylinder cap on inside cylinder, and then screw inside cylinder collar onto threaded collar. Proceed now with strike installation.

STRIKE INSTALLATION

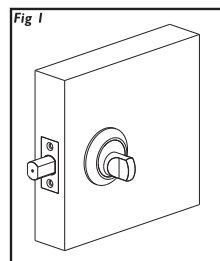

- 1** Close door and extend deadbolt several times against door frame. Strike centering indicator will leave a center mark on the door frame. (Fig.1)

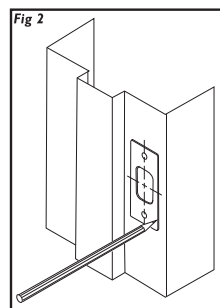

- 2** Position strike plate on center mark. Align and trace outside of strike and mounting screws onto the door frame. (Fig.2)

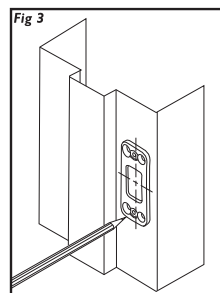

- 3** Using reinforcing strike as a template, mark locations for reinforcing screws. (Fig.3) Drill two 5/32" dia. pilot holes for the 3" long screws and two 1/8" diam. pilot holes for the # 8x3/4" screws. Mark drill points 5/16" above and below centering point. Bore two 1" dia. Holes 1-1/4" deep at these points. Chisel out holes for dust box. (Fig.4)

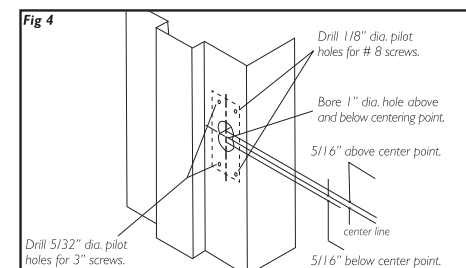

- Fig 4**
 Drill 1/8" dia. pilot holes for # 8 screws.
 Bore 1" dia. hole above and below centering point.
 5/16" above center point.
 center line
 5/16" below center point.
 Drill 5/32" dia. pilot holes for 3" screws.

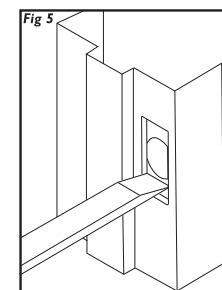

- 4** Mortise 7/32" deep or until the strike box, reinforcing strike and strike plate fits inside mortise and flush with the door frame. (Fig.5)

5 Install Strike as illustrated.

- 1 - Dust Box
- 2 - Reinforcing Strike
- 3 - #8x3/4" Combination Screws (2)
- 4 - 3" reinforcing Screws* (2)
- 5 - Strike plate
- 6 - 6. #8-32x1/4" Machine Screws (2)

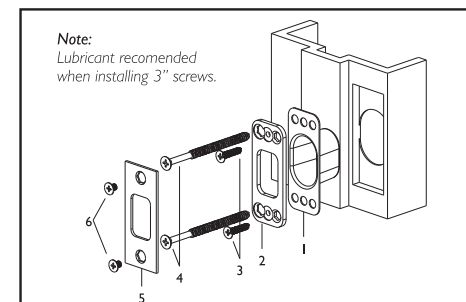

Note:
 Lubricant recommended when installing 3" screws.

Congratulations

Your installation is now complete!

We thank you for your purchase.