

KICKSPACE HEATERS MODELS 9112NT & 9114NT

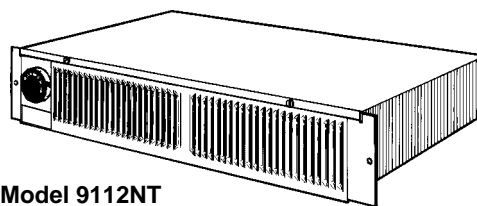

Model 9112NT

Low-profile design provides floor-level heat from out-of-the-way locations.

FEATURES

- Attractive white finish
- Vertical louvers – disperse heat evenly
- Front-mounted, snap action, bimetallic thermostat (Model 9112NT only)
- Heavy-duty, steel sheathed, plate-finned element
- Factory-wired for 240 VAC, 1500W
- Field-convertible to operate on 120 VAC, 750 or 1500W
- Mounts into standard kickspaces beneath cabinets, vanities, counters, stairways, etc.

ACCESSORIES (purchase separately)

- Model 86W Line-Voltage Thermostat
- Model 59W / 59V 60 Minute Timer
- Model 61W / 61V 15-Minute Timer
- Model 90 Built-in Thermostat Kit (Model 9114NT only)

SPECIFICATIONS

VOLTS	WATTS	AMPS	BTU/HR	SHIPPING WEIGHT
240	1500	6.2	5120	12 lbs.
120	750	6.2	2560	
208	1125	5.4	3840	
120	1500	12.5	5120	

BOLD ratings are factory-wired.

TYPICAL SPECIFICATION

The heater shall be NuTone Model 9112NT (Model 9114NT).

Unit shall have heavy-gauge steel housing and grille with white finish.

Heater will have heavy-duty, steel-sheathed, plate-finned element. Heater will have front-mounted thermostat (Model 9112NT only).

Heater to deliver 1500 watts of fan-forced heat from 240 VAC circuit. It must be convertible to operate on 120 VAC, full or half-wattage.

Heater shall be U.L. Listed.

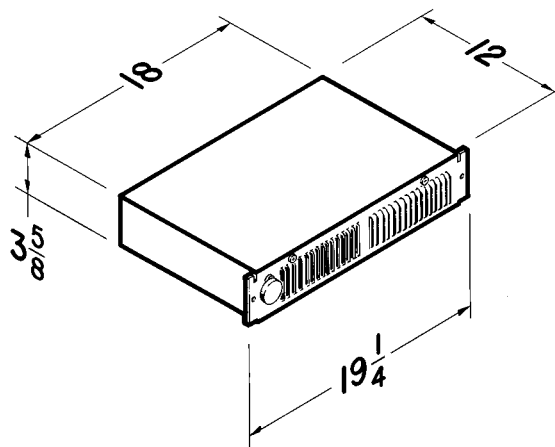

NuTone, Inc., Madison and Red Bank Roads, Cincinnati, OH 45227 (1-888-336-6151)

Product specifications subject to change without notice

REFERENCE	QTY.	REMARKS	Project
			Location
			Architect
			Engineer
			Contractor
			Submitted by
			Date