

DESCRIPTION

BLOWER:

- Plug-in, permanently lubricated motor - engineered for continuous operation
- Dynamically balanced centrifugal blower wheel for quiet, efficient performance
- Low RPM for quiet operation
- Resilient anti-vibration motor mounts

HOUSING:

- Rugged, 26 gauge, galvanized steel construction
- Polymeric, 4" duct connector with tapered sleeve and no metallic clatter
- 7-5/8" height allows for 2" x 8" (nominal) joist installations
- Sturdy, easy, four-point mounting directly to joist
- Includes unique spacer (patent pending) for mounting to engineered "I" joists
- Can be mounted in ceilings up to 7/12 pitch

GRILLE:

- Polymeric construction
- Innovative design - the result of extensive research with designers and consumers
- 100W incandescent lighting or equivalent energy efficient CFL (bulb not included)
- 4W night light (bulb not included)
- Durable steel reflector with white enamel finish

CONTROLS (Purchase separately):

- Refer to NuTone's catalog for a complete line of accessories to effectively adapt these fans to your construction requirements.

U.L. Listed for use over bathtubs and showers when connected to a GFCI protected branch circuit (ceiling mount only).

U.L. Listed for use in insulated ceilings (TYPE I.C.)

3-Year Warranty



INSTALLATION

Complete installation instructions are included with each Fan / Light / Night Light.

Model QTN80L Fan/Light/Night Light

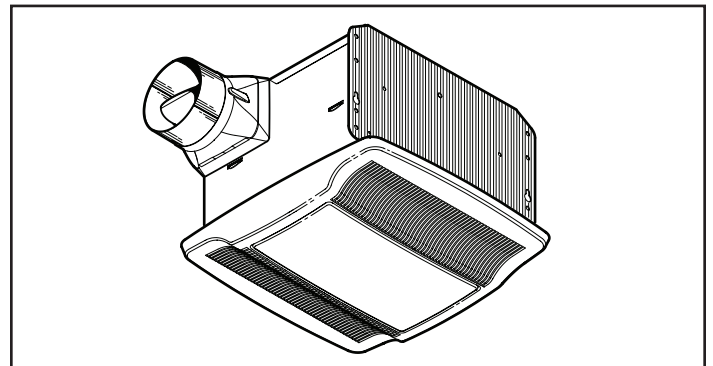

ARCHITECT'S SPECIFICATION

- Ceiling Ventilator shall be NuTone Model QTN80L.
- Ceiling Ventilator shall have corrosion resistant galvanized steel housing with four-point mounting capability. It shall be ducted to a roof or wall cap using 4" round ductwork.
- Blower assembly shall be removable, have a centrifugal-type blower wheel and a permanently lubricated motor designed for continuous operation and mounted with resilient anti-vibration mounts.
- Non-metallic damper/duct connector shall be included.
- Lamp shall be 100W incandescent with separate 4W night light.
- Air delivery shall be no less than 80 CFM and sound level no greater than 0.8 Sones. All air and sound ratings shall be certified by HVI.
- Ceiling Ventilator shall be U.L. Listed for use in insulated ceilings (Type I.C.) and for use over bathtubs and showers when connected to a GFCI protected branch circuit.

Broan-NuTone LLC Hartford, Wisconsin www.nutone.com 888-336-3948

REFERENCE	QTY.	REMARKS	Project
			Location
			Architect
			Engineer
			Contractor
			Submitted by Date

PERFORMANCE RATINGS

MODEL QTN80L FAN / LIGHT / NIGHT LIGHT

HVI PERFORMANCE

Model	Static Pressure (Ps)	CFM	Sones
QTN80L	0.10	80	0.8
	0.25	66	



HVI-2100 CERTIFIED RATINGS comply with new testing technologies and procedures prescribed by the Home Ventilating Institute, for off-the-shelf products, as they are available to consumers. Product performance is rated at 0.1 in. static pressure, based on tests conducted in a state-of-the-art test laboratory. Sones are a measure of humanly-perceived loudness, based on laboratory measurements.

AIR FLOW PERFORMANCE

MODEL QTN80L

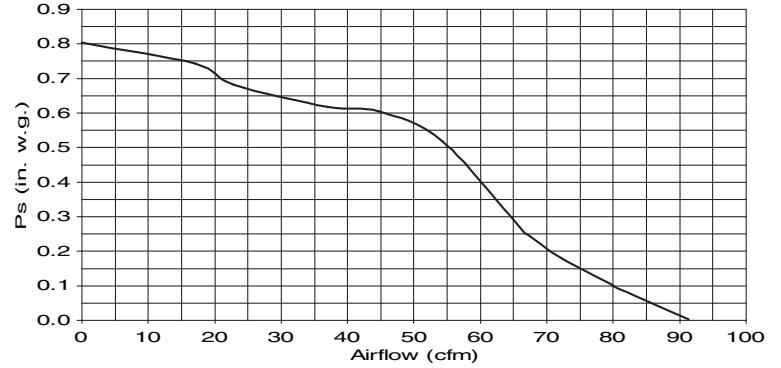

AMPS

Model	Amps *
QTN80L	1.6

* Total connected load

WEIGHT

Model	Shipping Weight
QTN80L	13.8 lbs.

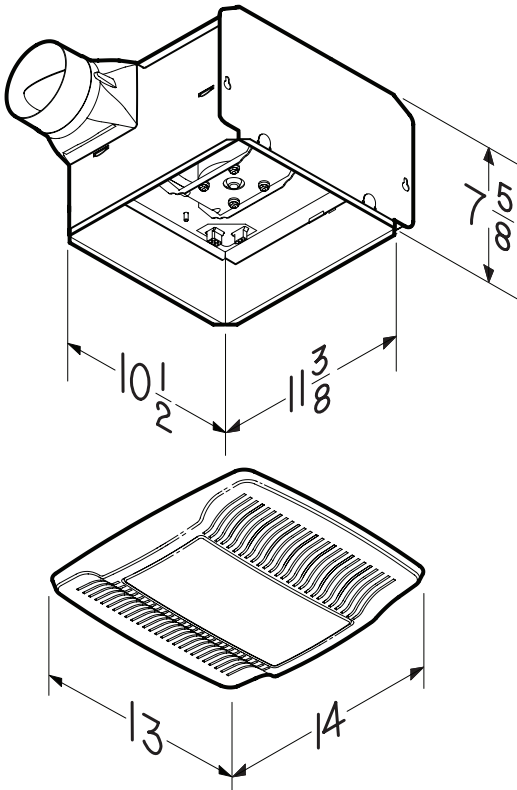

NuTone®