

Model NR50 Series Residential Tankless Water Heater Specification Sheet

- **Standard Input** - gas consumption ranges from 19,000 BTUh (NG) and 20,000 BTUh (LPG) up to 120,000 BTUh
- **Capacity Range** - flow rates from 0.5 gpm up to 5.0 gpm
- **Compact Design** - ANSI Z21.10.3/CSA 4.3 certified design that can be installed outdoors
- **Durable Steel Casing with Polyester Coating**
- **No Venting Required** - Outdoor (-OD) model does not require any additional stainless steel venting
- **Direct Electronic Ignition**
- **Energy Factor** - 0.82 for NG and LP
- **Thermal Efficiency** - 83% efficient for use with natural gas or propane
- **Temperature Controls** - includes 120°F (default), 130°F, 135°F, or 140°F standard temperature settings*
- **Safety Devices** - Flame Sensor, Overheat Prevention Device, Lightning Protection Device
- **Additional Features** - Temperature Lockout, Flow Meter Alarm, Optional Freeze Protection
- **12-Year** Limited Heat Exchanger Warranty for Residential Use**
- **5-Year Limited Parts Warranty**
- **1-Year Reasonable Labor**
- **Approvals** - CSA (US only), UPC***, NSF, Low NOx Approved By SCAQMD (Rule 1146.2), Suitable for Installation in a Manufactured (Mobile) Home****



NR50-OD



This model is eligible for the Federal tax credit of up to 10% of the water heater and installation costs (up to \$300) when installed in a residence between 1/1/2011 through 12/31/2011

Model

NR50 - OD

Accessories

- Remote Controller (#RC-7649M)
- Remote Controller Cord (#RC-CORD10)
- Pipe Cover (#PC-1S)
- Isolator Valves (#IK-WV-7)
- Recess Box for OD Model (#RB-500)
- Freeze Protection Kit (#SKG7772)



* Optional remote thermostat can precisely adjust the output temperature from 100°F to 160°F in 5°F intervals

** 3-Year Heat Exchanger warranty if supplied with pre-heated or circulated water, refer to the Noritz Limited Warranty for complete coverage details

*** This product complies with California AB 1953 Low Lead Law

**** Manufactured (Mobile) Home approval is valid for **OD** models only

Dimensions

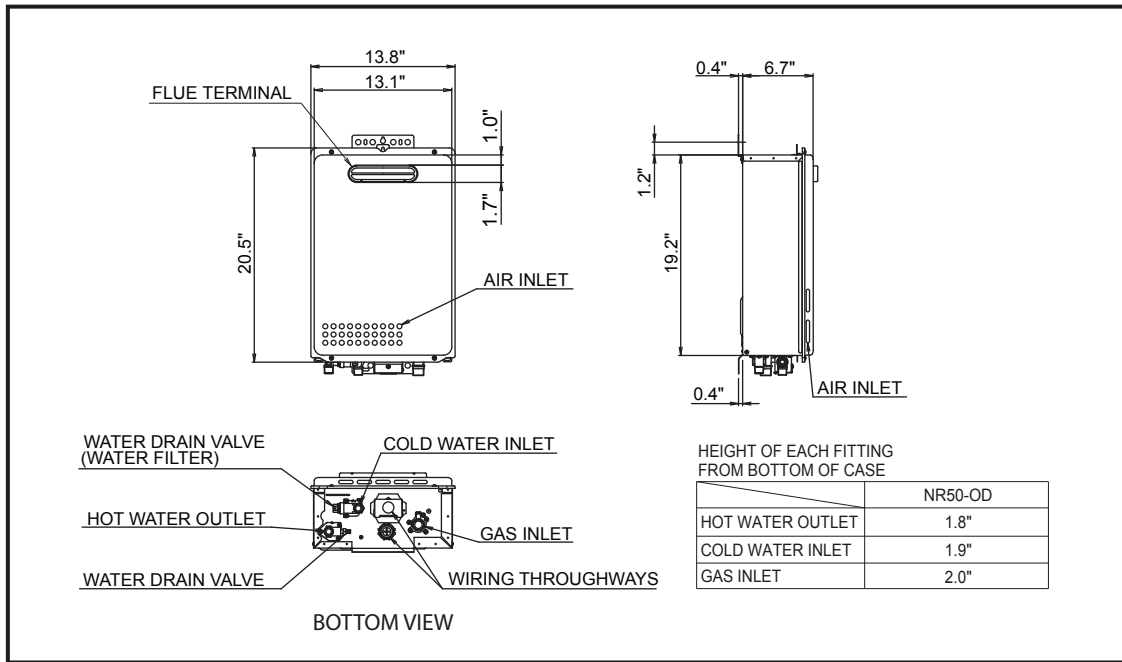

Flow Rates

Temperature Rise (°F)	30	40	45	50	60	70	80	90	100
Flow Rate (GPM)	5.0	5.0	4.2	3.9	3.3	2.8	2.5	2.2	2.0

Pressure Loss

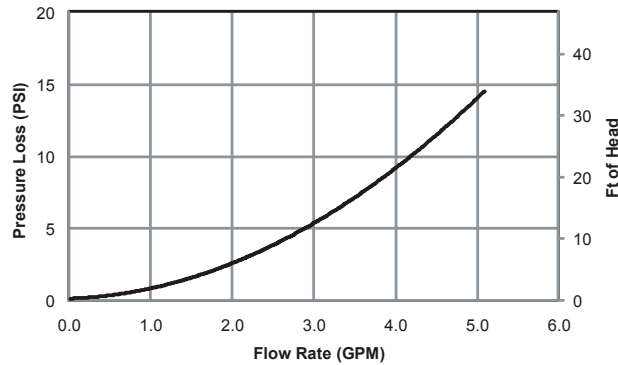

Specifications

Model Name		NR50-OD
Weight		33 (pounds)
Water Holding Capacity		0.2 Gallon
Connection Sizes	Water Inlet	3/4"
	Hot Water Outlet	3/4"
	Gas Inlet	1/2"
Power	Supply	120VAC (60Hz), less than 2 amperes
	Consumption	NG: 36W LP: 39W Freeze Prevention (optional) 141W
Temperature Settings		100-150°F (In 5°F intervals), 160°F (12 Options)
Default Temperature Options		120, 130, 135, 140°F (Default is 120°F)