

NOTES:

- (N1) 1. FIT / FORM / FUNCTION SHALL FOLLOW PS-E.008.

BILL OF MATERIAL (CURRENT LEVEL)

ITEM	PT/ASSY	DESCRIPTION	TYPE	QTY.
1	50413	BODY, PLASTIC (502)	PART	1
2	50414	NUT PLASTIC	PART	1
3	50662	HANDLE WITH TAPERED HOLE	PART	1
4	50415	PLASTIC ARM	PART	1
5	92207	SCRW 10-24 X 1/2 PAN HD S.STL.	PART	1

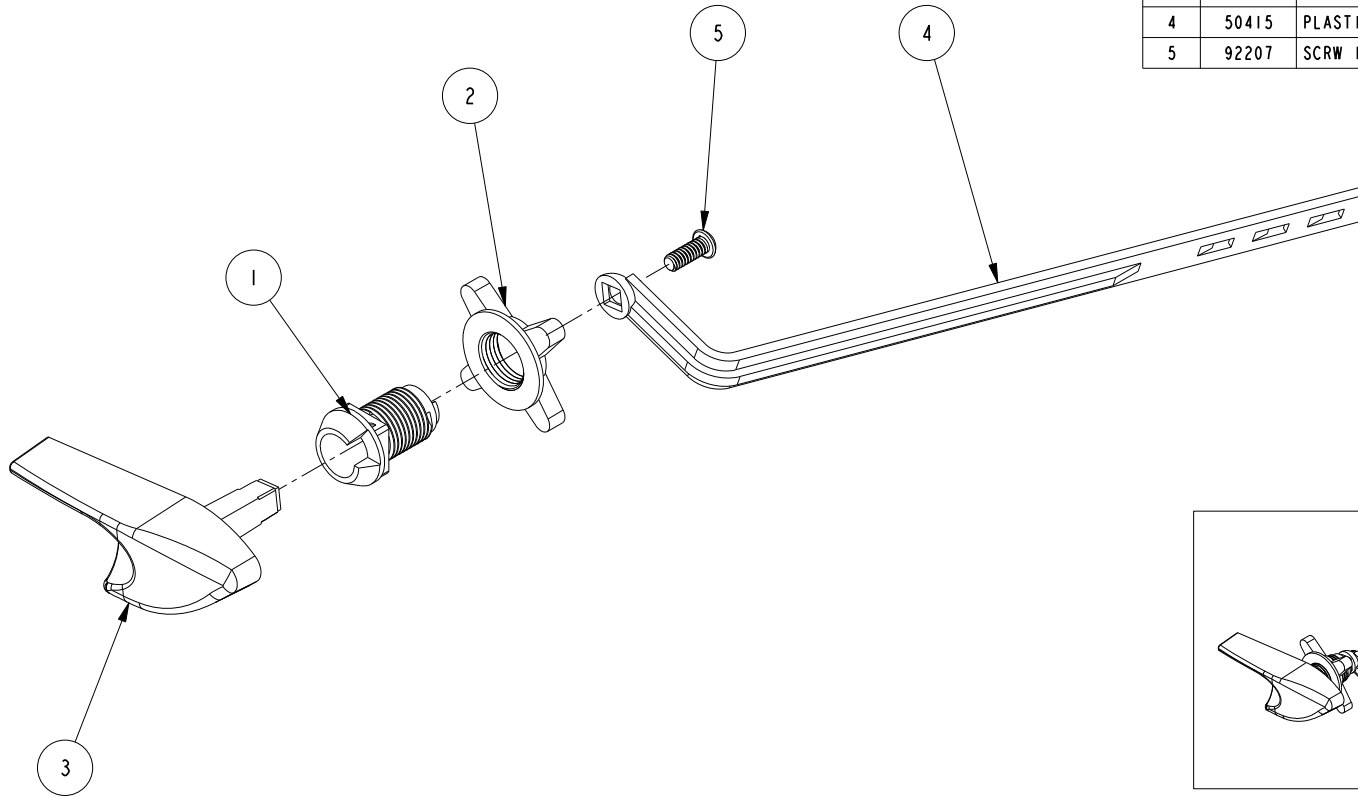

TESTING	-	-	-
ASSEMBLY	-	-	-
PLATING	-	-	-
POLISHING	-	NEXT ASSY	USED ON
MACHINING	-	APPLICATION	
TOOLING FIXTURE #	REMOVE ALL BURRS AND SHARP EDGES		

UNITS ARE: INCHES [MM]
 TOLERANCES ARE:
 FRACTIONS DECIMALS ANGLES
 $\pm 1/16"$.X $\pm .1$ [2.5] $\pm 1^\circ$
 .XX $\pm .06$ [1.5]
 (X.XXX) DENOTES CRITICAL DIMS.
 ALL THREADS ARE CRITICAL

BRASSTECH 2001 CARNEGIE AVE.
 INCORPORATED SANTA ANA, CA 92705
 (949) 417-5207

TANK LEVER

-	B	EN-3302	04/21/17	J.M.
-	A	-	-	-
-	-	RELEASED	-	-
ZONE	REV	DESCRIPTION	DATE	APPROVED

COPYRIGHT 2005 BRASSTECH, INC.
 THESE DRAWINGS AND THE DESIGNS
 DEPICTED HEREIN ARE THE PROPRIETARY
 PROPERTY OF BRASSTECH. ANY USE
 OR REPRODUCTION IS SUBJECT TO
 THE EXPRESS APPROVAL OF BRASSTECH.
 UNAUTHORIZED USE IS STRICTLY
 PROHIBITED. ALL RIGHTS RESERVED.

DRAWN R.S. 04/21/17
 CHECKED J.M. 04/21/17
 APPROVED J.M. 04/21/17

DWG NO. **502** REV B
 SCALE .500 REF. - SHEET 1 OF 2

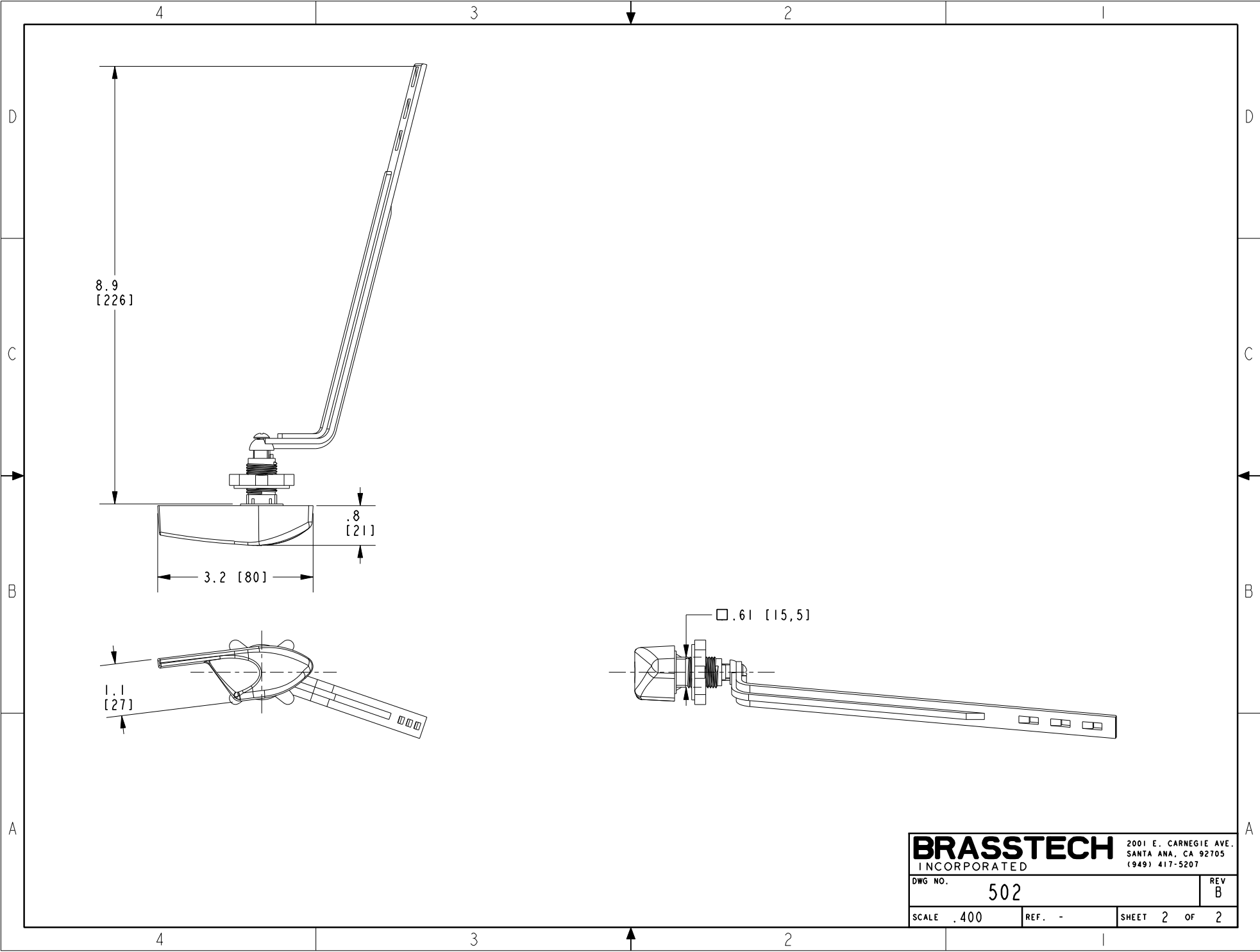

BRASSTECH		2001 E. CARNEGIE AVE.	
INCORPORATED		SANTA ANA, CA 92705	
		(949) 417-5207	
DWG NO.	502	REV	B
SCALE	.400	REF.	-
		SHEET	2 OF 2