

4

3

2

1

BILL OF MATERIAL (CURRENT LEVEL)

ITEM	PT/ASSY	DESCRIPTION	TYPE	QTY.
1	200	SHOWER ARM 6" BRASS	PART	1
2	206	SHOWER ARM FLANGE	PART	1
3	212	SHOWER HEAD	ASSEMBLY	1
4	1-110	BLANK BUTTON W/ADHESIVE	ASSEMBLY	1
5	2-225	BP COVER PLATE FOR SHOWER	ASSEMBLY	1
6	3-280	HANDLE/ESCUTCHEON ASM	ASSEMBLY	1

D

D

C

C

B

B

A

A

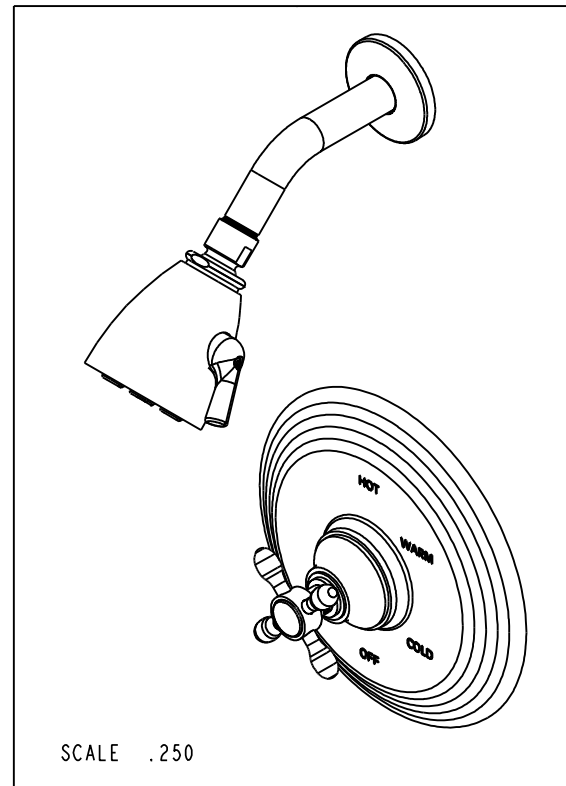
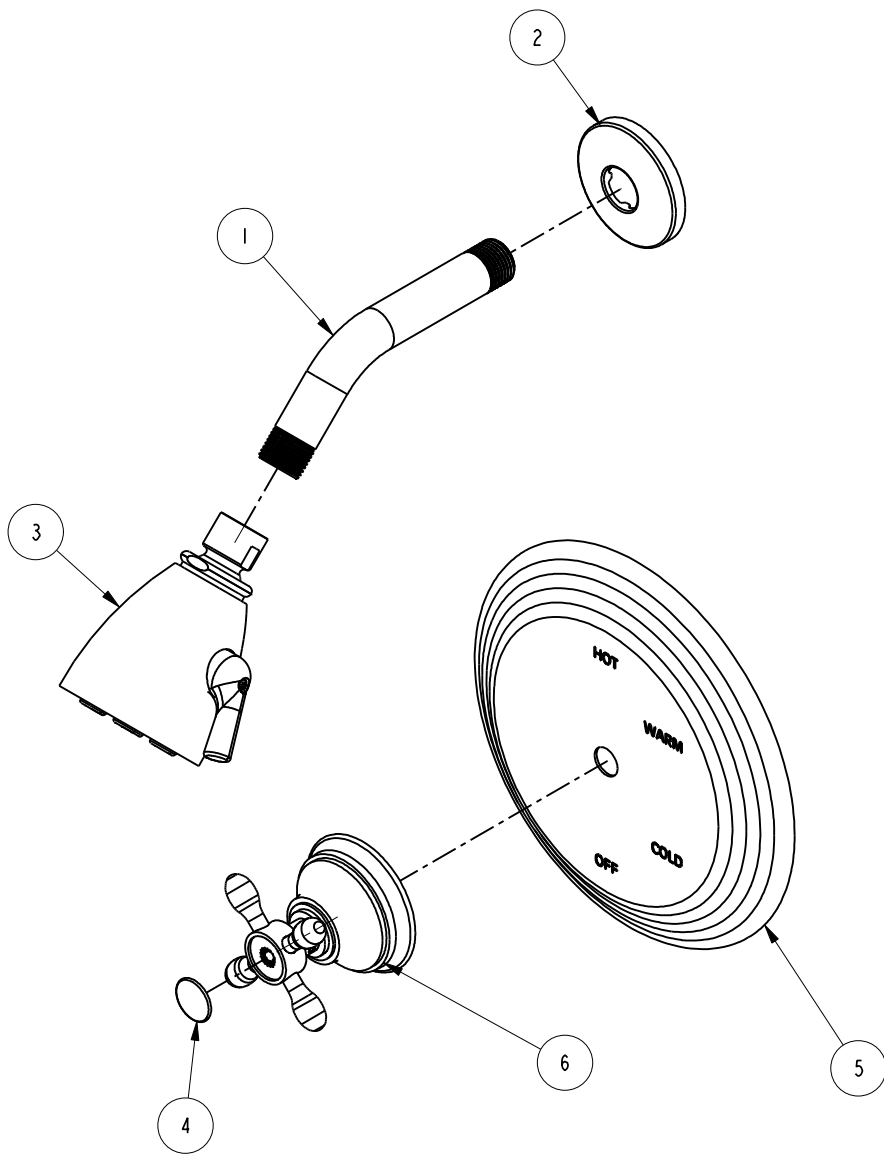

COPYRIGHT 2005 BRASSTECH, INC. THESE DRAWINGS AND THE DESIGNS DEPICTED HEREIN ARE THE PROPRIETARY PROPERTY OF BRASSTECH. ANY USE OR REPRODUCTION IS SUBJECT TO THE EXPRESS APPROVAL OF BRASSTECH. UNAUTHORIZED USE IS STRICTLY PROHIBITED. ALL RIGHTS RESERVED.

BRASSTECH
 INCORPORATED
 2001 E. CARNEGIE AVE.
 SANTA ANA, CA 92705
 (949) 417-5207

TRIM KIT - 3-1644BP

ASSY. NO.	3-1644BP		B	EN-1745	08/22/11
SCALE .300	REF. -	SHEET 1 OF 3	A	EN-1183	03/23/09
			-	EO-0299	03/04/04
			REV	REV DESC	DATE

4

3

2

1

SPECIFICATION DWG

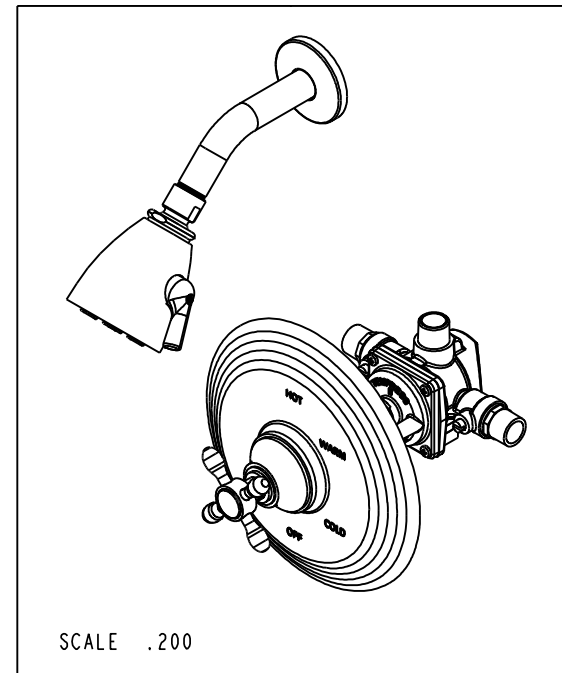
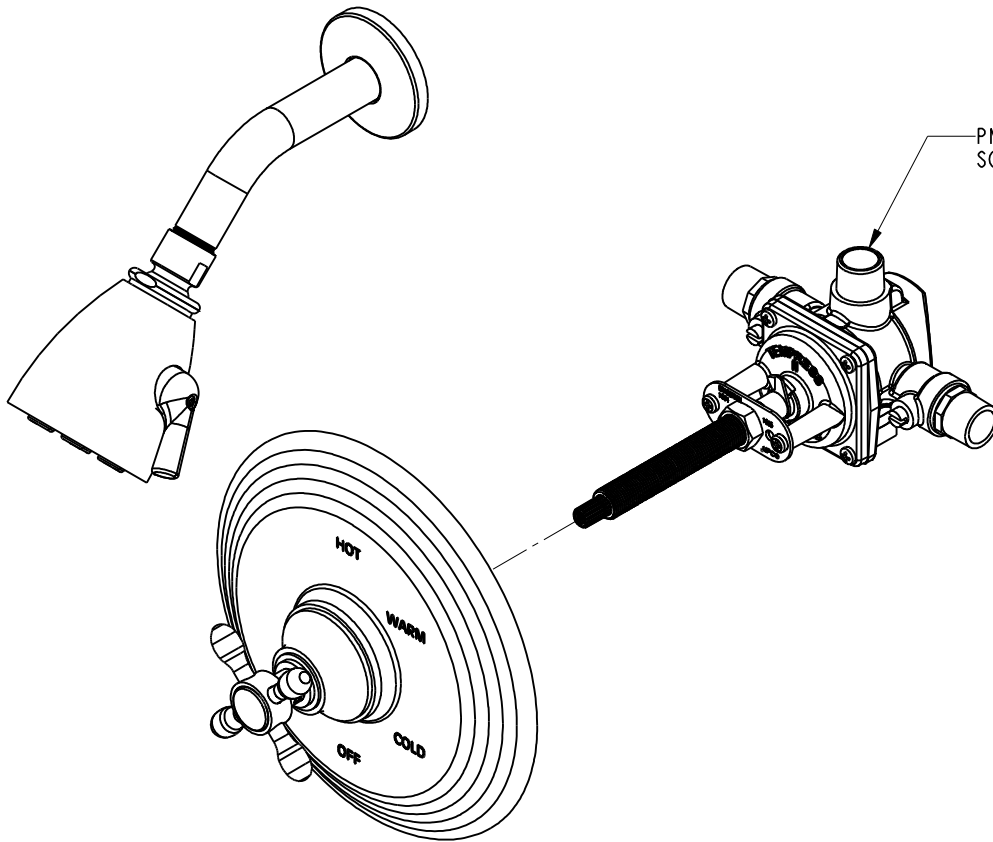

DIMENSIONS ARE IN INCHES AND AN APPROXIMATION OF A TYPICAL INSTALLATION

COPYRIGHT 2005 BRASSTECH, INC. THESE DRAWINGS AND THE DESIGNS DEPICTED HEREIN ARE THE PROPRIETARY PROPERTY OF BRASSTECH. ANY USE OR REPRODUCTION IS SUBJECT TO THE EXPRESS APPROVAL OF BRASSTECH. UNAUTHORIZED USE IS STRICTLY PROHIBITED. ALL RIGHTS RESERVED.

BRASSTECH		2001 E. CARNEGIE AVE. SANTA ANA, CA 92705 (949) 417-5207	
INCORPORATED			
DWG NO.	3-1644BP	REV	B
SCALE	.300	REF.	-
		SHEET	2 OF 3

NOTES:

- 1. CUT STEM TO DIMENSION SHOWN.
- 2. CUT ALL-THREAD 3/4" SHORTER THAN STEM.

SPECIFICATION DWG

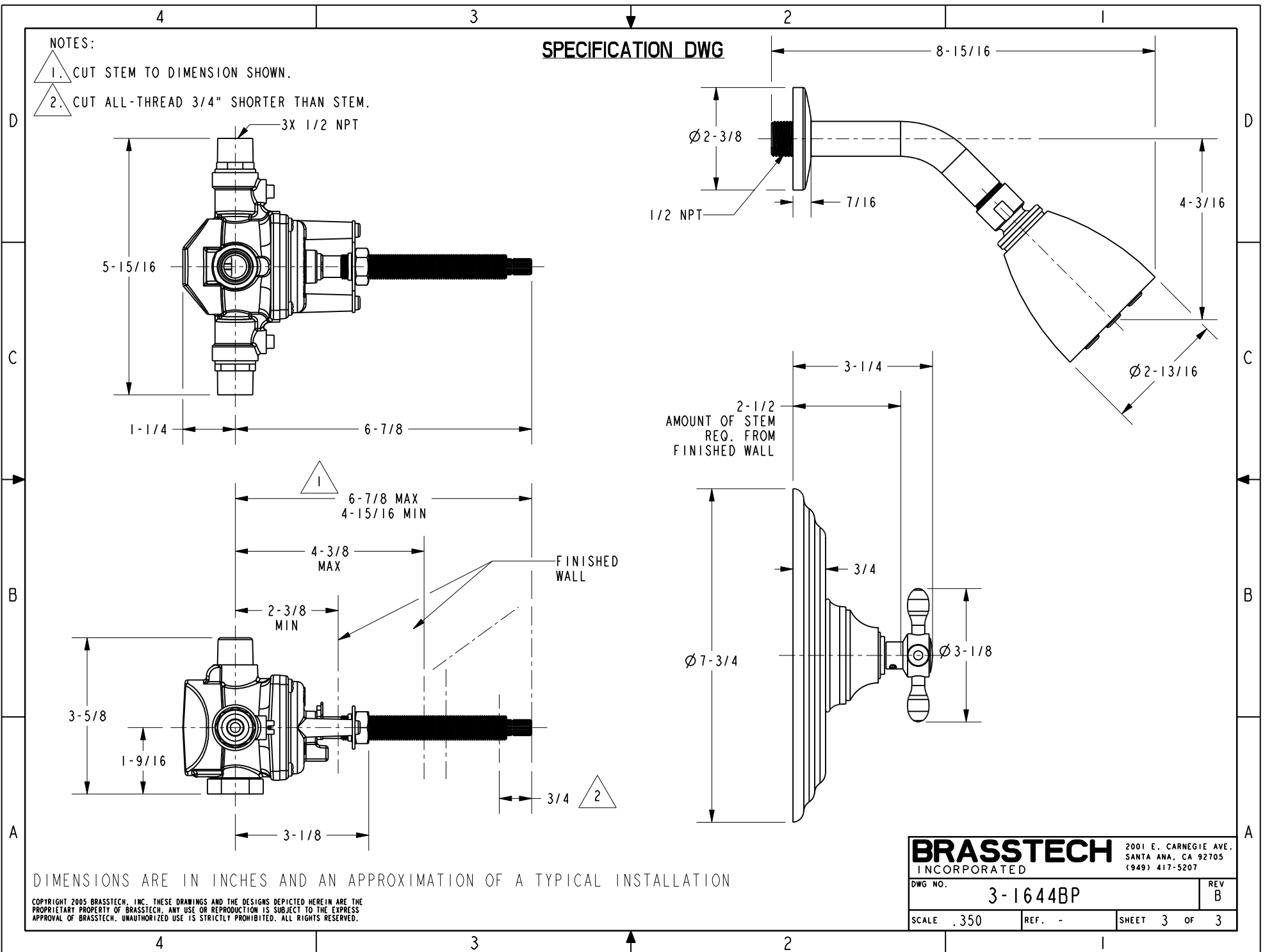

DIMENSIONS ARE IN INCHES AND AN APPROXIMATION OF A TYPICAL INSTALLATION

COPYRIGHT 2005 BRASSTECH, INC. THESE DRAWINGS AND THE DESIGNS DEPICTED HEREIN ARE THE PROPRIETARY PROPERTY OF BRASSTECH. ANY USE OR REPRODUCTION IS SUBJECT TO THE EXPRESS APPROVAL OF BRASSTECH. UNAUTHORIZED USE IS STRICTLY PROHIBITED. ALL RIGHTS RESERVED.

BRASSTECH		2001 E. CARNEGIE AVE. SANTA ANA, CA 92705 (949) 417-5207	
DWG NO.	3-1644BP	REV	B
SCALE	.350	REF.	-
		SHEET	3 OF 3