

NOTES:

1. TO INSPECT ASSEMBLY, FOLLOW FIRST ARTICLE AND IN PROCESS INSPECTION SHEET.

BILL OF MATERIAL (CURRENT LEVEL)

ITEM	PT/ASSY	DESCRIPTION	TYPE	QTY.
1	3-633	W/S SPOUT ASM	ASSEMBLY	1
2	3-646	LEVER HANDLE W/ESC.	ASSEMBLY	2
3	1-676	W/S VALVE INSTALLATION	ASSEMBLY	1
4	330	DRAIN, PUSH DOWN, W/ OVERFLOW	ASSEMBLY	1

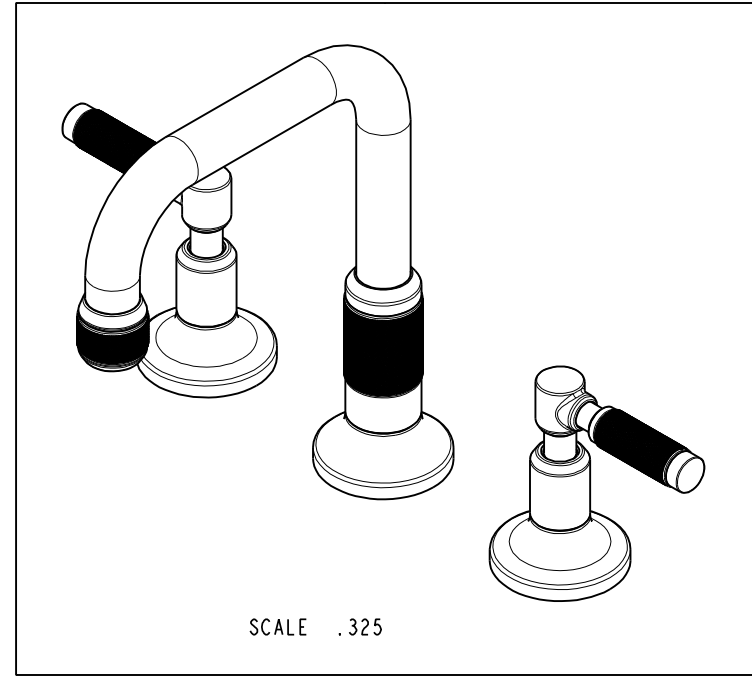
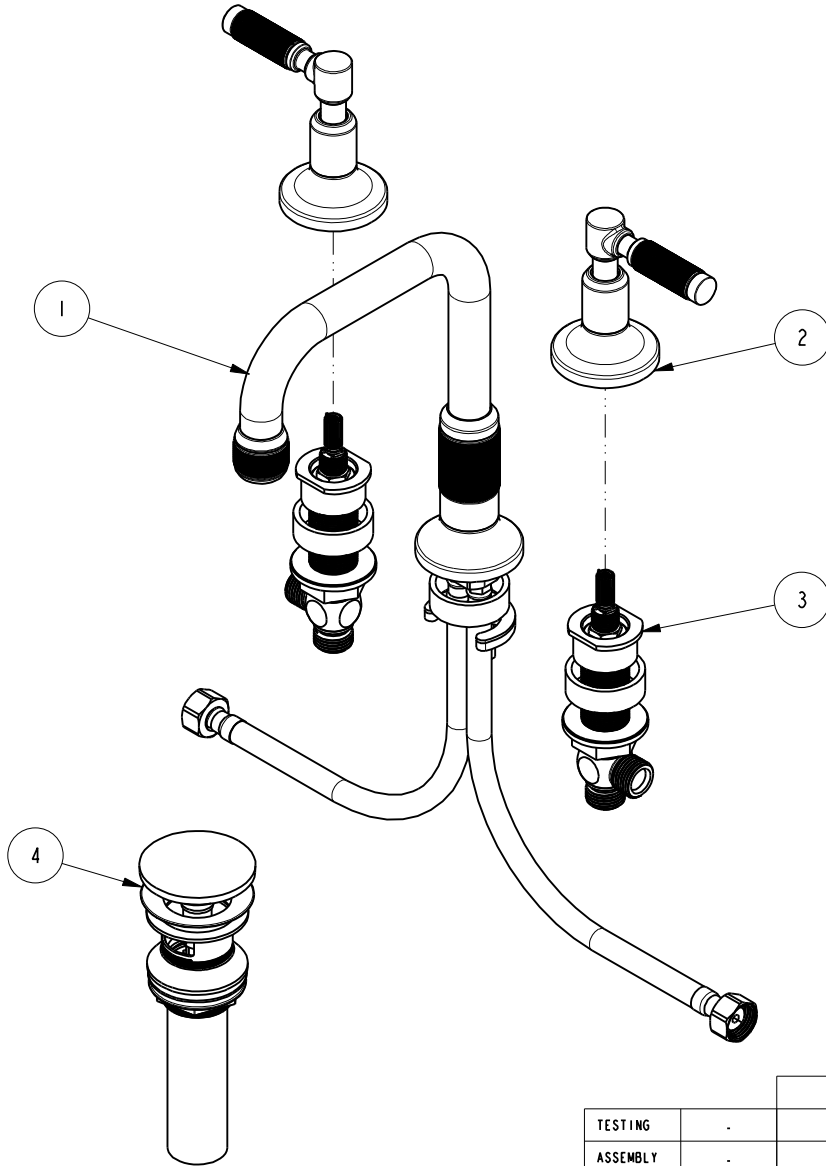

ZONE	REV	DESCRIPTION	DATE	APPROVED
-	B	EN-4300m	11/09/20	R.S.
-	A	EN-3869	05/15/19	J.M.
-	-	EN-3478	01/16/19	J.M.

COPYRIGHT 2005 BRASSTECH, INC. THESE DRAWINGS AND THE DESIGNS DEPICTED HEREIN ARE THE PROPRIETARY PROPERTY OF BRASSTECH. ANY USE OR REPRODUCTION IS SUBJECT TO THE EXPRESS APPROVAL OF BRASSTECH. UNAUTHORIZED USE IS STRICTLY PROHIBITED. ALL RIGHTS RESERVED.

TESTING	-	-	-
ASSEMBLY	-	-	-
PLATING	-	-	-
POLISHING	-	NEXT ASSY	USED ON
MACHINING	-	APPLICATION	
TOOLING FIXTURE #	REMOVE ALL BURRS AND SHARP EDGES		

UNITS ARE: INCHES [MM]
TOLERANCES ARE:
FRACTIONS DECIMALS ANGLES
±1/16" .X ±.1 [2,5] ±1°
.XX ±.06 [1,5]

(X.XXX) DENOTES CRITICAL DIMS.
ALL THREADS ARE CRITICAL

DRAWN	JINSON	11/09/20
CHECKED	R.S.	11/09/20
APPROVED	R.S.	11/09/20

BRASSTECH 2001 CARNEGIE AVE.
INCORPORATED SANTA ANA, CA 92705
(949) 417-5207

WIDESPREAD FAUCET

DWG NO.	3250	REV	B
SCALE	.250	REF.	-
SHEET	1	OF	2

